

Minimum Standards of Entrances to State Highways

CHAPTER 71.

24 VAC 30-71-10. Definitions.

The following words and terms when used in this chapter shall have the following meanings unless the content clearly indicates otherwise:

“Accessible route” means a continuous unobstructed, stable, firm and slip-resistant path connecting all accessible elements of a facility (may include parking access aisles, curb ramps, crosswalks at vehicular ways, walks, ramps and lifts) that can be approached, entered and used by persons with mobility impairments. An accessible route shall, to the maximum extent feasible, coincide with the route for the general public and shall be a minimum of three feet (0.9 meter) wide.

“Board” means the Commonwealth Transportation Board, Commonwealth of Virginia.

“Central Office” means the office in downtown Richmond that contains the administrative functions, including pre-construction activities, and executes command responsibility and control over all Virginia Department of Transportation activities.

“Clear Zone” means the ~~[unobstructed, relatively flat area provided beyond the edge of the traveled way for the recovery of errant vehicles~~ total roadside border area, starting at the edge of the traveled way, that is wide enough to allow an errant driver to stop or regain control of a vehicle. ~~The width of the clear zone is influenced by the type of facility, traffic volume, speed, horizontal alignment and embankment and is detailed in the department's Road Design Manual, English (revised October 1996) or metric (revised September 1996) or metric measurement versions (effective July 1998).~~ This area might consist of a shoulder, a recoverable slope, a non-

Minimum Standards of Entrances to State Highways

recoverable slope, and a traversable slope with a clear run-out area at its toe, or a combination of these. (See Manual on Uniform Traffic Control Devices, Millennium (2000) edition, effective January 17, 2001).]

“Commercial Entrance” means an entrance serving all entities other than an individual private residence. (See definition for “private entrance.”)

“Commissioner” means the Commonwealth Transportation Commissioner, who is also Vice-Chairman of the Commonwealth Transportation Board.

“Commonwealth” means the Commonwealth of Virginia.

“Crossover” or “Median Opening” means ~~[a state-maintained]~~ [an] area located between opposing traffic, usually paved, to provide for crossing, left turn or U-turn maneuvers, on four- or more lane divided highways.

“Department” means the Virginia Department of Transportation (VDOT).

“Design Speed” means the maximum safe speed that can be maintained over a specified section of highway when conditions are so favorable that the design features of the highway govern, as defined in the American Association of State Highway and Transportation Officials’ [(AASHTO’s)] [1994 2001] edition of A Policy on Geometric Design of Highways and Streets.

“District office” means the office in each of the nine construction districts located throughout the state that implements the construction and maintenance operations of the Virginia Department of Transportation.

“Engineer” means the engineer representing the Virginia Department of Transportation.

Minimum Standards of Entrances to State Highways

[“Functional Intersection Areas” means the physical area of an at grade intersection plus the boundary of the longitudinal limits of the auxiliary lanes (left and right turn lanes) of all the approaches of the intersection. The functional lengths include maneuver distance plus any required storage lengths of all turning bays.]

“Operating Speed” means the highest overall speed at which a driver can travel on a given highway under favorable weather conditions and under prevailing traffic conditions without at any time exceeding the safe speed as determined by the design speed on a section-by-section basis, as defined in the American Association of State Highway and Transportation Officials’ [(AASHTO’s)] [1994 2001] edition of A Policy on Geometric Design of Highways and Streets.

“Private Entrance” means an entrance ~~servicing an individual~~ that serves up to two private residences and used for the exclusive benefit of the occupant.

“Private Subdivision Road or Street” means a road or street that serves more than ~~one~~ two individual ~~property~~ properties, is privately owned and maintained and requires a commercial entrance permit.

“Right-of-Way” means that property within the entire area of every way or place of whatever nature within the system of state highways under the ownership, control or jurisdiction of the board, ~~which that~~ that is open or ~~which that~~ that is to be open within the future for the use of the public for purposes of travel in the Commonwealth. The area set out above includes not only the traveled portion but the entire area inside and outside the traveled portion, from boundary line to boundary line, and also parking and recreation areas ~~which that~~ that are under the ownership, control or jurisdiction of the board.

Minimum Standards of Entrances to State Highways

“Sight Distance” means, for crossovers and commercial entrances, ~~[(intersection sight distance),]~~ the ~~[unobstructed]~~ distance measured ~~[between the height of the driver’s eye (3.5 feet) (1.07 meter) and the height of a 4.25 foot (1.30 meter) object without horizontal or vertical obstruction to the line of sight from the driver to an object. For sight distance calculations, height of the driver’s eye is considered to be 3.5 feet (1.08 meter) and the height of object is also considered to be 3.5 feet (1.08 meter) above the roadway.]~~

“System of State Highways” means all highways and roads under the ownership, control, or jurisdiction of the board including, but not limited to, the primary, secondary, and interstate systems.

24 VAC 30-71-20. Procedure for obtaining permits.

All applications for permits shall be obtained from and submitted through the office of the resident engineer for the county in which the work is to be performed. The applicant shall submit plans and application form for all proposed installations in sufficient time to permit the department to review them and make any necessary studies and changes. The plans shall include detailed and complete information concerning the location of the work, the type pavement, the roadway geometrics and other facts about the highway.

The resident engineers are authorized to issue private entrance permits. District administrators or their designees are authorized to issue commercial entrance permits (except outdoor theaters), permits for individual logging roads, permits for median crossovers, and permits for private entrances.

Minimum Standards of Entrances to State Highways

Any waiver of the required sight distance may only be granted by the chief engineer [for program development] or the [~~assistant commissioner for operations~~ state location & design engineer] after a traffic engineering investigation has been conducted. However, a significant (i) increase of traffic in and out of the entrance, (ii) change in character of the traffic or peak hour volume, (iii) operational safety problem may require upgrading or reconstruction, or both, of the entrance or closing the entrance. This language is not intended to be exclusive.

Permits cover not only the actual performance of work as approved, but also cover the subsequent maintenance, adjustment or removal of work. All permits shall be issued to the owners of the facilities or, in cases where continuing bonds are required, permits may be issued jointly to the owner and his contractor (as agent). The central office shall maintain permanent records of all permits issued.

24 VAC 30-71-30. Appeal procedure.

Permit applications shall be processed in a timely fashion. Applicants shall be notified in writing of the action taken on applications. If the permit is granted, issuance of the permit shall satisfy that requirement. If the permit is denied, notification of denial shall be made by certified mail, return receipt requested.

If the resident engineer either denies a permit sought or imposes conditions upon the issuance of a permit with which the applicant disagrees, an appeal may be made to the district administrator.

The district administrator, chief engineer [for program development] or [~~assistant commissioner for~~ chief engineer of] operations, as the case may be, is authorized to consider and

Minimum Standards of Entrances to State Highways

render a ruling on unresolved differences of opinion between the applicant and the resident engineer concerning the interpretation and application of these requirements.

To utilize the appeal process, the applicant shall provide the district administrator with a written request for review, setting forth a brief description of the unresolved issues within 30 days of receipt of the denial. The district administrator shall advise the applicant in writing within 60 days of the receipt of the appeal of his decision.

24 VAC 30-71-40. Drive-in theaters.

Certain conditions as set forth in § 33.1-12(15) of the Code of Virginia shall first be met in order to construct entrances to drive-in theaters.

24 VAC 30-71-50. Entrance design.

All entrance design and construction shall comply with the department's design and construction criteria set forth in the documents incorporated by reference in 24 VAC 30-71-170.

In the event that [construction] plans have been adopted ~~[which that]~~ [shall will] ultimately change a highway, the permittee may be required to construct entrances ~~[which that]~~ shall be compatible with the ~~[ultimate plans roadway's ultimate design]~~. The determination[s] to ~~[whether the entrances shall include curb and gutter require curb and gutter or other features at the proposed driveway]~~ shall be the responsibility of the engineer.

~~[In counties or cities which have ordinances or entrance standards which equal or exceed those of the Virginia Department of Transportation, then those of the county or city shall apply.~~

Ordinances or entrance standards established by counties or cities that exceed those of the Virginia Department of Transportation supersede those of the department.]

Minimum Standards of Entrances to State Highways

The permittee shall be required to supply sufficient information for the department to determine entrance design features to adequately serve the roadway facility as well as the proposed development. Detailed engineering plans and traffic analysis plans from a [~~certified professional firm~~ licensed design professional] may be required by the department.

To ensure the [~~maximum~~] efficiency of all commercial entrance designs certain general requirements shall be satisfied by each permittee. Consequently, potential applicants interested in using any individual designs shown in this chapter should first familiarize themselves with the prerequisites specified in 24 VAC 30-71-60 through 24 VAC 30-71-150.

24 VAC 30-71-60. Bonds, guarantee fees and irrevocable letters of credit.

All bonds prepared on form MP-20 shall indicate what permit the bond is for and define what type of work the bond covers, listing permit number and indicating whether it is a continuing bond or a performance bond. The estimated amount of the bond shall be the amount the resident engineer anticipates it will take to complete or restore the work should the permittee fail to complete the work.

A guarantee fee is a cash amount paid by the proposed permittee in advance of permit issuance to cover the performance of work within highway right-of-way. When work covered by the permittee is completed to the satisfaction of the resident engineer, the guarantee fee is refunded in its entirety to the permittee. Should the permittee fail to complete the work to the satisfaction of the resident engineer, then all or whatever portion of the guarantee fee that is required to complete work covered by permit or restore the right-of-way to its original condition shall be retained by the department.

Minimum Standards of Entrances to State Highways

An irrevocable letter of credit may be used instead of a guarantee fee or performance bond. This letter of credit is furnished by a bank and is used to verify a line of credit that will be set aside to provide for coverage of work performed by the permittee or his agent in accordance with the approved permit. (For more information on permit charges, see the Land Use Permit Manual, 24 VAC 30-150-10 et seq.)

24 VAC 30-71-70. Location.

To prevent undue interference with free traffic movements, entrance[s] [locations] shall be avoided within ~~intersectional~~ functional intersection areas, traffic circles or roundabouts, railroad grade crossings, interchanges or similar areas of traffic congestion. It is essential that designs allow unimpeded traffic movements entering or exiting. Parking and storage spaces shall be located a [~~reasonable~~ sufficient] distance from the entrance [~~location~~] to prevent interference with vehicles attempting to enter or exit the facility [or cause disruption to the fronting road]. [Managing appropriate access is critical to the function of an entrance.]

To reduce the number of points of access to state highways, joint use entrances are recommended if agreement can be reached by the owners. For a joint use entrance to be approved by the department, a copy of the property owner's recorded agreement shall be submitted to the department. [The department encourages cross-access easements from adjoining properties.]

24 VAC 30-71-80. Construction.

Minimum Standards of Entrances to State Highways

The type and depth of pavement shall be clearly indicated on the permit application. The pavement of entrances, turn lanes, and tapers shall be of stable material ~~which~~ that is at least comparable to the pavement of the adjacent roadway.

On-site parking shall be designed so as not to interfere with sight distance and to prevent vehicular overhang on state right-of-way. Interior curbing should be set a minimum of two feet (0.61 meter) outside or beyond the right-of-way line and should extend the entire length of the parking area. When parking areas abut curbing sections with sidewalk, parked vehicles shall be kept a sufficient distance from the curbing by the use of parking bumpers, or other means, to prevent vehicle overhang over the sidewalk. The engineer shall determine the need for additional curbing along the right-of-way to the adjacent property line.

Mountable curb (standard CG-3 or CG-7 in the English (~~revised April 1995~~ effective February 2001) or metric (~~revised September~~ effective January 1997) versions of the Road and Bridge Standards, Volumes I and II) is required when constructed within the clear zone of a road [~~posted for a speed limit~~ with a design speed] greater than 40 miles per hour (60 kilometers per hour) in rural areas and 45 miles per hour (70 kilometers per hour) in urban and suburban areas. [~~However, mountable curb is not recommended adjacent to sidewalks, due to potential encroachment of a vehicle onto the sidewalk.~~]

All curbing and entrance gutters used to construct commercial entrances shall be installed in accordance with the Virginia Department of Transportation's Road and Bridge Standards, English (~~revised April 1995~~ effective February 2001) or metric (~~revised September~~ effective January 1997) measurement versions, and all material shall meet the department's certification.

Minimum Standards of Entrances to State Highways

The property owner or developer of commercial or industrial entrances or subdivision road entrances shall be responsible for the entire construction of the entrance in accordance with the provisions of the required permit.

24 VAC 30-71-90. Drainage.

Entrances shall be constructed so as not to impair drainage within the state's right-of-way, and so that surface water shall drain from the state[']s roadway.

Where deemed necessary by the engineer, copies of a complete drainage layout, based on a drainage study by a [~~qualified engineer~~ licensed design professional], shall be furnished by the permittee, along with his plans. This layout shall include the ultimate development and clearly show how the permittee proposes to handle the drainage and run-off from his development.

Pipe ends of culverts shall be reviewed independently by the engineer and grading or treatment at pipe ends shall be done in such a manner as to minimize any hazard the pipe ~~end~~ ends or structures may present to an [~~out-of-control~~ errant] vehicle.

24 VAC 30-71-100. Crossovers or Median Openings.

Crossovers or median openings between the main through lanes shall not be permitted at entrances being constructed under provisions of a permit unless determined necessary by the department, and then only in accordance with the current policy on crossovers or median openings as outlined in this chapter and the department's Road Design Manual, English (~~revised October 1996~~) or metric (~~revised September 1996~~) measurement versions (effective July 1998) [with all subsequent revisions]. All crossover or median opening locations shall be approved by the district traffic engineer.

Minimum Standards of Entrances to State Highways

Crossovers or median openings that do not meet the standards as outlined in the department's Road Design Manual, English (~~revised October 1996~~) or metric (~~revised September 1996~~) measurement versions (effective July 1998) [with all subsequent revisions] shall be reviewed by the state [~~traffic~~ mobility management] engineer and the state location and design engineer.

If the department determines that a crossover or median opening is permissible, the permittee shall be responsible for the entire cost and construction, including turn lanes, traffic signal system, or both, as deemed necessary by the [chief] engineer [of operations].

24 VAC 30-71-110. Auxiliary lanes, [acceleration lanes,] right turn lanes and left turn lanes.

The need for auxiliary [lanes, acceleration] lanes, right turn lanes and left turn lanes shall be jointly determined by the district traffic engineer and resident engineer in accordance with [~~the department's latest design and construction criteria~~ the guidance in Appendix "C"] included in the English (~~revised October 1996~~) or metric (~~revised September 1996~~) measurement versions (effective July 1998) [with all subsequent revisions] of the Road Design Manual. [The design and construction of these lanes shall conform to the criteria shown in the Road Design Manual (effective July 1998) with all subsequent revisions.]

24 VAC 30-71-120. Curb ramps for persons with mobility impairments.

Ramps in curb sections [~~to aid the physically handicapped~~] shall be provided as required in § ~~15.1-384~~ 15.2-2021 of the Code of Virginia. ~~A~~ The standard drawing ~~of the~~ for depressed curb ramp (CG-12[A, CG-12B, CG-12C]) ~~is as~~ shown in the Road and Bridge Standards, English (~~revised April 1995~~ effective February 2001) or metric (~~revised September~~ effective

Minimum Standards of Entrances to State Highways

January 1997) measurement versions [or applicable insertable sheet] shall be utilized in the design.

24 VAC 30-71-130. Sight distances.

The following shall be utilized to evaluate [intersection] sight distance. [The sight distance requirements pertaining to commercial driveways are not classified as vertical and horizontal, but are intersection sight distance requirements being composed of both vertical and horizontal components.] Vertical sight distance shall be determined from [a target an object] mounted [4.25 3.5] feet ([1.30 1.08] meters) above the grade of the vehicle path simulating a vehicle entering or exiting the entrance traveling the through lanes of the roadway. The sight distance shall be measured from an eye height of 3.5 feet ([1.07 1.08] meters) to the [target object]. Horizontal sight distance shall be determined from an eye height of 3.5 feet ([1.07 1.08] meters) with the object being [4.25 3.5] feet ([1.30 1.08] meters). For more information on sight distance, see the 1994 edition of A Policy on Geometric Design of Highways and Streets, published by the American Association of State Highway and Transportation Officials. [For more information on sight distance, see AASHTO's 2001 edition of A Policy on Geometric Design of Highways and Streets.]

On a typical two-lane road with a horizontal curve, numerous objects restrict sight distance.

These include, but are not limited to, cut slopes, buildings, vegetation, [signs,] and vehicles.

Landscaping in these areas shall conform to the [Chief Engineer's memorandum entitled "Guidance for Planting in the Clear Zone and Landscaping for VDOT Projects" dated October 31, 2000, pending completion of an updated VDOT Environmental Division's Planting

Minimum Standards of Entrances to State Highways

~~Guidelines Manual, effective 1990~~ AASHTO 2001 edition of A Policy on Geometric Design of Highways and Streets. It is possible to have sight distance in the winter and not in the spring or summer due to the growth of vegetation. These obstructions should be considered when reviewing a commercial entrance permit. A divided highway may have similar problems. It is ~~important~~ critical to obtain at least the ~~desirable~~ minimum commercial entrance sight distance from the entrance as well as the left turn position into the entrance. Any waiver of the required sight distance may only be granted by the chief engineer [for program development] or the ~~assistant commissioner for operations~~ state location and design engineer after a traffic engineering investigation has been conducted. [Refer to the Guidance Document Instructional and Informational Memorandum (IIM) LD-227.1, dated January 15, 2003, for requirements concerning Federal Highway Administration (FHWA) approval of sight distance waiver.]

Table 1 shows specific information about sight distances and speeds along major roads:

Minimum Standards of Entrances to State Highways

Table 1 Sight Distances Along Major Roads at Intersections with Minor Roads, Crossovers or Median Openings, and Commercial Entrances (English measurements [Measurements])							
Height of Eye (3.5 ft.)	Height of Object ([4.25 3.5] ft)						
Speed Limit [Design Speed]* Miles per hour (mph)	25 mph	30 mph	35 mph	40 mph	45 mph	50 mph	55 mph
{Two and Three Lane Road or Four Lane Divided Highways not at Crossovers 2 or 3 Lane Major Road+}	[250 280] ft	[300 335] ft.	[350 390] ft.	[400 445] ft.	[450 500] ft.	[500 555] ft.	[550 610] ft.
{Four 4} Lane** [Major Road Undivided (4 Lane Divided Highways at Crossovers - Minimum Sight Distance)] Undivided and Four Lane Divided Highways at Crossovers}	[300 295] ft.	[350 355] ft.	[425 415] ft.	475 ft.	[525 530] ft.	[600 590] ft.	650 ft.
4 Lane ** Major Road (Divided -18 ft. Median)	325 ft.	390 ft.	455 ft.	520 ft.	580 ft.	645 ft.	710 ft.
Sight Distances Along Major Roads at Intersections with Minor Roads, Crossovers or Median Openings, and Commercial Entrances (Metric Measurements)							
Height of Eye ([1.07 1.08] m.)	Height of Object ([1.30 1.08] m.)						
Design Speed (km/h)*	40 km/h	50 km/h	60 km/h	70 km/h	80 km/h	90 km/h	
{Two 2 or 3} Lane Major Road+	[75 85] m.	[95 105] m.	[115 130] m.	[135 150] m.	[150 170] m.	[170 190] m.	[190] m.
{Four 4} Lane Major Road [Undivided (4 Lane Divided Highways at Crossovers - Minimum Sight Distance)]	[85 90] m.	[110 115] m.	[130 135] m.	[150 160] m.	[175 180] m.	[195 205] m.	[205] m.
{Four 4} Lane Major Road** (Divided – 5.4 m. Median)	[95 100] m.	[115 125] m.	[140 150] m.	[165 175] m.	[185 195] m.	[210 220] m.	[220] m.

*[Legal speed limit may be used at the engineer’s discretion.] Where the operating speed on the respective segment of highway is determined to be lower than the legal speed limit, and, in the judgment of the engineers, the operating speed shall not create hazards for either a driver at a connection or on the major roadway and the legal speed limit cannot and, in all probability, shall not be obtained in the foreseeable future as a result of improvement or reconstruction, the sight distance requirements for the operating speed may then be applied. [Where the operating speed on the respective segment of highway is determined to be higher than the legal speed limit, the engineer may

Minimum Standards of Entrances to State Highways

require, in the interest of public safety, that the sight distance requirement for the operating speed be applied.]The operating speed shall be determined by a traffic engineering study at the location in question. In all cases when the operating speed is used in lieu of the speed limit, full documentation of its determination shall be attached to the permit assembly. [For roadways with Design Speeds lower or higher than those shown, refer to the Road Design Manual (effective July 1998) with all subsequent revisions.]

**For median widths greater than 60 feet (18 meters), each roadway can be considered as a separate two, three, or four-lane roadway. (See the [~~1994~~ 2001] edition of [AASHTO's] A Policy on Geometric Design of Highways and Streets.)

[+For three-lane major roads, where crossing two opposing travel lanes, use the four-lane sight distance. When crossing one opposing travel lane, use two-lane sight distance.]

24 VAC 30-71-140. Tenure of commercial entrances.

A. Tenure of all commercial entrances to highways is finite and is not meant to be transferred from one owner to another. If department representatives determine that an entrance is substandard or that safety, use, or maintenance of the entrance has changed significantly enough to require corrections, then necessary changes shall be made or the entrance may be closed at the direction of the commissioner or his representative. It should also be noted that once an entrance has been constructed (regardless of date), the permittee or his successors or assignees shall be responsible for the maintenance and upkeep of the entrance as stated above.

B. Commercial entrances may require reconstruction or upgrading, or both, when department representatives determine after review that the following conditions exist:

1. Safety. When the entrance has been determined to be unsafe in its present condition for public use because of physical erosion of the entrance, increase in motor vehicle traffic, or some other condition is found to exist.

Minimum Standards of Entrances to State Highways

2. Use. When traffic in and out of the entrance has changed significantly to require upgrading or reconstruction, or both. Such changes may include, but are not limited to changes in traffic volume, character of the traffic or peak hour traffic. This language is not intended to be exclusive.

3. Maintenance. When the entrance becomes unserviceable due to heavy equipment damage, reclamation by natural causes, or increased traffic volume, etc.

C. Commercial entrances shall be reviewed periodically for substandard conditions as outlined above and when the property is being considered for sale, has been rezoned, or when there is a change in commercial use either by the property owner or by a lessee. Department personnel shall work closely with the various local and county governments to protect the department's interest and the interest of the traveling public through zoning ordinances for commercial, subdivision and private entrance requirements, and to obtain their assistance in policing changes in ownership that might affect the department's requirements for the entrances. These periodic reviews are necessary to provide both patron and through-highway-traffic users a safe means of travel.

Minimum Standards of Entrances to State Highways

The department is responsible for the maintenance of that portion of the entrance within the normal shoulder as shown in Figure 1.

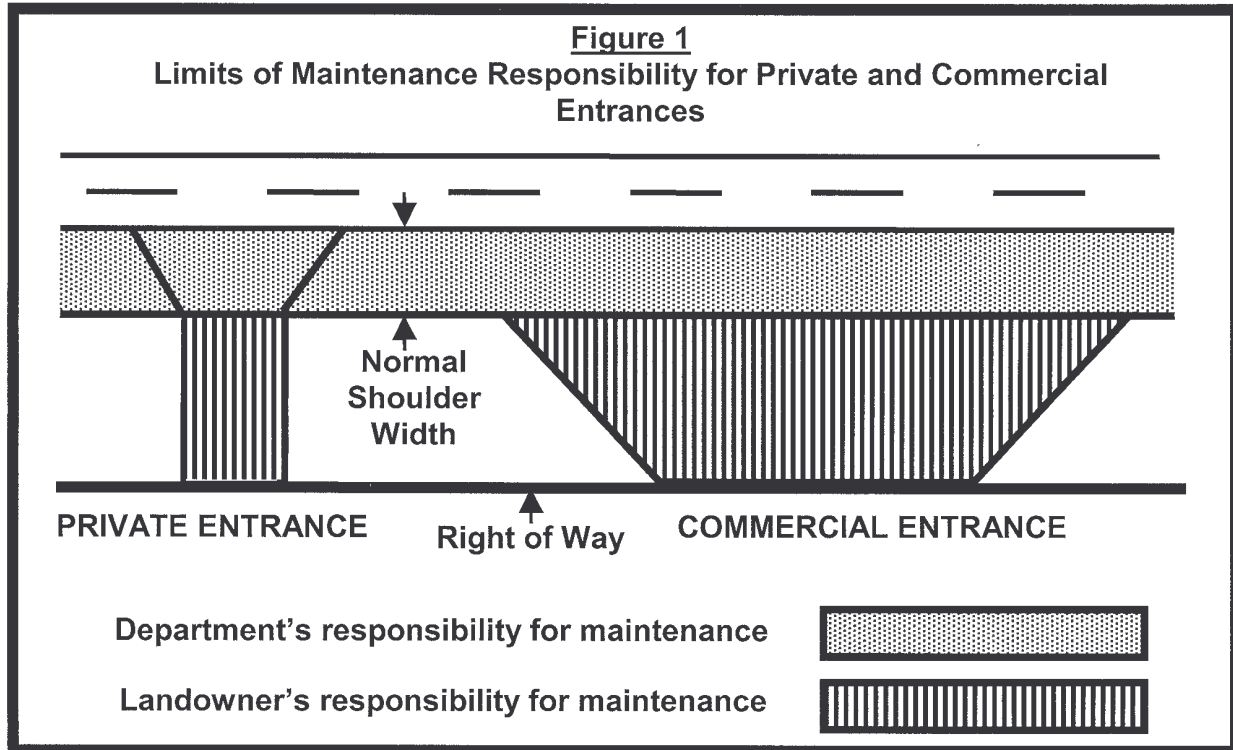

24 VAC 30-71-150. Developer participation in traffic signal cost.

The following guidelines have been developed in an effort to obtain an equitable method of determining developer responsibility for participation in funding traffic signal work necessitated by land development:

1. Where the proposed development will generate sufficient traffic to warrant signalization, the total cost for design, materials, timing plans, and installation shall be borne by the developer.

Minimum Standards of Entrances to State Highways

2. Where development-generated traffic and existing highway traffic must be combined to meet the requirements for either the major or minor movements for any hour or hours, the developer shall bear 50% of the total cost for design materials, timing plans, and installation.
3. Where an existing traffic signal must be modified to accommodate traffic movements to or from the development, the developer shall bear the total cost for any design, materials, timing plans, installation, and relocation required to accommodate the development traffic.

For large developments, such as regional shopping centers and corporate complexes, the department reserves the right to require that the developer design or have designed the traffic signal, including timing plans, and to install or have installed a complete working ~~installation~~ traffic signal system. Designs and installations shall be in accordance with the current departmental specifications and standards and shall be approved by the engineer.

Minimum Standards of Entrances to State Highways

24 VAC 30-71-160. Commercial/private entrance design illustrations.

The details set forth in the illustrations contained in this section may be reduced or modified if approved by the district administrator or engineer. [All entrance widths in the following illustrations shall be determined at the throat of the entrance, not the right of way line.]

Minimum Standards of Entrances to State Highways

COMMERCIAL ENTRANCE DESIGNS
ALONG HIGHWAYS WITH SHOULDERS

(English Units)

SINGLE TWO-WAY ENTRANCE

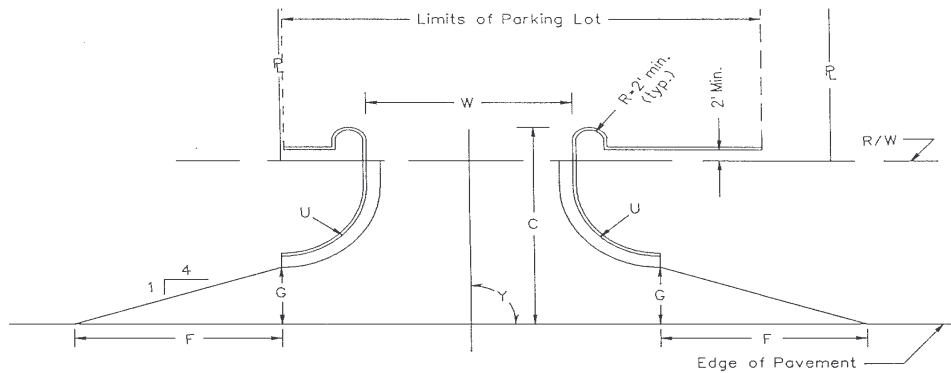

SINGLE TWO-WAY ENTRANCE
WITH RIGHT TURN LANE AND TAPER

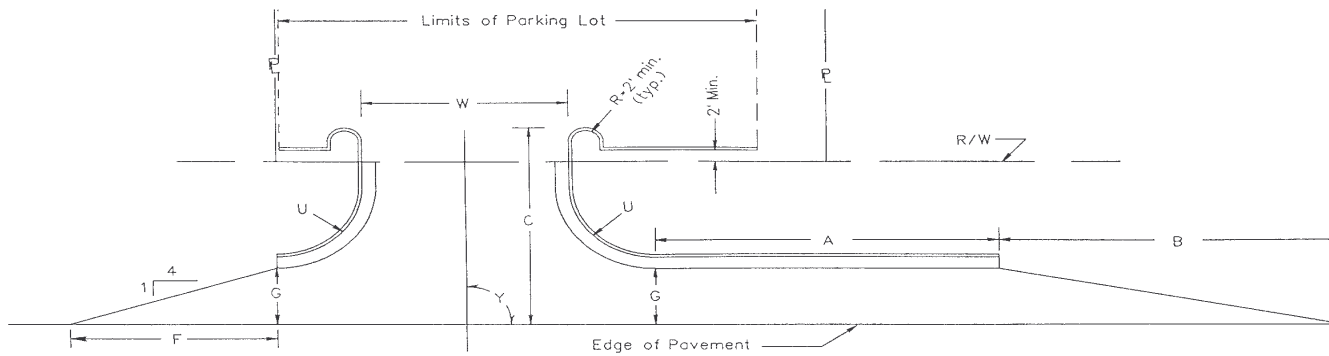

LETTER SYMBOL	DIMENSIONS
A	As determined by the Engineer
B	100' or greater.
C	25' or greater. In developing areas where it is anticipated that the right turn lane will become a continuous thru lane in the future, an additional 12' is recommended.
F	48' or greater.
G	12'
U	12.5' - 50'. The radii selected shall accommodate the anticipated type of vehicle usage. Larger radii should be considered by the designer or may be required by the Engineer if larger vehicles are anticipated; however, in no case shall radius be less than 12.5'.
W	30' - 40'
Y	60° - 90°

Notes:
Entrance details shown on this sheet may be modified to meet specific site requirements as directed or approved by the Engineer, when based on sound engineering principles.

If an Accessible route as defined in 24 VAC 30-71-10 is present, curb ramps in accordance with St'd. CG-12 will be provided.

Minimum Standards of Entrances to State Highways

COMMERCIAL ENTRANCE DESIGNS
ALONG HIGHWAYS WITH SHOULDERS

(Metric Units)

SINGLE TWO-WAY ENTRANCE

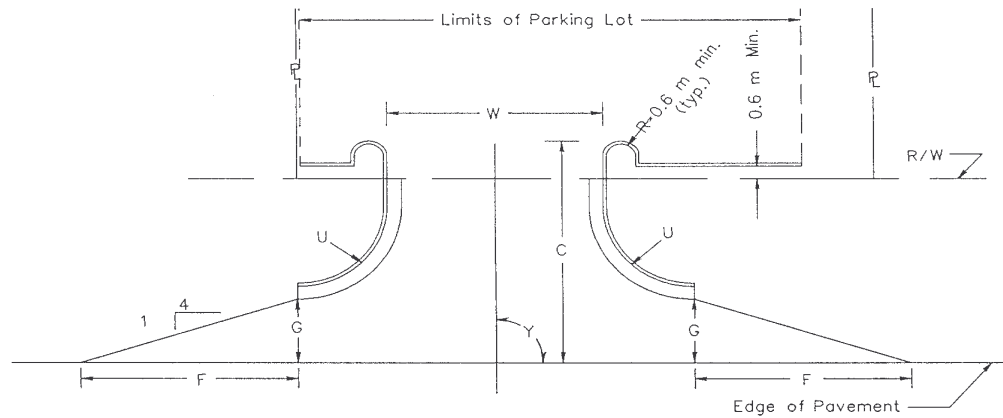

SINGLE TWO-WAY ENTRANCE
WITH RIGHT TURN LANE AND TAPER

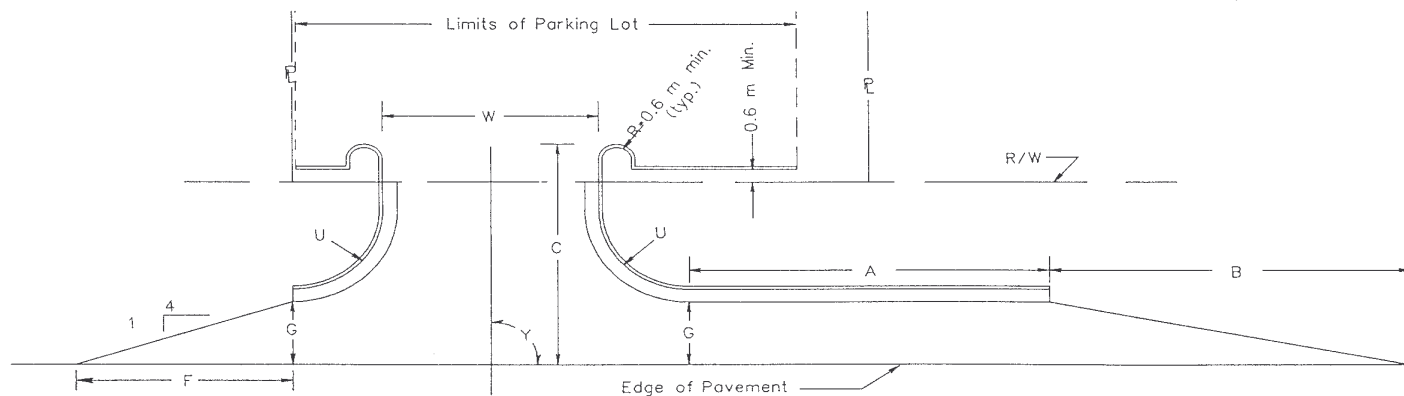

LETTER
SYMBOL

DIMENSIONS

A	As determined by the Engineer
B	30 m or greater.
C	7.5 m or greater. In developing areas where it is anticipated that the right turn lane will become a continuous thru lane in the future, an additional 3.6 m is recommended.
F	14.4 m or greater.
G	3.6 m
U	3.8 m - 15 m. The radii selected shall accommodate the anticipated type of vehicle usage. Larger radii should be considered by the designer or may be required by the Engineer if larger vehicles are anticipated; however, in no case shall radius be less than 3.8 m.
W	9 m - 12 m
Y	60° - 90°

Notes:

Entrance details shown on this sheet may be modified to meet specific site requirements as directed or approved by the Engineer, when based on sound engineering principles.

If an Accessible route as defined in page 24 VAC 30-71-10 is present, curb ramps in accordance with St'd. CG-12 will be provided.

Minimum Standards of Entrances to State Highways

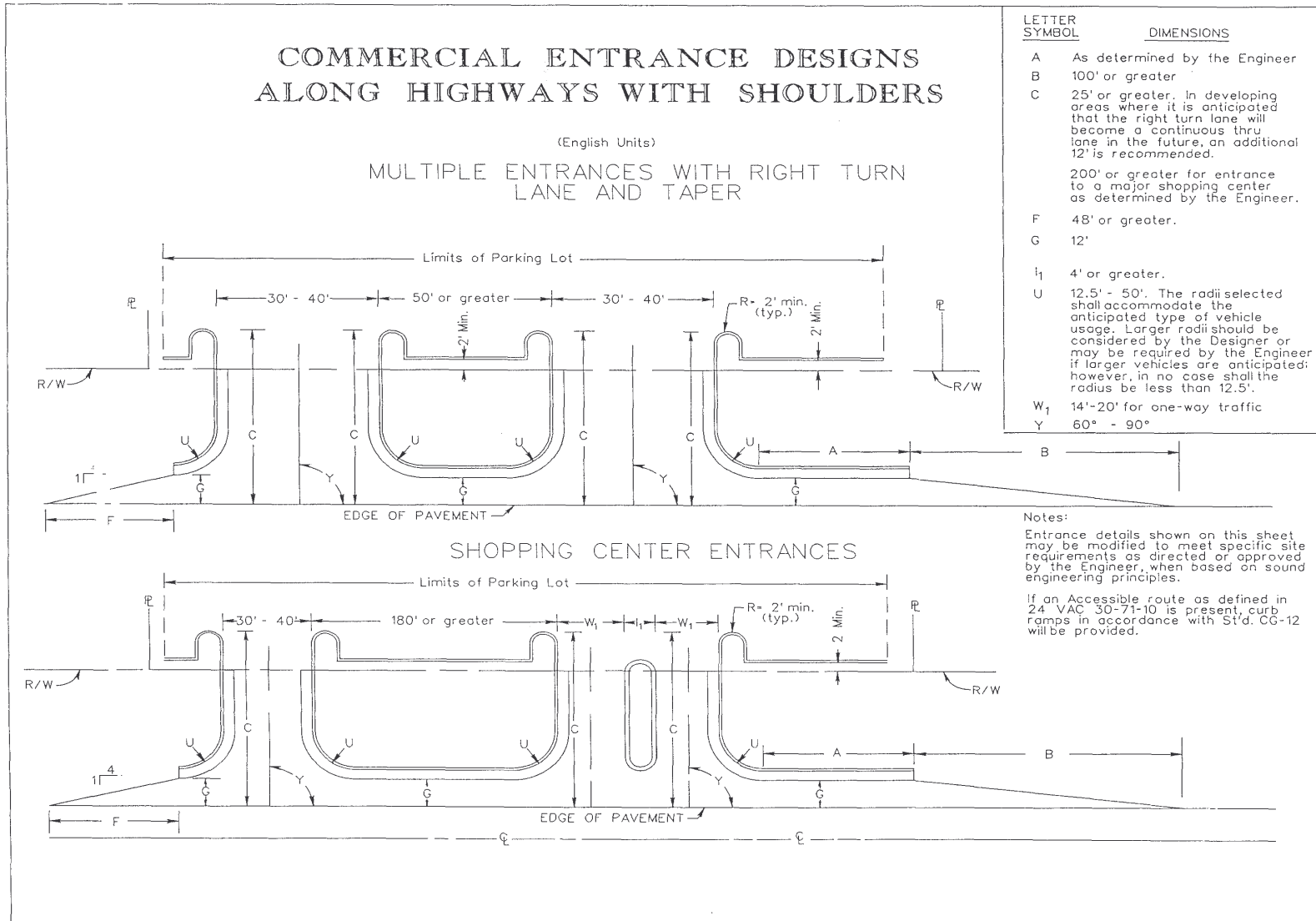

Minimum Standards of Entrances to State Highways

COMMERCIAL ENTRANCE DESIGNS
ALONG HIGHWAYS WITH SHOULDERS

(Metric Units)

MULTIPLE ENTRANCES WITH RIGHT TURN
LANE AND TAPER

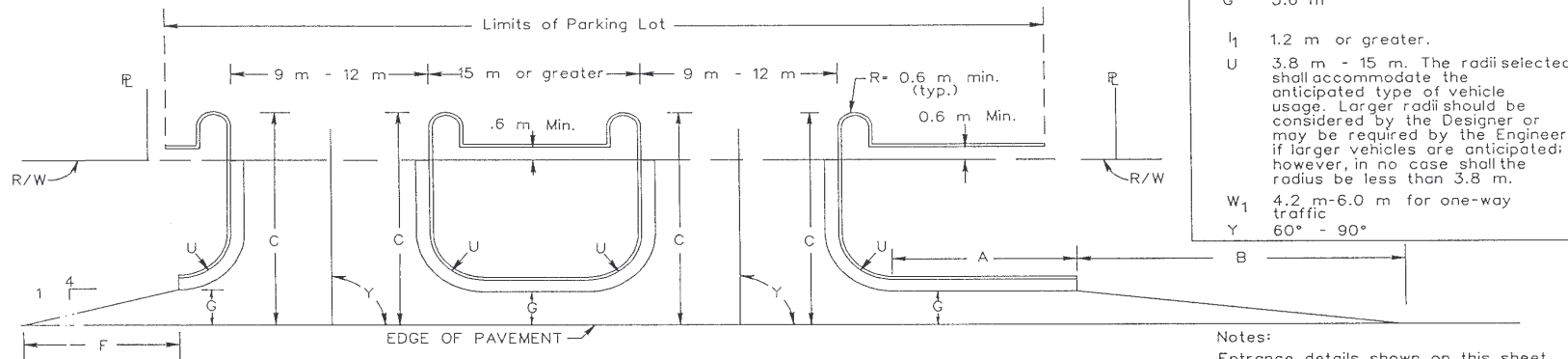

LETTER SYMBOL	DIMENSIONS
A	As determined by the Engineer
B	30 m or greater
C	7.5 m or greater. In developing areas where it is anticipated that the right turn lane will become a continuous thru lane in the future, an additional 3.6 m is recommended.
F	60 m or greater for entrance to a major shopping center as determined by the Engineer.
F	14.4 m or greater.
G	3.6 m
U ₁	1.2 m or greater.
U	3.8 m - 15 m. The radii selected shall accommodate the anticipated type of vehicle usage. Larger radii should be considered by the Designer or may be required by the Engineer if larger vehicles are anticipated; however, in no case shall the radius be less than 3.8 m.
W ₁	4.2 m-6.0 m for one-way traffic
Y	60° - 90°

SHOPPING CENTER ENTRANCES

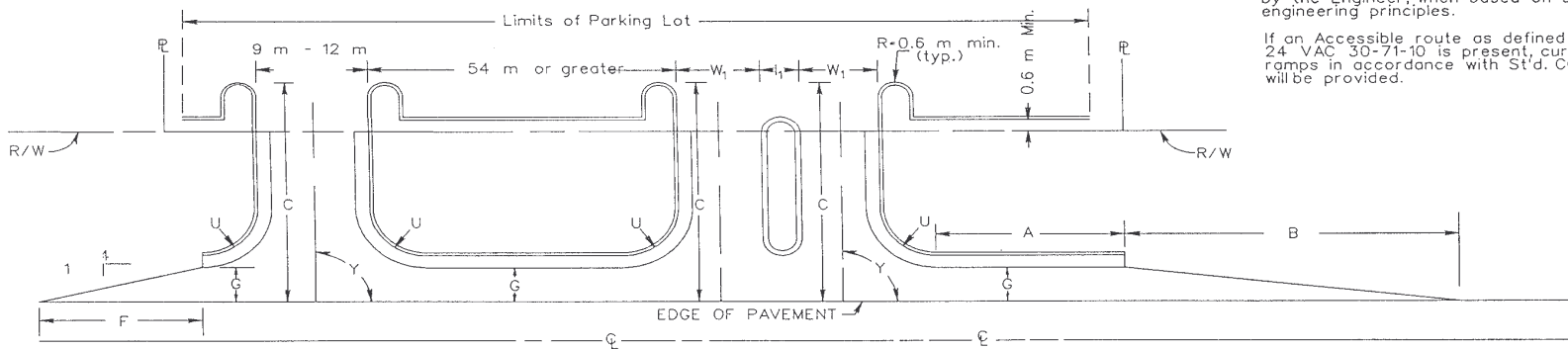

Notes:
Entrance details shown on this sheet may be modified to meet specific site requirements as directed or approved by the Engineer, when based on sound engineering principles.
If an Accessible route as defined in 24 VAC 30-71-10 is present, curb ramps in accordance with Std. CG-12 will be provided.

Minimum Standards of Entrances to State Highways

COMMERCIAL ENTRANCE DESIGNS
ALONG HIGHWAYS WITH SHOULDERS

(English Units)

MULTIPLE ENTRANCES AT INTERSECTIONS

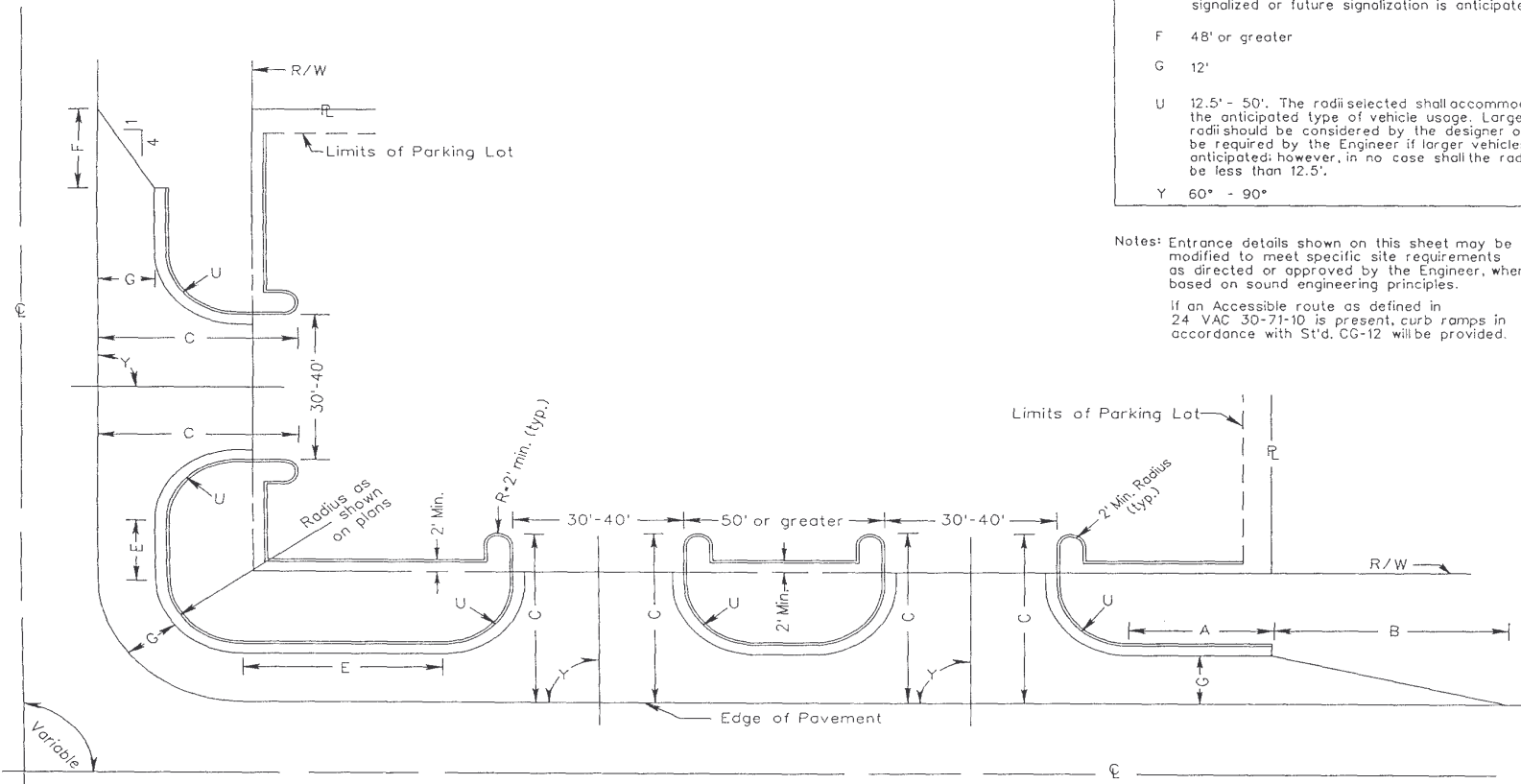

LETTER SYMBOL

DIMENSIONS

- A As determined by the Engineer
- B 100' or greater
- C 25' or greater. In developing areas where it is anticipated that the right turn lane will become a continuous thru lane in the future, an additional 12' is recommended.
200' or greater for entrance to a major shopping center as determined by the engineer.
- E 50' or greater (additional length will be required as directed by the Engineer if intersection is signalized or future signalization is anticipated).
- F 48' or greater
- G 12'
- U 12.5' - 50'. The radii selected shall accommodate the anticipated type of vehicle usage. Larger radii should be considered by the designer or may be required by the Engineer if larger vehicles are anticipated; however, in no case shall the radius be less than 12.5'.
- Y 60° - 90°

Notes: Entrance details shown on this sheet may be modified to meet specific site requirements as directed or approved by the Engineer, when based on sound engineering principles.
If an Accessible route as defined in 24 VAC 30-71-10 is present, curb ramps in accordance with St'd. CG-12 will be provided.

Minimum Standards of Entrances to State Highways

COMMERCIAL ENTRANCE DESIGNS
ALONG HIGHWAYS WITH SHOULDERS

(Metric Units)

MULTIPLE ENTRANCES AT INTERSECTIONS

LETTER SYMBOL	DIMENSIONS
A	As determined by the Engineer
B	30 m or greater
C	7.5 m or greater. In developing areas where it is anticipated that the right turn lane will become a continuous thru lane in the future, an additional 3.6 m is recommended. 60 m, or greater for entrance to a major shopping center as determined by the engineer.
E	15 m or greater (additional length will be required as directed by the Engineer if intersection is signalized or future signalization is anticipated).
F	14.4 m or greater
G	3.6 m
U	3.8 m - 15 m. The radius selected shall accommodate the anticipated type of vehicle usage. Larger radii should be considered by the designer or may be required by the Engineer if larger vehicles are anticipated; however, in no case shall the radius be less than 3.8 m.
Y	60° - 90°

Notes: Entrance details shown on this sheet may be modified to meet specific site requirements as directed or approved by the Engineer, when based on sound engineering principles.

If an Accessible route as defined in 24 VAC 30-71-10 is present, curb ramps in accordance with St'd. CG-12 will be provided.

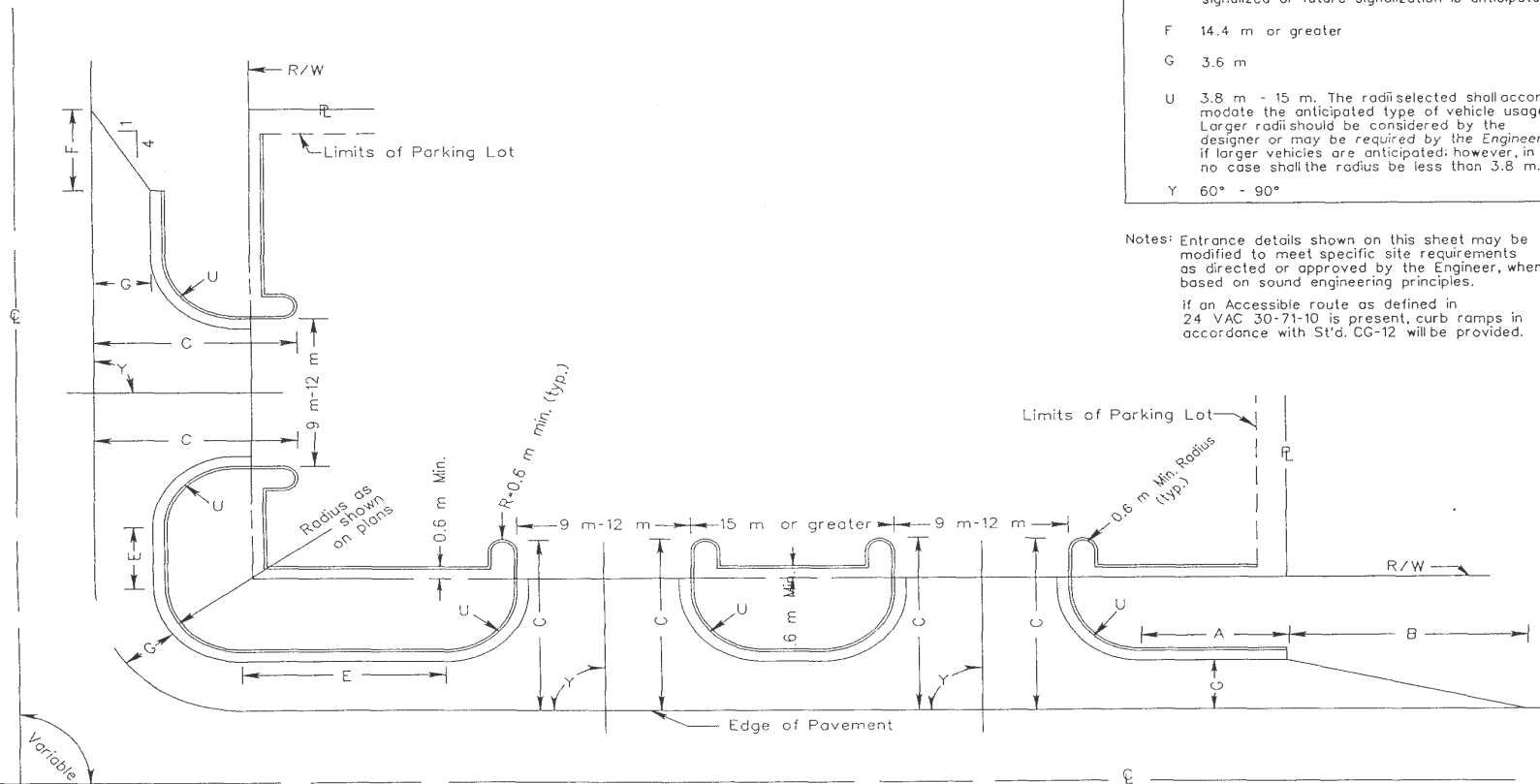

Minimum Standards of Entrances to State Highways

COMMERCIAL ENTRANCE DESIGNS
ALONG HIGHWAYS WITH CURB AND GUTTER

(English Units)

MULTIPLE ENTRANCES
WITH RIGHT TURN LANE AND TAPER

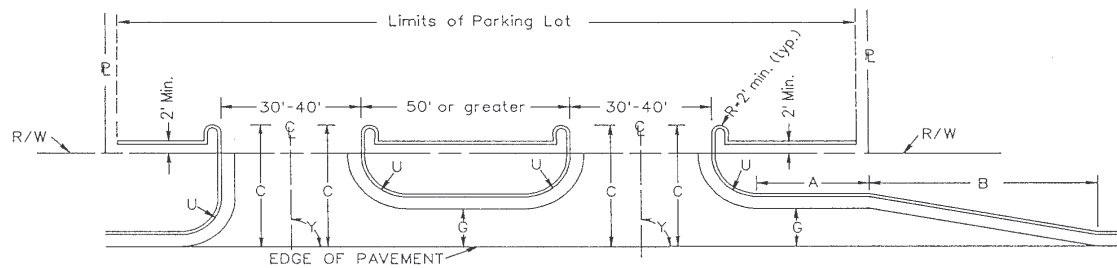

TWO ONE-WAY ENTRANCES
WITH RIGHT TURN LANE AND TAPER

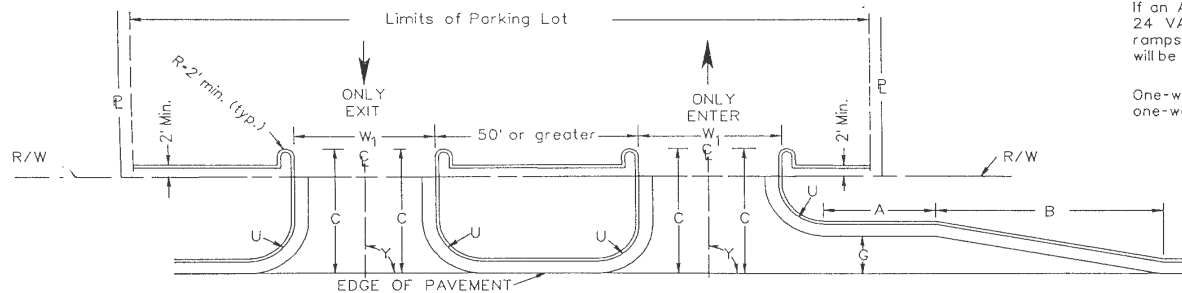

LETTER SYMBOL	DIMENSIONS
A	As determined by the Engineer.
B	100' or greater.
C	25' or greater. In developing areas where it is anticipated that the right turn lane will become a continuous thru lane in the future, an additional 12' is recommended.
	200' or greater for entrance to a major shopping center as determined by the Engineer.
G	12'
U	12.5' to 50'. The radii selected shall accommodate the anticipated type of vehicle usage. Larger radii should be considered by the Designer or may be required by the Engineer if larger vehicles are anticipated; however, in no case shall the radius be less than 12.5'.
W ₁	14'-20' for one-way traffic.
Y	60° - 90°

Notes: Entrance details shown on this sheet may be modified to meet specific site requirements as directed or approved by the Engineer, when based on sound engineering principles.

If an Accessible route as defined in 24 VAC 30-71-10 is present, curb ramps in accordance with St'd. CG-12 will be provided.

One-way entrances must be signed one-way.

Minimum Standards of Entrances to State Highways

COMMERCIAL ENTRANCE DESIGNS
ALONG HIGHWAYS WITH CURB AND GUTTER

(Metric Units)

MULTIPLE ENTRANCES
WITH RIGHT TURN LANE AND TAPER

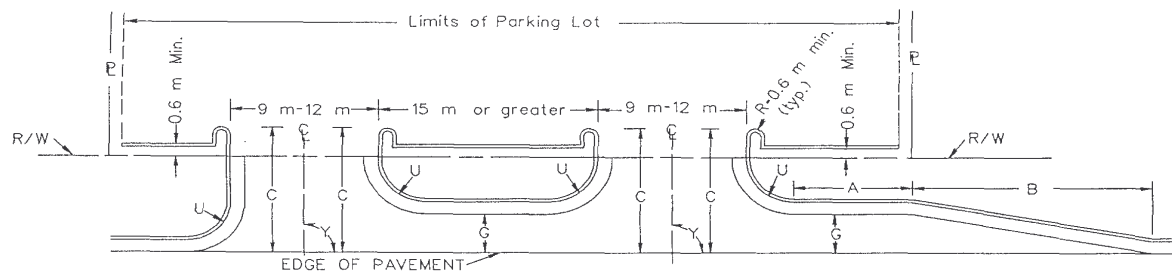

TWO ONE-WAY ENTRANCES
WITH RIGHT TURN LANE AND TAPER

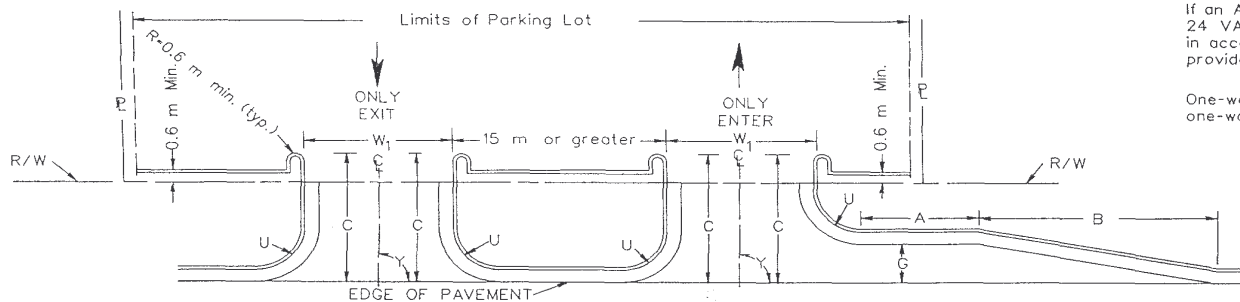

LETTER SYMBOL	DIMENSIONS
A	As determined by the Engineer.
B	30 m or greater.
C	7.5 m or greater. In developing areas where it is anticipated that the right turn lane will become a continuous thru lane in the future, an additional 3.6 m is recommended.
G	10 m or greater for entrance to a major shopping center as determined by the Engineer.
U	3.6 m
U	3.8 m to 15 m. The radii selected shall accommodate the anticipated type of vehicle usage. Larger radii should be considered by the Designer or may be required by the Engineer if larger vehicles are anticipated; however, in no case shall the radius be less than 3.8 m.
W ₁	4.2 m-6.0 m for one-way traffic.
Y	60° - 90°

Notes: Entrance details shown on this sheet may be modified to meet specific site requirements as directed or approved by the Engineer, when based on sound engineering principles.

If an Accessible route as defined in 24 VAC 30-71-10 is present, curb ramps in accordance with Std. CG-12 will be provided.

One-way entrances must be signed one-way.

Minimum Standards of Entrances to State Highways

COMMERCIAL ENTRANCE DESIGNS ALONG HIGHWAYS WITH CURB AND GUTTER

(English Units)

MULTIPLE ENTRANCES WITH RIGHT TURN LANES
AND TAPER FOR SHOPPING CENTER ENTRANCES

LETTER SYMBOL	DIMENSIONS
A	As determined by the Engineer
B	100' or greater
C	25' or greater. In developing areas where it is anticipated that the right turn lane will become a continuous thru lane in the future, an additional 12' is recommended.
G	200' or greater for entrance to a major shopping center as determined by the Engineer.
12'	12'
I ₁	4' or greater
U	12.5'-50'. The radii selected shall accommodate the anticipated type of vehicle usage. Larger radii should be considered by the designer or may be required by the Engineer if larger vehicles are anticipated; however, in no case shall the radius be less than 12.5'.
W ₁	14'-20' for one-way traffic
Y	60° -90°

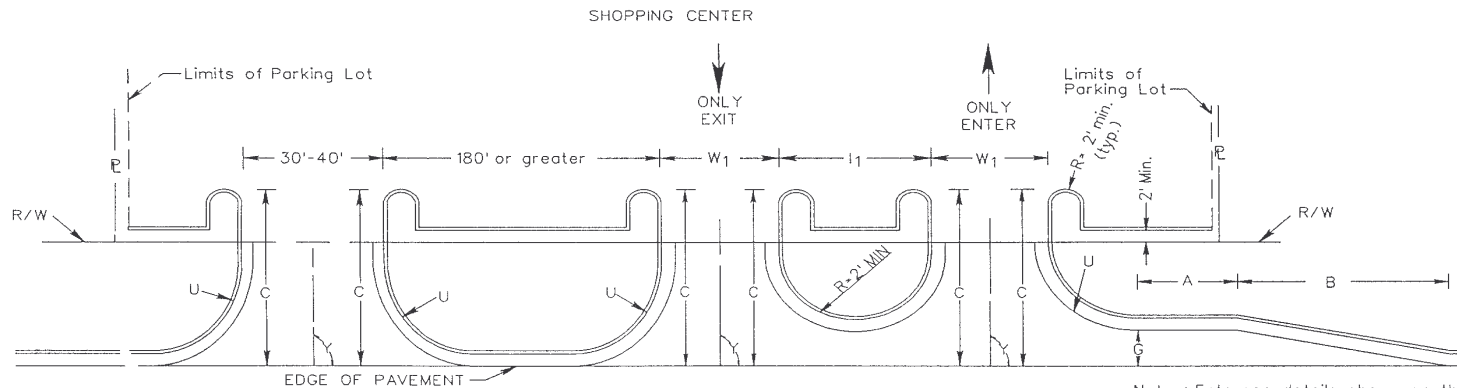

Notes: Entrance details shown on this sheet may be modified to meet specific site requirements as directed or approved by the Engineer, when based on sound engineering principles.

If an Accessible route as defined in 24 VAC 30-71-10 is present, curb ramps in accordance with St'd CG-12 will be provided.

One-way entrances must be signed one-way

Minimum Standards of Entrances to State Highways

COMMERCIAL ENTRANCE DESIGNS ALONG HIGHWAYS WITH CURB AND GUTTER

(Metric Units)

MULTIPLE ENTRANCES WITH RIGHT TURN LANES
AND TAPER FOR SHOPPING CENTER ENTRANCES

LETTER SYMBOL	DIMENSIONS
A	As determined by the Engineer
B	30 m or greater
C	7.5 m or greater. In developing areas where it is anticipated that the right turn lane will become a continuous thru lane in the future, an additional 3.6 m is recommended.
G	3.6 m
I ₁	1.2 m or greater
U	3.8 m-15 m. The radii selected shall accommodate the anticipated type of vehicle usage. Larger radii should be considered by the designer or may be required by the Engineer if larger vehicles are anticipated; however, in no case shall the radius be less than 3.8 m.
W ₁	4.2 m-6.0 m for one-way traffic
Y	60° -90°

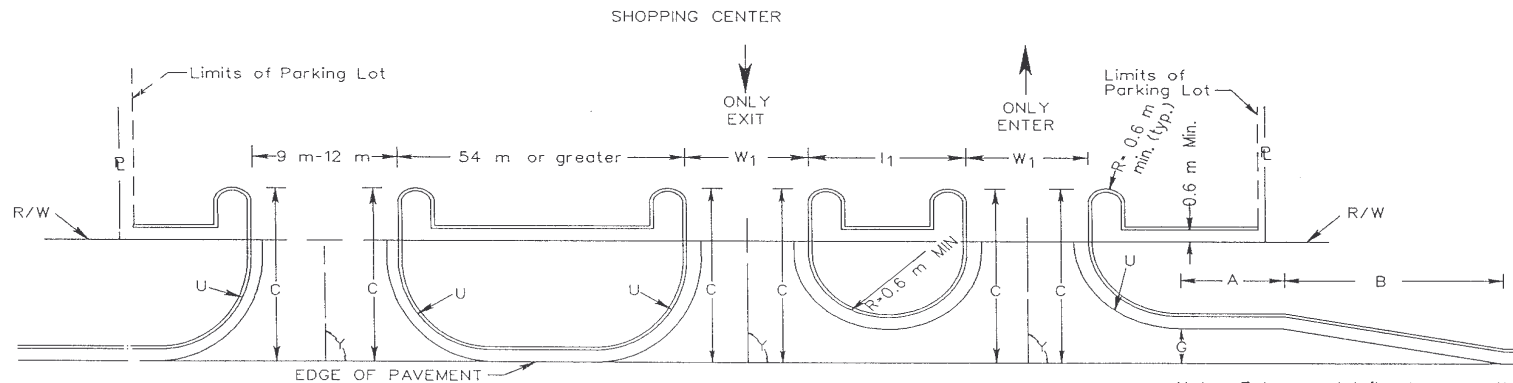

Notes: Entrance details shown on this sheet may be modified to meet specific site requirements as directed or approved by the Engineer, when based on sound engineering principles.

If an Accessible route as defined in 24 VAC 30-71-10 is present, curb ramps in accordance with Std. CG-12 will be provided.

One-way entrances must be signed one-way

Minimum Standards of Entrances to State Highways

COMMERCIAL ENTRANCE DESIGNS ALONG HIGHWAYS WITH CURB AND GUTTER

(English Units)

MULTIPLE ENTRANCES AT INTERSECTION WITH RIGHT TURN LANE AND TAPER

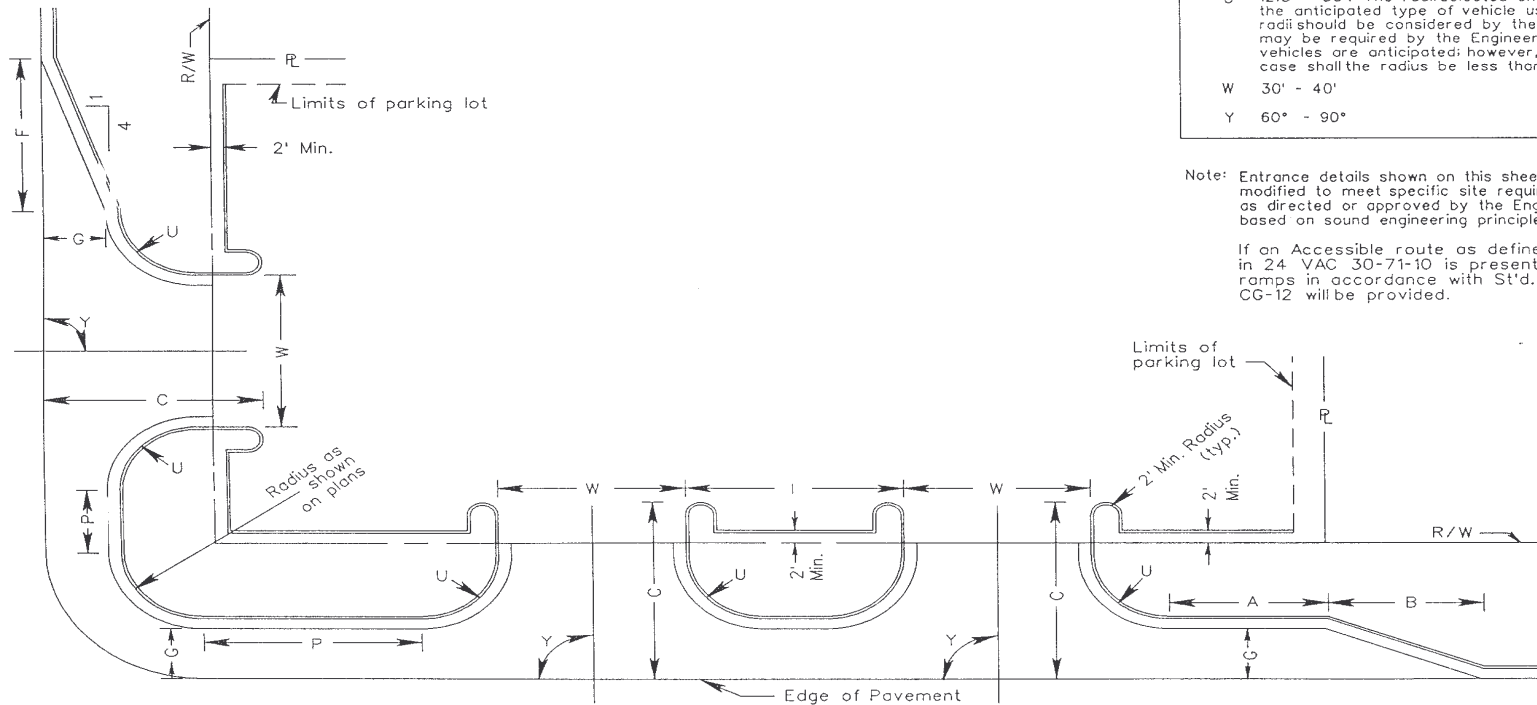

LETTER SYMBOL	DIMENSIONS
A	As determined by the Engineer
B	100' or greater.
C	25' or greater. In developing areas where it is anticipated that the right turn lane will become a continuous thru lane in the future, an additional 12' is recommended. 200' or greater for entrance to shopping center or other major traffic generator as determined by the engineer.
F	48' or greater.
G	12'
I	50' or greater.
P	50' or greater (additional length will be required as directed by the Engineer if intersection is signalized or future signalization is anticipated.)
U	12.5' - 50'. The radii selected shall accommodate the anticipated type of vehicle usage. Larger radii should be considered by the designer or may be required by the Engineer if larger vehicles are anticipated; however, in no case shall the radius be less than 12.5'.
W	30' - 40'
Y	60° - 90°

Note: Entrance details shown on this sheet may be modified to meet specific site requirements as directed or approved by the Engineer, when based on sound engineering principles.

If an Accessible route as defined in 24 VAC 30-71-10 is present, curb ramps in accordance with S't'd. CG-12 will be provided.

Minimum Standards of Entrances to State Highways

COMMERCIAL ENTRANCE DESIGNS ALONG HIGHWAYS WITH CURB AND GUTTER

(Metric Units)

MULTIPLE ENTRANCES AT INTERSECTION WITH RIGHT TURN LANE AND TAPER

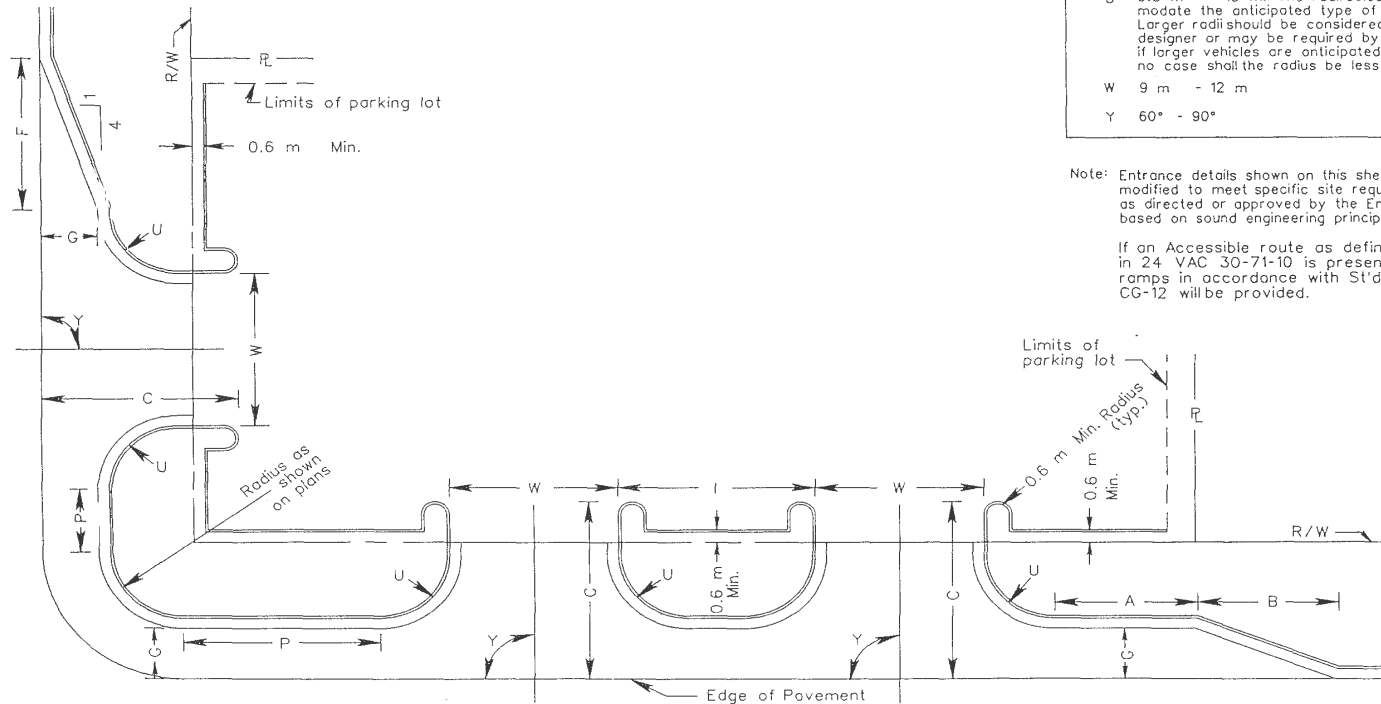

LETTER SYMBOL	DIMENSIONS
A	As determined by the Engineer
B	30 m or greater.
C	7.5 m or greater. In developing areas where it is anticipated that the right turn lane will become a continuous thru lane in the future, an additional 3.6 m is recommended. 60 m or greater for entrance to shopping center or other major traffic generator as determined by the engineer.
F	14.4 m or greater.
G	3.6 m
I	15 m or greater.
P	15 m or greater (additional length will be required as directed by the Engineer if intersection is signalized or future signalization is anticipated.)
U	3.8 m - 15 m. The radii selected shall accommodate the anticipated type of vehicle usage. Larger radii should be considered by the designer or may be required by the Engineer if larger vehicles are anticipated; however, in no case shall the radius be less than 3.8 m.
W	9 m - 12 m
Y	60° - 90°

Note: Entrance details shown on this sheet may be modified to meet specific site requirements as directed or approved by the Engineer, when based on sound engineering principles.

If an Accessible route as defined in 24 VAC 30-71-10 is present, curb ramps in accordance with St'd. CG-12 will be provided.

Minimum Standards of Entrances to State Highways

COMMERCIAL ENTRANCE DESIGNS TO SERVE DRIVE-IN TYPE BUSINESSES SUCH AS DRIVE-IN BANKS, FAST FOOD RESTAURANTS, SERVICE STATIONS, AND CAR WASHES WITH ONE WAY TRAFFIC ENTERING AND/OR EXITING MAJOR HIGHWAY

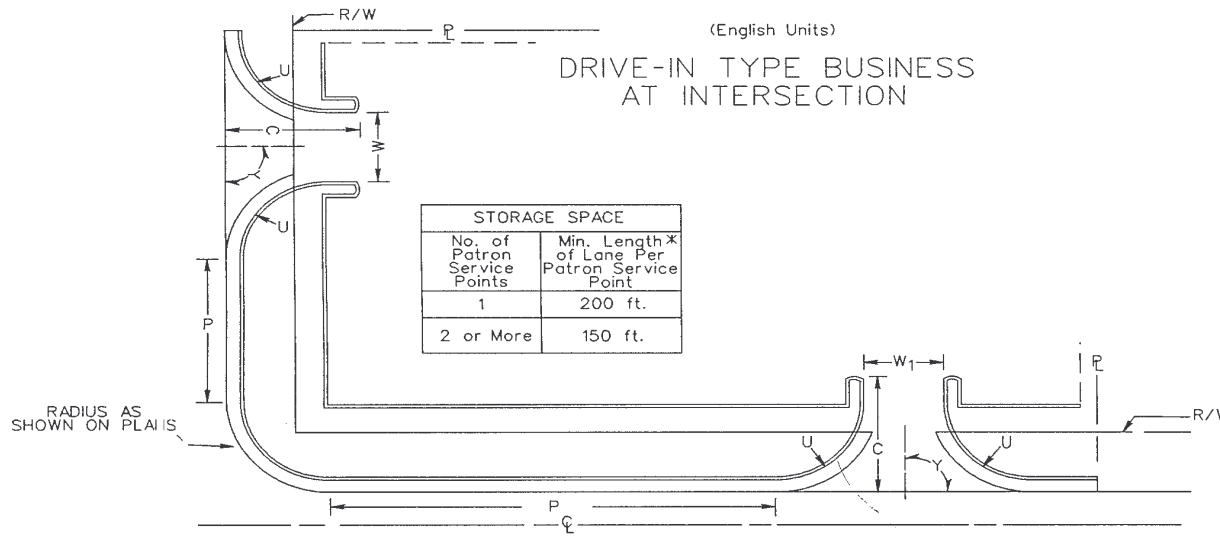

LETTER SYMBOL	DIMENSIONS
A	As determined by the Engineer
B	100' or greater
C	25' or greater. In developing areas where it is anticipated that the right turn lane will become a continuous thru lane in the future, an additional 12' is recommended.
G	12'
P	50' or greater (additional length will be required as directed by the Engineer if intersection is signalized or future signalization is anticipated.
U	12.5'-50'. The radii selected shall accommodate the anticipated type of vehicle usage. Larger radii should be considered by the Designer or may be required by the Engineer if larger vehicles are anticipated; however, in no case shall radius be less than 12.5'.
W	30'-40'
W ₁	14'-20' for one-way traffic
Y	60° - 90°

Minimum distance from gasoline pump to R/W line for Service Station	
Pump Island to Pavement Edge	Distance
Parallel	12 ft.
1° to 45°	20 ft.
46° to 90°	30 ft.

DRIVE-IN TYPE BUSINESS MID BLOCK WITH RIGHT TURN LANE AND TAPER

STORAGE SPACE	
No. of Patron Service Points	Min. Length* of Lane Per Patron Service Point
1	200 ft.
2 or More	150 ft.

* Length measured from nearest service point to highway.

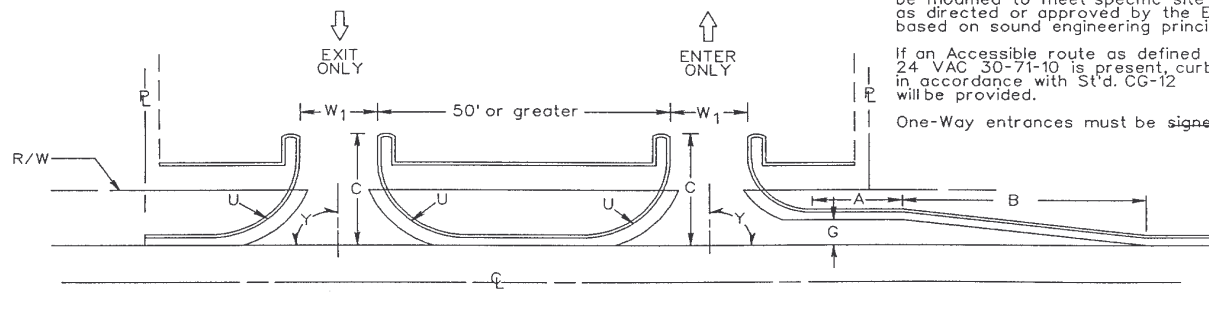

NOTES: Entrance details shown on this sheet may be modified to meet specific site requirements as directed or approved by the Engineer, when based on sound engineering principles.

If an Accessible route as defined in 24 VAC 30-71-10 is present, curb ramps in accordance with St'd. CG-12 will be provided.

One-Way entrances must be signed one-way.

Minimum Standards of Entrances to State Highways

COMMERCIAL ENTRANCE DESIGNS TO SERVE DRIVE-IN TYPE BUSINESSES SUCH AS DRIVE-IN BANKS, FAST FOOD RESTAURANTS, SERVICE STATIONS, AND CAR WASHES WITH ONE WAY TRAFFIC ENTERING AND/OR EXITING MAJOR HIGHWAY

LETTER SYMBOL	DIMENSIONS
A	As determined by the Engineer
B	30 m or greater
C	7.5 m or greater. In developing areas where it is anticipated that the right turn lane will become a continuous thru lane in the future, an additional 3.6 m is recommended.
G	3.6 m
P	15 m or greater (additional length will be required as directed by the Engineer if intersection is signalized or future signalization is anticipated.)
U	3.8 m-15 m. The radii selected shall accommodate the anticipated type of vehicle usage. Larger radii should be considered by the Designer or may be required by the Engineer if larger vehicles are anticipated; however, in no case shall radius be less than 3.8 m.
W	9 m-12 m
W ₁	4.2 m-6.0 m for one-way traffic
Y	60° - 90°

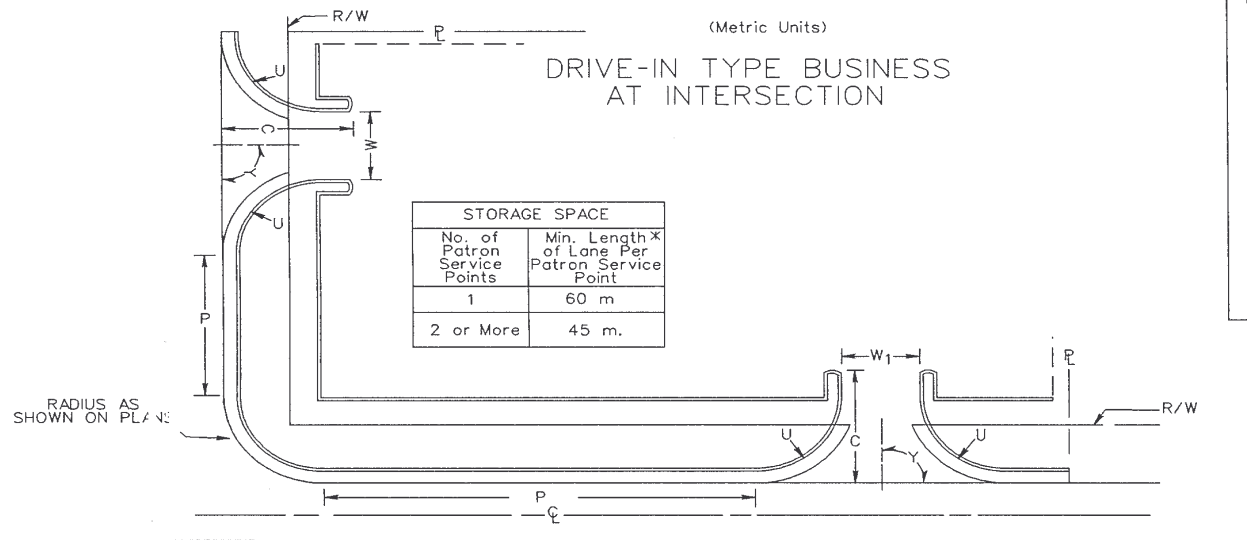

Minimum distance from gasoline pump to R/W line for Service Station	
Pump Island to Pavement Edge	Distance
Parallel	3.6 m
1° to 45°	6 m
45° to 90°	9 m

DRIVE-IN TYPE BUSINESS MID BLOCK WITH RIGHT TURN LANE AND TAPER

STORAGE SPACE	
No. of Patron Service Points	Min. Length* of Lane Per Patron Service Point
1	60 m
2 or More	45 m.

*Length measured from nearest service point to highway.

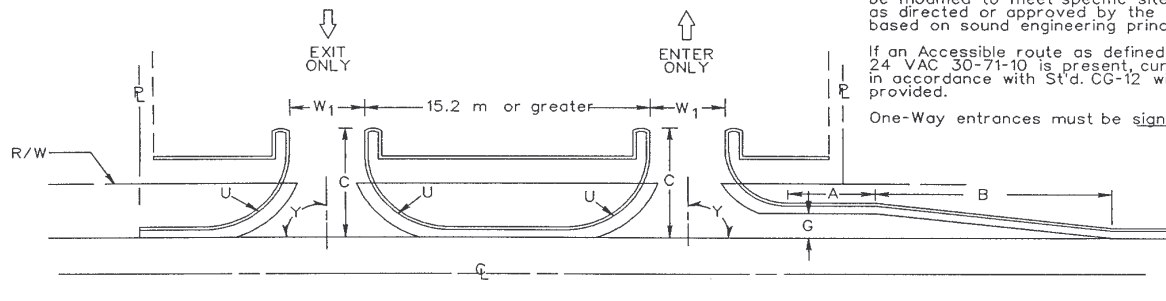

NOTES: Entrance details shown on this sheet may be modified to meet specific site requirements as directed or approved by the Engineer, when based on sound engineering principles.

If an Accessible route as defined in 24 VAC 30-71-10 is present, curb ramps in accordance with St'd. CG-12 will be provided.

Minimum Standards of Entrances to State Highways

STANDARD PRIVATE SUBDIVISION
ROAD/STREET ENTRANCE

(English Units)

Note:

Entrance details shown on this sheet may be modified to meet specific site requirements as directed or approved by the Engineer, when based on sound engineering principles.

All entrance grades shall start back of the shoulder line. If drainage is necessary, the ditch line may be moved back to provide at least 9" of cover over pipe, as shown at right.

Entrance shall be paved to a minimum width of 24'.

Entrance grades are to be smoothly tied into the roadway by rounding as necessary.

Minimum radius to be 25'. Increased radius may be required by local ordinance, Resident or District Traffic Engineer.

Entrances in fill to be same as above except location of culvert (when necessary).

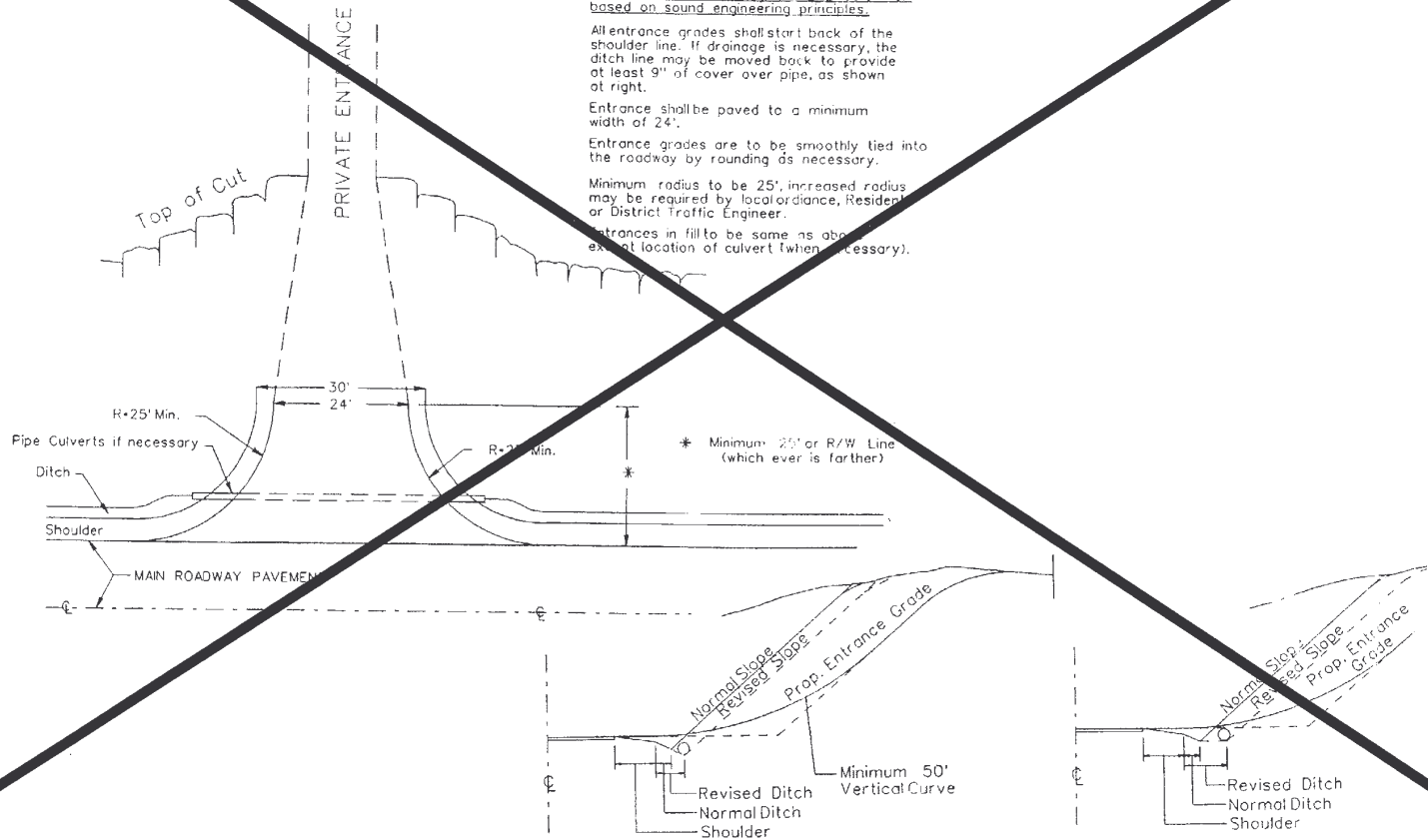

ALTERNATE METHODS FOR PLACING PIPES UNDER ENTRANCES

Minimum Standards of Entrances to State Highways

This illustration replaces the preceding deleted one

**STANDARD PRIVATE SUBDIVISION
ROAD/STREET ENTRANCE**

(English Units)

Note: Entrance details shown on this sheet may be modified to meet specific site requirements as directed or approved by the Engineer, when based on sound engineering principles.

All entrance grades shall start back of the shoulder line. If drainage is necessary, the ditch line may be moved back to provide at least 9" of cover over pipe, as shown at right.

Entrance shall be paved to a minimum width of 24'.

Entrance grades are to be smoothly tied into the roadway by rounding as necessary.

Minimum radius to be 25', increased radius may be required by local ordinance, Resident or District Traffic Engineer.

Entrances in fill to be same as above except location of culvert (when necessary).

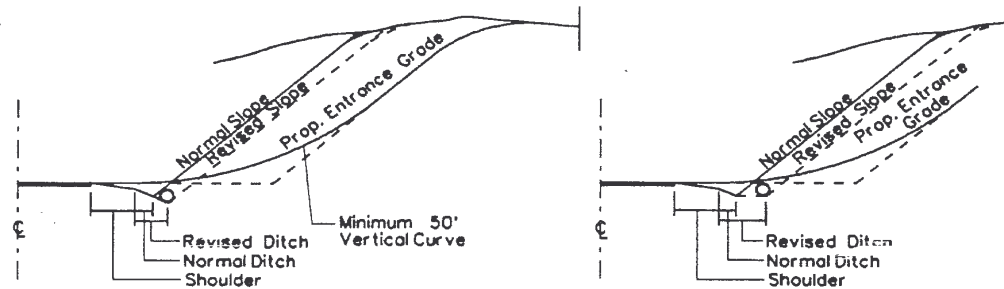
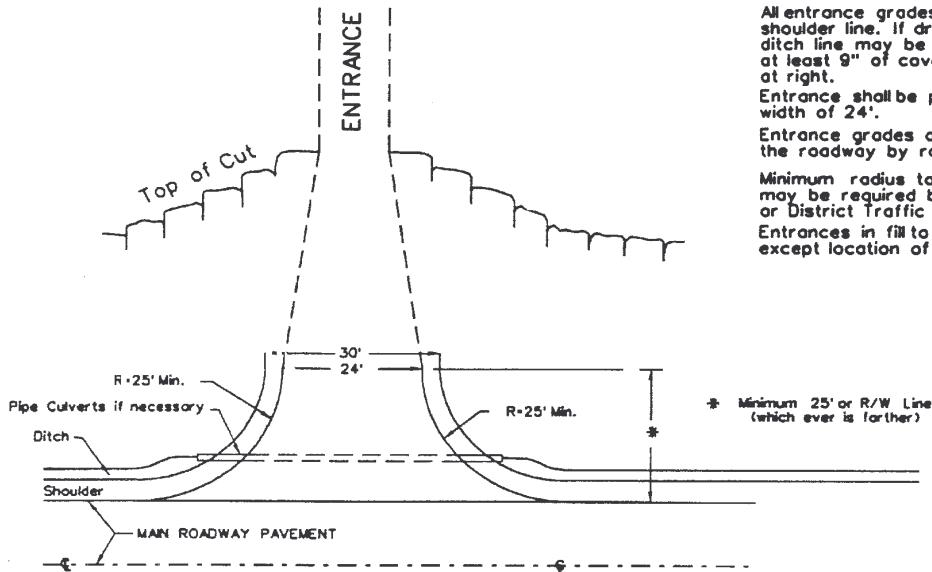

ALTERNATE METHODS FOR PLACING PIPES UNDER ENTRANCES

Minimum Standards of Entrances to State Highways

**STANDARD PRIVATE SUBDIVISION
ROAD/STREET ENTRANCE**

(Metric Units)

Note: Entrance details shown on this sheet may be modified to meet specific site requirements as directed or approved by the Engineer, when based on sound engineering principles.

All entrance grades shall start back of the shoulder line. If drainage is necessary, the ditch line may be moved back to provide at least 225 mm of cover over pipe, as shown at right.

Entrance shall be paved to a minimum width of 7.2 m.

Entrance grades are to be smoothly tied into the roadway by rounding as necessary.

Minimum radius to be 7.5 m, increased radius may be required by local ordinance, Resident or District Traffic Engineer.

Entrance fill to be same as above except location of culvert (when necessary).

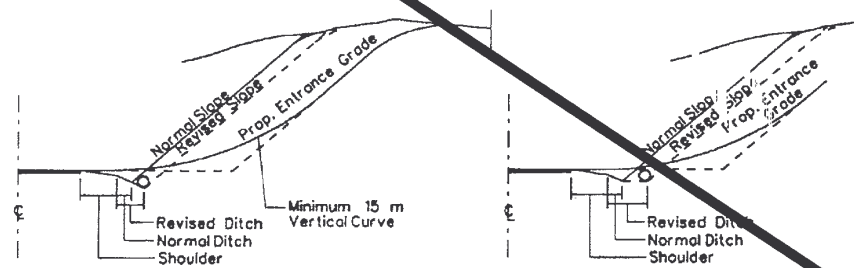
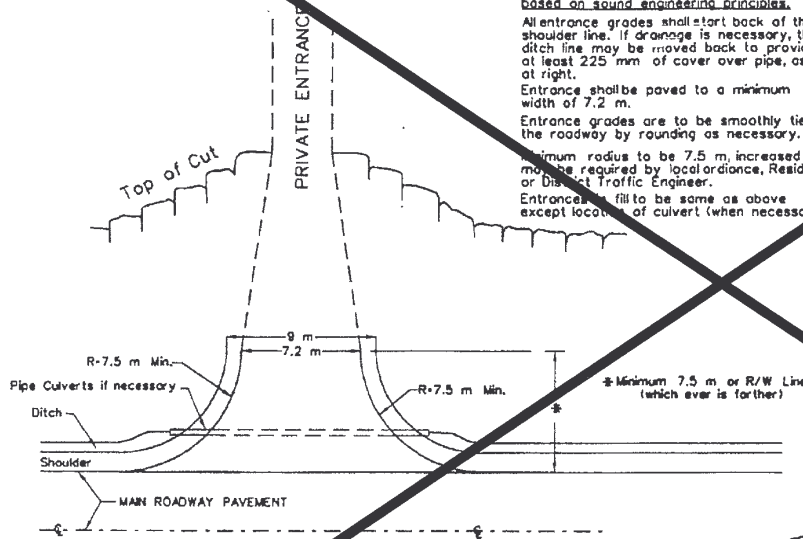

ALTERNATE METHODS FOR PLACING PIPES UNDER ENTRANCES

Minimum Standards of Entrances to State Highways

This illustration replaces the preceding deleted one

**STANDARD PRIVATE SUBDIVISION
ROAD/STREET ENTRANCE**

(Metric Units)

Note: Entrance details shown on this sheet may be modified to meet specific site requirements as directed or approved by the Engineer, when based on sound engineering principles.

All entrance grades shall start back of the shoulder line. If drainage is necessary, the ditch line may be moved back to provide at least 225 mm of cover over pipe, as shown at right.

Entrance shall be paved to a minimum width of 7.2 m.

Entrance grades are to be smoothly tied into the roadway by rounding as necessary.

Minimum radius to be 7.5 m, increased radius may be required by local ordinance, Resident or District Traffic Engineer.

Entrances in fill to be same as above except location of culvert (when necessary).

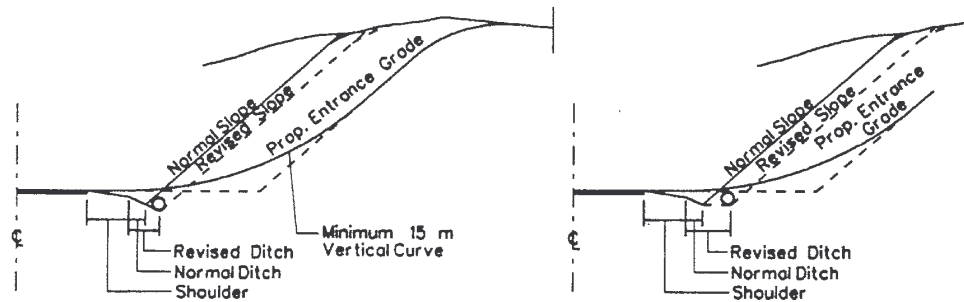
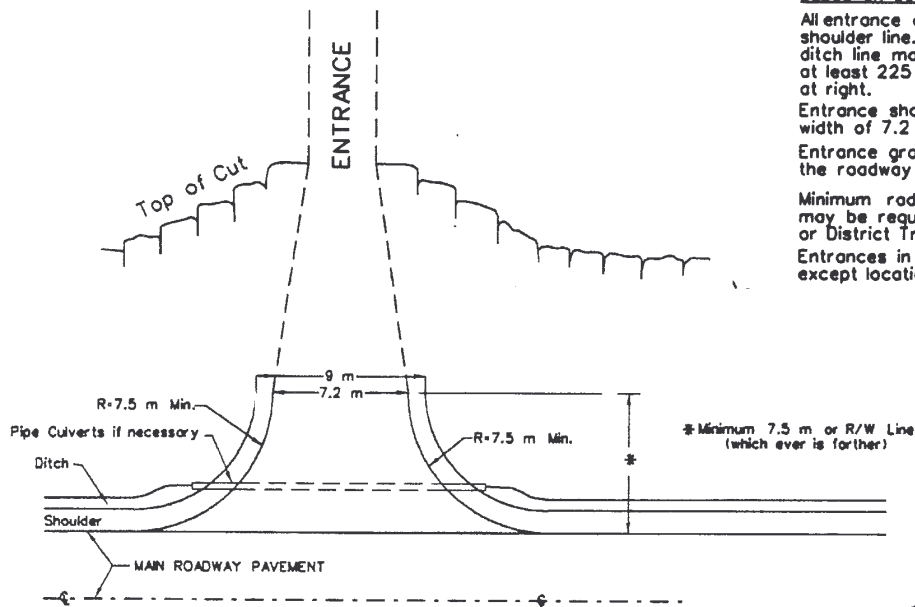

ALTERNATE METHODS FOR PLACING PIPES UNDER ENTRANCES

Minimum Standards of Entrances to State Highways

24 VAC 30-71-170. ~~Listing of Documents incorporated by reference.~~

~~Information pertaining to the availability and cost of any of these publications should be directed to the department's division indicated, by writing to the Virginia Department of Transportation, 1401 East Broad Street, Richmond, Virginia 23219.~~

- ~~1. Guidelines for Planting along Virginia's Roadways (1990), Environmental Division (VDOT)~~
- ~~2. 24 VAC 30-90-10 et seq., Subdivision Street Requirements (1996), Secondary Roads Division (VDOT)~~
- ~~3. 24 VAC 30-150-10 et seq., Land Use Permit Manual (1983), Maintenance Division (VDOT)~~
- ~~4. A Policy on Geometric Design of Highways and Streets (1994), Location and Design Division (VDOT)~~
- ~~5. Road and Bridge Standards, (revised April 1995) (English measurements), Road and Bridge Standards, (revised September 1997) (metric measurements), Location and Design Division (VDOT)~~
- ~~6. Pavement Design Guide for Subdivision and Secondary Roads in Virginia (1996), Materials Division (VDOT)~~
- ~~7. Road Design Manual, revised October 1996 (English measurements), Road Design Manual, (revised September 1996) (metric measurements), Location and Design Division (VDOT)~~
- ~~8. Road and Bridge Specifications (1994), (English measurements), Road and Bridge Specifications (1997) (metric measurements), Construction Division (VDOT)~~

Minimum Standards of Entrances to State Highways

A. The document entitled, "A Policy on Geometric Design of Highways and Streets," [1994 2001], American Association of State Highway & Transportation Officials, is incorporated by reference and made a part of this chapter.

This document may be obtained from the American Association of State Highway & Transportation Officials, 444 North Capitol Street N.W., Suite 249, Washington, DC 20001; E-Mail Address: info@aaashto.org.

[B. The Millennium (2000) edition of the Manual on Uniform Traffic Control Devices (MUTCD) (effective January 17, 2001) and revisions, including rulings thereto, is incorporated by reference and made a part of this chapter. It is available in electronic form on the Federal Highway Administration web site and can be found at <http://mutcd.fhwa.dot.gov>. It can also be ordered from: Superintendent of Documents, U.S. Government Printing Office, P. O. Box 371954, Pittsburgh, PA 15250-7954 (Stock # 050-001-00332-5 (MUTCD, errata and Revision 1).]

[B.C]. The following VDOT documents are incorporated by reference and made a part of this chapter:

[1. Chief engineer's memorandum entitled, "Guidance for Planting in the Clear Zone and Landscaping for VDOT Projects" dated October 31, 2000, Environmental Division;]

[2 1.] Road and Bridge Standards (English measurements), effective February 2001, Location and Design Division;

Minimum Standards of Entrances to State Highways

[3 2.] Road and Bridge Standards (metric measurements), effective January 1997,

Location and Design Division;

[4 3.] Pavement Design Guide for Subdivision and Secondary Roads in Virginia,

effective September 2000, Materials Division;

[5 4.] Road Design Manual (English and metric measurements), effective July 1998,

Location and Design Division

[6 5.] Road and Bridge Specifications (English measurements), effective 2002,

[Construction Scheduling and Contract Development] Division;

[7 6.] Road and Bridge Specifications (metric measurements), effective 1997,

[Construction Scheduling and Contract Development] Division.

The documents identified in this subsection may be obtained by writing to the attention of the division noted by each document at the Virginia Department of Transportation, 1401 E. Broad Street, Richmond, Virginia 23219, or via the Internet at <http://virginiadot.org/business/default.asp>.

C. VDOT regulations referenced throughout this chapter may be obtained from the Virginia Department of Transportation, 1401 E. Broad Street, Richmond, Virginia 23219, or by accessing the Virginia Administrative Code website at <http://leg1.state.va.us/000/reg/TOC24030.HTM>.

Minimum Standards of Entrances to State Highways

FORMS

Entrance Permit Application, MP-253, 1989 (rev. 3/02).

Land Use Permit Surety Bond, MP-20 (rev. 4/99)

[GUIDANCE DOCUMENT

Instructional and Informational Memorandum (IIM) LD-227.1, dated January 15, 2003]

CERTIFICATION

I certify that this regulation is full, true, and correctly dated.

Deputy Commissioner

Claude D. Garver, Jr.
Deputy Commissioner
Virginia Department of Transportation

Date