



★ VIRGINIA ★
STATE BOARD *of* ELECTIONS

BOARD MEETING

Tuesday, August 06, 2019

Senate Room 3

Virginia State Capitol

Richmond, VA

1:00 P.M.

SBE Board Working Papers



**STATE BOARD OF ELECTIONS
AGENDA**

DATE: Tuesday, August 06, 2019

LOCATION: Senate Room 3

Virginia State Capitol

Richmond, VA

TIME: 1:00 PM

I. CALL TO ORDER

Robert Brink, Chairman

II. APPROVAL OF MINUTES

Jamilah LeCruise, Secretary

a. June 24, 2019

b. June 28, 2019

c. July 11, 2019

d. July 19, 2019

*Christopher E. Piper
Commissioner*

III. COMMISSIONER'S REPORT

*Eugene Burton
Voting Technology
Coordinator*

IV. ES &S EVS 6.0.4.0 Certification

*Samantha Buckley
Policy Analyst*

**V. 2020 Independent & 3rd Party
Presidential Candidate Petitions**

*Arielle A. Schneider
Policy Analyst*

VI. CAMPAIGN FINANCE

A. Repeal of 1 VAC 20-90-20

B. Stand by Your Ad

1. Corbo for School Board (CC-19-00391)

2. David F. Williams

3. Donald Smith for Sheriff (CC-15-00114)

4. Dwayne T. Wade (CC-19-00772)

5. Galvin for Delegate (CC-19-00330)

6. Gwen for Office (CC-19-00683)

7. Elect Kenya Savage (CC-19-00294)

8. Friends of Levin White 2019 (CC-18-00282)

9. Lloyd Banks, Jr.

10. Patrick "Pat" Saylor

11. Friends of Rich Breeden LLC (CC-18-00577)

12. Friends of Scott Wyatt (CC-19-00177)

13. Virginia Constitutional Conservatives (PAC-17-00698)

VII. PUBLIC COMMENT

VIII. ADJOURNMENT

NOTE: All materials provided to the Board are available for public inspection under the Virginia Freedom of Information Act upon request.



★ VIRGINIA ★
STATE BOARD *of* ELECTIONS

Approval of Minutes

BOARD WORKING PAPERS
State Board of Elections

1 The State Board of Elections ("the Board") meeting was held Monday, June 24, 2019, in
2 the DoubleTree by Hilton Hotel Richmond-Midlothian, Parlor G/H 1021 Koger Center Blvd,
3 Richmond, VA 23235. In attendance: Robert Brink, Chairman, John O'Bannon, Vice Chairman
4 and Jamilah LeCruise, Secretary, represented the State Board of Elections ("the Board").
5 Christopher E. "Chris" Piper, Commissioner, and Jessica Bowman, Deputy Commissioner
6 represented the Department of Elections ("ELECT"). Alex West represented the Office of the
7 Attorney General ("OAG"). Chairman Brink called the meeting to order at 5:30 P.M.

8 The first order of business was for the Board to approve the May 14, 2019 Board meeting
9 minutes, presented by Secretary LeCruise. The Vice Chair moved that the Board approve the
10 minutes from the May 14, 2019 Board meeting. Chairman Brink seconded the motion, and the
11 motion passed unanimously.

12 The next order of business was the Commissioner's report, presented by Commissioner
13 Piper. The Commissioner informed the Board that the June Primary election was very successful.
14 Commissioner Piper stated that one incident occurred in the City of Roanoke, but the issue was
15 quickly fixed by 9:00 A.M. that morning. The Commissioner informed the Board that ELECT
16 has posted the new positions that were authorized by the General Assembly. Commissioner Piper
17 stated that ELECT has also contracted a consultant to help with risk-limiting audits. The
18 Commissioner explained to the Board that it is a Virginia Code requirement that ELECT
19 performs post-election audits and risk limiting audits. Commissioner Piper stated that the
20 consultant has reached out to a few localities and will be sending risk-limiting audit pilots over
21 the next few months.

22 The next order of business was the Stand by Your Ad hearing, hearing presented by
23 Arielle A. Schneider, Policy Analyst. Ms. Schneider explained to the Board that she would be
24 presenting one print media complaint against Joe Morrissey. She briefly informed the Board of
25 the different definitions that pertained to the complaint being discussed, including *advertisement*,
26 *candidate*, *express advocacy* and *expenditure*. She also reviewed the Schedule of Penalties to be
27 assigned to print media advertisements in violation of § 24.2-955 et seq. before showing the
28 three videos that were displayed via the eight Facebook ad promotions purchased by Mr.
29 Morrissey between March 10, 2019 and April 24, 2019, when the complaint was submitted to the

30 Department of Elections for review. *This report is in the Working Papers for the June 24, 2019*
31 *meeting*. Chairman Brink then provided an opportunity for Mr. Morrissey to address the Board.

32 After Mr. Morrissey's comments, Ms. Schneider addressed each of the eight Facebook
33 promotions individually and noted for the Board that the disclosure automatically posted by
34 Facebook "Paid for by Joe Morrissey" does not satisfy the disclosure requirements provided in
35 the Code of Virginia § 24.2-956, which requires that "an advertisement sponsored by a candidate
36 or a candidate campaign committee that makes reference to any other clearly identified candidate
37 who is not sponsoring the advertisement, the sponsor shall state whether it is authorized by the
38 candidate not sponsoring the advertisement. The visual legend in the advertisement shall state
39 either "Authorized by [Name of candidate], candidate for [Name of office]" or "Not authorized
40 by any other candidate." Ms. Schneider recommended the Board find Joe Morrissey in violation
41 of eight print media advertisements and assess an \$800 penalty or, in the event that the Board
42 found that the first video did not constitute express advocacy, that the Board find Joe Morrissey
43 in violation of six print media advertisements and assess a \$600 penalty.

44 The Board then considered whether the first of the three videos constituted express
45 advocacy, and determined by consensus that the first video did not but that the remaining two did
46 expressly advocate for the election of Joe Morrissey. Secretary LeCruise suggested the Board
47 adopt the latter recommendation of Ms. Schneider, and *moved that the State Board of Elections*
48 *find Joe Morrissey in violation of six print media advertisements and assess a \$600 penalty.*
49 Vice Chair O'Bannon seconded the motion and the motion was approved unanimously.

50 Chairman Brink opened the floor to public comment. Jeff Mitchell and Jerry Kilgore
51 spoke on behalf of Delegate Terry Kilgore. Jeff Mitchell spoke to the Board regarding the
52 certification of Delegate Terry Kilgore as the Republican nominee in the 1st Delegate District, He
53 presented to the Board several affidavits of individuals who participated in the nominating
54 convention and asked the Board to certify Terry Kilgore as the Republican candidate for the 1st
55 district. Commissioner Piper recommended that the Board seek legal advice from the Office of
56 the Attorney General and inform the parties of OAG's guidance.

57 The next item on the agenda was the Revised Third Party Registration Guidelines,
58 presented by Garry Ellis, NVRA/Voter Registration Coordinator. Mr. Ellis presented the Board

59 with a revision to the Third Party Voter Registration Drive Training, a requirement under the
60 Code of Virginia §24.2-416.6. *This report is in the Working Papers for the June 24, 2019*
61 *meeting*. Mr. Ellis advised that the revision would be on page 42 of the working papers, showing
62 the amended Voter Registration Application. Vice Chair O'Bannon *moved to adopt the proposed*
63 *201-2020 3rd Party Voter Drive Training*. Secretary LeCruise seconded the motion, and the
64 motion passed unanimously.

65 The next item on the agenda was the Simultaneous Recount Instructions, presented by
66 Samantha Buckley, Policy Analyst. *This report is in the Working Papers for the June 24, 2019*
67 *meeting*. Ms. Buckley explained to the Board that a Simultaneous Recount occurs when a judge
68 orders recounts of multiple races on a ballot. She stated that bill HB2625 required the Board to
69 create instructions in the event of-a Simultaneous Recount-Secretary LeCruise *moved to adopt*
70 *the instructions and documents for Simultaneous Recount*. Vice Chair O'Bannon seconded the
71 motion, and the motion passed unanimously.

72 The next item on the agenda was the Revised Ballot Standards, presented by Samantha
73 Buckley, Policy Analyst. *This report is in the Working Papers for the June 24, 2019 meeting*.
74 Ms. Buckley explained to the Board that two bills passed during the 2019 Session SB1577 and
75 HB2148 -- required a revision in the Ballot Standards. Vice Chair O'Bannon *moved to approve*
76 *the amendments to the Ballot Standards*. Secretary LeCruise seconded the motion, and the
77 motion passed unanimously.

78 The next item on the agenda was the Presidential Primary Candidate/Party Schedule,
79 presented by David Nichols, Director of Elections Services. *This report is in the Working Papers*
80 *for the June 24, 2019 meeting*. Mr. Nichols stated that the law requires the State Board to adopt
81 deadlines, a schedule for notices, and filing deadlines for Presidential Primary Candidates. He
82 informed the Board that during the updating of the 2015 approved schedule ELECT consulted
83 with both political parties to ensure the deadlines were reasonable and the information
84 accessible. Chairman Brink asked if the provision included the withdrawal of candidates. Mr.
85 Nichols stated that the new version provides for the withdrawal of candidates, with a deadline set
86 ~~for~~ as late as possible for candidates to withdraw from a ballot. He stated that petitions are filed
87 by December 12 and a candidate can file a withdrawal by December 18th. Secretary LeCruise

88 moved to adopt the 2020 Presidential Primary candidate and party bulletin titled *How to Run for*
89 *Office for Candidates and Party Representatives*. Vice Chair O'Bannon seconded the motion,
90 and the motion passed unanimously.

91 The next item on the agenda was the Presidential Candidate Form, presented by David
92 Nichols, Director of Elections Services. *This report is in the Working Papers for the June 24,*
93 *2019 meeting*. Mr. Nichols informed the Board that Virginia Code section 24.2-545 requires
94 candidates in a presidential primary to file petitions signed by at least 5,000 qualified voters with
95 a minimum of 200 from each Congressional district in order to qualify to have their name printed
96 on the ballot. [He explained that for the petitions, they would be discussing the Short and long
97 Petition of Qualified Voters for Presidential Primary.] He then informed the Board that in the
98 past the SBE-505/520 included a Consent of Presidential Candidate section that was not required
99 by law. Mr. Nichols explained that the new form does not have this section. Mr. Nichols stated
100 that the only change made to the Petition Forms was the dates. Chairman Brink asked whether, if
101 a party had 25 candidates, it could submit additional forms. Mr. Nichols stated that the party
102 representative would send an email with a list of all the candidates. Vice Chair O'Bannon *moved*
103 *to adopt both the proposed short and long forms of the Petition of Qualified Voters for*
104 *Presidential Primary and the proposed Declaration of Candidacy for President of the United*
105 *States*. Secretary LeCruise seconded the motion, and the motion passed unanimously.

106 The next item on the agenda was the Certification of Elections – June 11, 2019 primary,
107 presented by David Nichols, Director of Elections Services. Mr. Nichols provided a memo with
108 the names and the winners for each primary. *This report is in the Working Papers for the June*
109 *24, 2019 meeting*. Mr. Nichols informed the Board that they would be able to sign the abstract
110 after the meeting. Secretary LeCruise moved that the Board certify the results of the June 11,
111 2019, Democratic and Republican Primary Elections as presented and declare the winners of
112 each primary to be that party's nominee for the November 5, 2019, General Election. Vice Chair
113 O'Bannon seconded the motion, and the motion passed unanimously.

114 The next item on the agenda is the Party Ballot Order Drawing, presented by David
115 Nichols, Director of Elections Services. Mr. Nichols explained to the Board that the ballot

116 drawing would only be for the order of the parties for the November election. This will only
117 include the Republican and Democratic parties.

118 The position order on the ballot will be:

119 Republican

120 Democratic.

121 Chairman Brink *moved that the Board certify the determination by lot of the ballot order for the*
122 *general and special elections being held November 5, 2019, and all other special elections*
123 *between today and November 5, 2019.* Vice Chair O'Bannon seconded the motion, and the
124 motion passed unanimously.

125 Chairman Brink announced that the Board would go into closed session. Vice Chair
126 O'Bannon *moved that the Board go into closed session for the purpose of consultation with legal*
127 *counsel and briefings by staff members or consultants for the purpose of consultation with legal*
128 *counsel concerning the 1st and 97th House District nomination, as authorized by Section 2.2-*
129 *3711(A)(8) of the Code of Virginia. In accordance with Virginia Code Section 2.2-3712(F), Alex*
130 *West from the Office of the Attorney General, as well as Christopher Piper, Commissioner of*
131 *Elections, and Jessica Bowman, Deputy Commissioner of Elections will attend the closed session*
132 *because their presence will reasonably aid the Board in its consideration of the subject of the*
133 *meeting.* Secretary LeCruise seconded the motion, and the motion passed unanimously.

134 At 7:29 P.M. Secretary LeCruise *moved to reconvene in open session, and take a roll call*
135 *vote certifying that to the best of each member's knowledge (i) only such public business matters*
136 *lawfully exempted from open meeting requirements under this chapter and (ii) only such public*
137 *business matters as were identified in the motion by which the closed meeting was concerned*
138 *were heard, discussed, or considered.* A roll call vote was taken:

139 Secretary LeCruise – aye

140 Vice Chair O'Bannon – aye

141 Chairman Brink – aye

142 Chairman Brink stated that the Board is seeking the advice of counsel on the 1st district
143 nomination, and a response should be provided by Friday, June 28, 2019. Vice Chair *moved to*
144 *adjourn the meeting*. Secretary LeCruise seconded the motion, the motion passed unanimously.
145 The meeting adjourned at approximately 7:31 P.M.

146

147 _____

148 Secretary

149 _____

150 Chairman

151 _____

152 Vice Chairman

1 The Friday, June 28, 2019 State Board of Elections meeting was held in the Martha
2 Brissette Conference Room of the Washington Building in Richmond, Virginia. In attendance:
3 Robert Brink, Chairman, and John O’Bannon, Vice Chairman represented the State Board of
4 Elections (“the Board”). Christopher E. “Chris” Piper, Commissioner represented the
5 Department of Elections (“ELECT”). Heather Hays Lockerman represented the Office of the
6 Attorney General (“OAG”). Jamilah LeCruise, Secretary participated electronically. Chairman
7 Brink called the meeting to order at 1:05 P.M.

8 Vice Chairman O’Bannon moved *that the Board go into closed session for the purpose of*
9 *consultation with legal counsel and briefings by staff members or consultants for the purpose of*
10 *consultation with legal counsel concerning the 1st and 30th House District nomination, as*
11 *authorized by Section 2.2-3711(A)(8) of the Code of Virginia. In accordance with Virginia Code*
12 *Section 2.2-3712(F), Heather Hays Lockerman from the Office of the Attorney General, as well*
13 *as Christopher Piper, Commissioner of Elections, James M. Heo, Confidential Policy Advisor*
14 *and David Nichols, Director of Election Services will attend the closed session because their*
15 *presence will reasonably aid the Board in its consideration of the subject of the meeting.*
16 Chairman Brink seconded the motion, and the motion passed unanimously.

17 Vice Chairman O’Bannon moved *to reconvene in open session, and take a roll call vote*
18 *certifying that to the best of each member’s knowledge (i) only such public business matters*
19 *lawfully exempted from open meeting requirements under this chapter and (ii) only such public*
20 *business matters as were identified in the motion by which the closed meeting was concerned*
21 *were heard, discussed, or considered.* Secretary LeCruise seconded the motion, and the motion
22 passed unanimously. A roll call vote was taken:

23 Secretary LeCruise – aye

24 Vice Chair O’Bannon – aye

25 Chairman Brink – aye

26 Vice Chair O’Bannon moved *that the Board accept the ELECT-511 form certifying the*
27 *Republican nominee for the 1st House of Delegates District, and direct the Commissioner to*
28 *develop a policy to be approved by the Board on how to handle administrative errors with*

29 *regard to accessing the ballot.* Secretary LeCruise seconded the motion, and the motion passed
30 unanimously.

31 Commissioner Piper stated that he was directed by the Board to get clarification on the
32 statement submitted by the Secretary of the State Central Committee Republican party regarding
33 the 97th House District. The Commissioner stated that he received a signed letter from Chairman
34 Wilson of the Republican Party of Virginia. *This report is in the Working Papers for the June 28,*
35 *2019 meeting.* Commissioner Piper stated that the Board is able to move forward in regards to
36 the 97th House District.

37 Vice Chair O'Bannon *moved to adjourn the Board.* Secretary LeCruise seconded the motion, the
38 motion passed unanimously. The meeting adjourned at approximately 1:53 P.M.

39

40 _____

41 Secretary

42 _____

43 Chairman

44 _____

45 Vice Chairman

1
2
3
4
5
6
7
8
9
10
11
12
13
14
15
16
17
18
19
20
21
22
23
24
25
26
27
28

The Thursday, July 11, 2019, State Board of Elections meeting was held in the Martha Brissette Conference Room of the Washington Building in Richmond, Virginia. In attendance: Robert Brink, Chairman, John O’Bannon, Vice Chairman, and Jamilah LeCruise, Secretary, represented the State Board of Elections (“the Board”). Christopher E. “Chris” Piper, Commissioner, Jessica Bowman, Deputy Commissioner, represented the Department of Elections (“ELECT”). Flora Hezel represented the Office of the Attorney General, and Heather Hays Lockerman represented the Office of the Attorney General (“OAG”) participated electronically. Chairman Brink called the meeting to order at 2:00 P.M.

The first item on the agenda was the Petition Appeal for Jasmine Moawad, presented by Samantha Buckley, Policy Analyst. Ms. Buckley explained to the Board that a candidate disqualified due to an insufficient number of qualified petition signatures can appeal the disqualification. One of the requirements to appeal petition signatures is to provide ELECT with a list of rejected signatures to be reviewed. If a candidate does not provide a sufficient number of rejected signatures for reconsideration to ELECT by the deadline, the candidate disqualification is final. Ms. Buckley explained that ELECT provides a letter to inform the candidate of the disqualification, the reason for the disqualification and instructions on how to appeal the disqualification.

Ms. Buckley informed the Board that Ms. Moawad did not provide the list of rejected signatures to be reviewed, so the disqualification is final, and no appeal will be heard.

The next item on the agenda was the Petition Appeal for Elliot Harding presented by Samantha Buckley, Policy Analyst. Ms. Buckley stated that Mr. Harding is appealing his disqualification due to an insufficient number of qualified petition signatures. *Please refer to the July 11, 2019 Memorandum: Appeal of Insufficient Petition Signatures by Elliot Harding located in the Working Papers.* She explained that Mr. Harding has 247/250 validated signatures, which means that his signatures are deficient by three. If the Board qualifies three signatures, the qualifications to place his name on the November 2019 ballot for Senate of Virginia, 25th district will be satisfied.

29 Ms. Buckley presented the first signature for the Board to consider. Vice Chair O'Bannon
30 *motion to validate this signature and count this signature towards the candidate's total number*
31 *of petition signatures due to the reasoning provided by the candidate.* Chairman Brink seconded
32 the motion, and the motion passed unanimously.

33 Ms. Buckley presented the second signature for the Board to consider. A registration
34 deadline was in effect due to the June 11, 2019 primary election. If the candidate was gathering
35 petitions in a locality without a primary, no registration deadline would apply and the signer's
36 voter registration application would have been processed and the signature counted. Secretary
37 LeCruise *moved to validate this signature and count this signature towards the candidate's total*
38 *number of petition signatures due to the reasoning provided by the candidate.* Vice Chair
39 O'Bannon seconded the motion, and the motion passed unanimously.

40 Ms. Buckley presented the third signature for the Board to consider. Vice Chair
41 O'Bannon *moved to validate this signature and count this signature towards the candidate's*
42 *total number of petition signatures due to the reasoning provided by the candidate.* Secretary
43 LeCruise seconded the motion, and the motion passed unanimously.

44 The next item on the agenda was the Determination of Candidate Qualification presented
45 by Dave Nichols, Elections Service Manager. Mr. Nichols stated that two candidate qualification
46 issues would be presented to the Board for consideration. *Please refer to the July 11, 2019*
47 *Memorandum: Determination of Candidate Qualification located in the Working Papers.*

48 Mr. Nichols informed the Board that a local General Registrar contacted ELECT about
49 the lack of a Republican candidate for the House of Delegates 30th District. Mr. Nichols stated
50 that after review, ELECT determined that a Party Certification of Non-Primary Candidate form
51 (ELECT-511) for Republican candidate for the House of Delegates 30th District had not been
52 received. Further, ELECT confirmed it had not received any candidate paperwork, either the
53 Certificate of Candidate Qualification (SBE-501) or Statement of Economic Interest (SOEI)
54 from any Republican candidate seeking to run for the House of Delegates 30th District.

55 Mr. Nichols informed the Board that after publicly posting a list of candidates for
56 Virginia House of Delegates, ELECT was contacted about the absence of a Democratic
57 candidate for the House of Delegates 76th District. After review, ELECT confirmed that no

58 Party Certification of Non- Primary Candidate form (ELECT-511) was received, but that both a
59 candidate qualification form (SBE-501) and SOEI was submitted. *Please refer to the July 11,*
60 *2019 Memorandum: Determination of Candidate Qualification located in the Working Papers.*

61 Chairman Brink confirmed that it was the position of both candidates that, due to an
62 internal party administrative error, ELECT did not receive the proper certification from the
63 district's legislative district chair. The Chairman asked whether the Department had received a
64 Certificate of Candidate Qualification or the Statement of Economic Interest for any Republican
65 candidate for House District 30. Mr. Nichols stated that when the General Registrar contacted
66 ELECT, the candidate had not yet provided the documents but since then the candidate has
67 submitted the documents to ELECT staff. Chairman Brink asked Mr. Nichols to explain the
68 function of the Certificate of Candidate Qualification (SBE-501). Mr. Nichols explained that the
69 Certificate of Candidate Qualification (SBE-501) is required by the Code of Virginia 24.2-501,
70 which states "[i]t shall be a requirement of candidacy for any office of the Commonwealth, or of
71 its governmental units, that a person must file a written statement under oath, on a form
72 prescribed by the State Board, that he is qualified to vote for and hold the office for which he is a
73 candidate." The SBE-501 also collects additional information about the prospective candidate,
74 including the candidate's voter registration address and information about the office sought.

75 The Commissioner explained that Virginia Code 24.2-503 grants the State Board of
76 Elections the authority to "grant an extension of any deadline for filing either or both written
77 statements and shall notify all candidates who have not filed their statements of the extension.
78 Any extension shall be granted for a fixed period of time of ten days from the date of the mailing
79 of the notice for the extension."

80 Christopher Woodfin addressed the Board on behalf of Nicholas Freitas, accompanied by
81 Chairman Jim Smith of the Madison County Republican Party and Chairman Bruce Kay, the
82 Republican Legislative District Chair for the 30th District. Mr. Woodfin said "both of the
83 gentlemen here today can contest Nick Freitas was the only candidate that filed both filling
84 forms and fee by the day requested which was March 8th. On the morning of March 9th Chairman
85 Kay sent an email to Republican party of Virginia and copied all committee members on it.
86 Where he basically said Nick Freitas was the only candidate that file for nominations and
87 therefore we are pursuant to the call he is certified as the nominee and the convention is

88 cancelled.” Mr. Woodfin added, “Then we move on to the actually filing of the form 511,
89 following that letter you will see in there two items, one is an affidavit from Mr. Kay and he is
90 available to answer questions, stating that he did email that certification form in on May 7th,
91 following the affidavit is a copy of the certification form with a handwritten note from Mr. Kay
92 that he wrote for himself when he saved it in his file that he filed it to Mr. Paul Stenbjorn.” Mr.
93 Woodfin stated that Mr. Kay was the Chairman two years ago, and followed his same process by
94 emailing it to Mr. Stenbjorn, not knowing Mr. Stenbjorn was no longer with ELECT. Mr.
95 Woodfin requested that the Board accept the SBE-501 and ELECT -511 form and allow
96 Nicholas Freitas’s name to be printed on the ballot as the Republican nominee for the 30th
97 District.

98 Chairman Brink asked Mr. Woodfin when Mr. Freitas filed the SBE-501 form. Mr.
99 Woodfin advised that he filed it the day before the Kilgore meeting. Secretary LeCruise asked
100 why was Mr. Freitas under the impression that he mailed his form in. Mr. Woodfin stated that
101 normally Mr. Freitas would mail his form in due to living in Culpeper, but this time Mr.
102 Woodfin told Mr. Freitas to hand deliver the form. Chairman Brink asked ELECT, when and
103 how was the extension granted to file. Mr. Nichols informed the Board that the extension was
104 granted on June 14th. He informed the Board that on June 14th ELECT sent out a memo along
105 with an extension letter from the Commissioner to all candidates that had not filed the Statement
106 of Economic Interest form or the SBE-501 form. Chairman Brink asked Mr. Nichols about the
107 steps taken to provide notice to candidates of the filing requirements. Mr. Nichols stated that in
108 past years ELECT has created a candidate bulletin, containing what and when the information
109 needed to be filed. He informed the Board that this year ELECT removed the party information
110 from the candidate bulletin and created a separate party bulletin. Mr. Nichols added that ELECT
111 also provides information to the state parties of important deadlines. Commissioner Piper
112 informed the Board that ELECT is in constant contact with the state parties throughout the entire
113 process.

114 John Burcon then addressed the Board on behalf of Mr. Clinton Jenkins. Mr. Burcon
115 requested that the Board accept the ELECT-511 form, submitted by the Chairwoman Rinaldi of
116 the Democratic nominating committee. Mr. Burcon informed the Board that on May 13th
117 Chairwoman Rinaldi emailed Leslie Williams of the Virginia Department of Election containing

118 the candidate certification for Clinton Jenkins. Mr. Burcon stated that after reviewing the email,
119 he noticed that Ms. Rinaldi emailed williams.leslie@elections.virginia.gov instead of
120 leslie.williams@elections.virginia.gov. Secretary LeCruise asked Mr. Burcon, when did Ms.
121 Rinaldi realize that she sent the information to the incorrect email. Mr. Burcon stated that Ms.
122 Rinaldi was not aware of the error until July 1st.

123 At 2:37 P.M. Chairman Brink announced that the Board would go into closed session.
124 Vice Chair O'Bannon *moved that the Board go into closed session for the purpose of*
125 *consultation with legal counsel and briefings by staff members or consultants for the purpose of*
126 *receiving legal advice concerning the 76th and 30th House District nomination, as authorized by*
127 *Section 2.2-3711(A)(8) of the Code of Virginia. In accordance with Virginia Code Section 2.2-*
128 *3712(F), Flora Hezel and Heather Hays Lockerman from the Office of the Attorney General, as*
129 *well as Christopher Piper, Commissioner of Elections, and Jessica Bowman, Deputy*
130 *Commissioner of Elections will attend the closed session because their presence will reasonably*
131 *aid the Board in its consideration of the subject of the meeting.* Secretary LeCruise seconded the
132 motion, and the motion passed unanimously.

133 At 3:28 P.M. Secretary LeCruise *moved to reconvene in open session, and take a roll call*
134 *vote certifying that to the best of each member's knowledge (i) only such public business matters*
135 *lawfully exempted from open meeting requirements under this chapter and (ii) only such public*
136 *business matters as were identified in the motion by which the closed meeting was concerned*
137 *were heard, discussed, or considered.* Vice Chair O'Bannon seconded the motion, and the
138 motion passed unanimously. A roll call vote was taken:

139 Secretary LeCruise – aye

140 Vice Chair O'Bannon – aye

141 Chairman Brink – aye

142 Vice Chair O'Bannon prefaced a motion by stating that the Board had considered the
143 request that Terry Kilgore be accepted as the nominee of the Republican Party of the First House
144 of Delegates Legislative District. After consideration of the important constitutional rights
145 associated with a party's access to the ballot and the requirements imposed by Virginia Code §
146 24.2-511(A) that the District Party Chairman certify to the State Board of Elections the name of

147 the party's General Assembly candidate nominated by his party by a method other than a
148 primary and the date of such nomination, as well as the evidence that establishes that the party
149 made reasonable attempts to comply with deadlines of the submission process:

- 150 1. The affidavit of Robert B. Hines, II, Chairman of the Republican Party of the First House
151 Legislative District;
- 152 2. The affidavits of Douglas M. Pillion, Pat Davis, Jr., and Terry L. Sivert, voters in
153 Virginia's First House of Delegates Legislative District and attendees at the mass meeting
154 of the Republican Party on April 25, 2019; and
- 155 3. The affidavit of attorney J. Jasen Eige.

156 Vice Chair O'Bannon then *moved that the Board accept Terry Kilgore as the Republican*
157 *nominee for the 1st House of Delegates District and that his name be placed on the ballot for the*
158 *2019 General Election.* Secretary LeCruise seconded the motion, and the motion passed
159 unanimously.

160 Secretary LeCruise stated that the Board would vote on a motion regarding the request
161 that Clinton L. Jenkins be accepted as the nominee of the 76th House of Delegates Democratic
162 Nominating Committee. In consideration of the important constitutional rights associated with a
163 party's access to the ballot and the requirements imposed by Virginia Code § 24.2-511(A) that
164 the District Party Chairman certify to the State Board of Elections the name of the party's
165 General Assembly candidate nominated by his party by a method other than a primary and the
166 date of such nomination, as well as the evidence before us that establishes that a party made
167 reasonable attempts to comply with deadlines of the submission process:

- 168 1. The certification of Candidate executed by Leslie Rinaldi, the Chairwoman of the 76th House
169 of Delegates Nominate Committee, on May 9, 2019;
- 170 2. The email of May 13, 2019 from Rinaldi to Leslie Williams at the Department of Elections
171 submitting Clinton L. Jenkins as the Candidate for the Democratic Committee for the 76th
172 District House of Delegates;
- 173 3. Documentation that Rinaldi's May 13, 2019 email was received by the Executive Director of
174 the Virginia House Democrats and the General Registrar of the City of Suffolk; and

175 4. The affidavits of Rinaldi, Jenkins, and Randy Menefee, the Chairman of the Chesapeake
176 Democratic Committee and a member of the Democratic Nominating Committee for the 76th
177 District,

178 Secretary LeCruise then *moved that the Board accept Clinton L. Jenkins as the Democratic nominee*
179 *for the 76th House of Delegates District and that name be placed on the ballot for the 2019 General*
180 *Election as such.* Vice Chair O'Bannon seconded the motion, and the motion passed unanimously.

181 Chairman Brink stated that the Board will defer the action involving the determination of
182 candidate qualification for the 30th House of Delegate District, in order to gain additional
183 guidance from the Office of Attorney General.

184 Chairman Brink opened the floor to public comment. Mr. Woodfin asked the Board for an
185 expected timeline for the determination to be made, and whether the Board would entertain a
186 motion to accept the ELECT-511 form for Mr. Freitas. The Chairman stated that it would be best
187 to receive guidance from the Office of the Attorney General on the interrelationship of the issues
188 between SBE-501 and ELECT-511.

189 Chairman Brink adjourned the meeting at 3:36 P.M.

190

191

192 _____

193 Secretary

194 _____

195 Chairman

196 _____

197 Vice Chairman

1
2
3
4
5
6
7
8
9
10
11
12
13
14
15
16
17
18
19
20
21
22
23
24
25
26
27
28

The Friday, July 19, 2019, State Board of Elections meeting was held in the Martha Brissette Conference Room of the Washington Building in Richmond, Virginia. In attendance: Robert Brink, Chairman, John O’Bannon, Vice Chairman, and Jamilah LeCruise, Secretary, represented the State Board of Elections (“the Board”). Christopher E. “Chris” Piper, Commissioner, Jessica Bowman, Deputy Commissioner, represented the Department of Elections (“ELECT”). Heather Hays Lockerman represented the Office of the Attorney General (“OAG”). Chairman Brink called the meeting to order at 2:00 P.M.

Vice Chair O’Bannon *moved that the Board go into closed session for the purpose of consultation with legal counsel and briefings by staff members or consultants for the purpose of receiving legal advice concerning the 30th House District nomination, as authorized by Section 2.2-3711(A)(8) of the Code of Virginia. In accordance with Virginia Code Section 2.2-3712(F), Heather Hays Lockerman from the Office of the Attorney General, as well as Christopher Piper, Commissioner of Elections and Jessica Bowman, Deputy Commissioner of Election will attend the closed session because their presence will reasonably aid the Board in its consideration of the subject of the meeting.* Secretary LeCruise seconded the motion, and the motion passed unanimously.

Secretary LeCruise *moved to reconvene in open session, and take a roll call vote certifying that to the best of each member’s knowledge (i) only such public business matters lawfully exempted from open meeting requirements under this chapter and (ii) only such public business matters as were identified in the motion by which the closed meeting was concerned were heard, discussed, or considered.* Vice Chair O’Bannon seconded the motion, and the motion passed unanimously. A roll call vote was taken:

- Secretary LeCruise – aye
- Vice Chair O’Bannon – aye
- Chairman Brink – aye

Vice Chair O’Bannon *moved to adjourn the meeting.* Secretary LeCruise seconded the motion, the motion passed unanimously. The meeting adjourned at approximately 2:22 P.M.

29 _____

30 Secretary

31 _____

32 Chairman

33 _____

34 Vice Chairman

35

36

37

38

39



★ VIRGINIA ★
STATE BOARD *of* ELECTIONS

Commissioner's Report

BOARD WORKING PAPERS
Christopher E. "Chris" Piper
Commissioner

BakerHostetler

Baker&Hostetler LLP

Washington Square, Suite 1100
1050 Connecticut Avenue, N.W.
Washington, DC 20036-5403

T 202.861.1500
F 202.861.1783
www.bakerlaw.com

Trevor M. Stanley
direct dial: 202.861.1551
tstanley@bakerlaw.com

August 5, 2019

VIA E-MAIL

Christopher E. Piper, Commissioner
Virginia Department of Elections
1100 Bank Street, Floor 1
Richmond, Virginia 23219

Re: Nomination of Candidate Pursuant to Va. Code § 24.2-539

Dear Commissioner Piper:

We represent the Republican Party of Virginia (the “RPV”). We are in receipt of a letter from Dave Nichols, your Department’s Election Services Manager, to Bruce Kay, Chairman of the 30th District Legislative District Committee, regarding the 30th District’s nominee, Nick J. Freitas. We now ask for clarification from the Department regarding the meaning of that letter.

Mr. Nichols’s letter appears to be inconsistent with the Virginia Code. As you know, the RPV selected Delegate Nick J. Freitas as its nominee for House District 30 in accordance with Va. Code § 24.2-510. The RPV then renominated Delegate Freitas in accordance with Va. Code § 24.2-539. Chairman Kay then submitted a form regarding the renomination to the Department of Elections. Instead of accepting the form, the Department determined that “[a]ll applicable deadlines have passed and the Department is not able to accept the form.” This statement is unclear for two reasons: First, it is unclear what deadlines the Department is claiming “have passed.” Second, the Department’s position is inconsistent with Va. Code § 24.2-539.

Both nominations of Delegate Freitas complied with the Virginia Code. Va. Code § 24.2-539 expressly states, “Should the nominee of any party die, withdraw, or have his nomination set aside for any reason, the party may nominate to fill the vacancy in accordance with its own rules.” The RPV complied with this provision when it nominated Delegate Freitas in compliance with Va. Code § 24.2-539 after he was nominated in accordance with Va. Code § 24.2-510. The Department’s letter does not address whether the first or the second nomination of Delegate Freitas complied with the Virginia Code.

August 5, 2019

Page 2

In addition, the Department's letter does not indicate whether a new individual could be nominated to replace Delegate Freitas. In the event the Department takes the position that Delegate Freitas was "disqualified for failing to meet the filing requirements of Article 1," a position we believe to be incorrect, the RPV has the authority "to fill the vacancy in accordance with its own rules." *See* Va. Code § 24.2-539. The Department's letter, however, provides no guidance on this matter.

At this point, either Delegate Freitas is the nominee or he is not. Under either scenario, the RPV is entitled to have a candidate on the ballot for the 30th District, and the Department cannot deprive the citizens of the 30th District the opportunity to elect their preferred candidate. We respectfully request that the Department clarify its position on: 1) whether Delegate Freitas was properly nominated in accordance with Va. Code § 24.2-539; and, if the answer to question 1 is no, 2) whether the RPV can fill the vacancy in accordance with its own rules. We respectfully request an answer by 5 pm on August 5, 2019 in the event additional action must be taken by the RPV before ballots are printed for the 30th District.

We appreciate your attention to this matter and the significant work the Department of Elections and local officials undertake each year to ensure fair, open, and honest elections in the Commonwealth.

Should you have any questions or concerns, please feel free to contact me by email at tstanley@bakerlaw.com or by phone at 202-861-1551.

Sincerely,

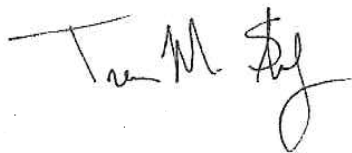
A handwritten signature in black ink, appearing to read "Trevor M. Stanley". The signature is written in a cursive style with a large, stylized "S" at the end.

Trevor M. Stanley

cc: Robert H. Brink, Chairman
John O'Bannon, Vice-Chairman
Jamilah D. LeCruise, Secretary
Heather Hays Lockerman, Esq.
Dave Nichols, Election Services Manager
Chris Marston, Esq.



★ VIRGINIA ★
STATE BOARD *of* ELECTIONS

ES & S EVS 6.0.4.0 Certification

BOARD WORKING PAPERS
Eugene Burton
Voting Technology Coordinator



★ VIRGINIA ★
DEPARTMENT *of* ELECTIONS

Memorandum

To: Chairman Brink, Vice Chair O'Bannon and Secretary LeCruise

From: Eugene Burton, Voting Technology Coordinator

Date: August 6, 2019

Re: ES&S EVS 6.0.4.0 Voting System Certification

Suggested motion for Board Member to make:

I move that the Board certify the use of ES&S EVS 6.0.4.0 in elections in the Commonwealth of Virginia, pursuant to the *State Certification of Voting Systems: Requirements and Procedures*.

Applicable Code Section: § 24.2-629

Attachments:

Your Board materials include the following:

- EAC Agency Decision Grant of Certification Letter
- EAC Certificate of Conformance
- ES&S EVS 6.0.4.0 Virginia Test Report provided by SLI Compliance Lab
- June 11, 2019, Stafford County Pilot Primary Election Day Letter
- Virginia State Certification of Voting Systems Requirements and Procedures

Background:

Following the steps prescribed in the *Virginia State Certification of Voting Systems: Requirements and Procedures*, ES&S initiated the certification evaluation to the Department of Elections on April 15, 2019. ES&S provided their Technical Data Package and Corporate Information (required under step 2 of the *Requirements and Procedures*). Both of these submissions were deemed complete and in sufficient detail to warrant Step 3, the Preliminary Review. During the preliminary review, the state-designated evaluation agent conducted a preliminary analysis of the TDP, Corporate Information, and other materials provided and prepared an Evaluation Proposal (i.e. Test Plan). Upon ES&S agreement with the test plan, the evaluation was conducted on May 20, 2019 through May 22, 2019, in the Department of Elections offices in Richmond, Virginia. In addition the system was successfully piloted in an election in Stafford County on June 11, 2019 Primary Election. The ES&S EVS 6.0.4.0 voting system successfully completed the Virginia Voting Systems State Certification.



U. S. ELECTION ASSISTANCE COMMISSION
VOTING SYSTEM TESTING AND CERTIFICATION PROGRAM
1335 East West Highway, Suite 4300
Silver Spring, MD 20910

May 3, 2019

Sue McKay
Election Systems and Software
11208 John Galt Blvd
Omaha, NE 68137

Sent via e-mail

Re: Agency Decision – Grant of Certification

Dear Ms. McKay,

As required under §5.9 of the EAC's Voting System Testing and Certification Program Manual, ES&S and SLI Compliance have provided the necessary documentation for the EVS 6.0.4.0 voting system verifying that 1) the trusted build has been performed, 2) software has been deposited in an approved repository, 3) system identification tools are available to election officials, and 4) signed a letter stating, under penalty of law, that you have:

1. Performed a trusted build consistent with the requirements of §5.6 of the EAC's Certification Manual;
2. Deposited software consistent with §5.7 of the EAC's Certification Manual;
3. Created and made available system identification tools consistent with §5.8 of the EAC's Certification Manual (a copy and description of the system identification tool developed must be provided with the letter); and
4. Upon a final decision to grant certification, the manufacturer accepts the certification and all conditions placed on the certification.

Based on the review of the documentation above and the fact that ES&S EVS 6.0.4.0 successfully completed conformance testing to the Voluntary Voting System Guidelines Version 1.0 (VVSG 1.0), the Voting System Testing & Certification Program Director has recommended EAC certification of this system.

I have reviewed all of the documentation and concur with the Program Director's recommendation. As such, I hereby grant EAC Certification to ES&S EVS 6.0.4.0 to the VVSG 1.0.

The EAC certification number issued for this system is: **ESSEVS6040**. In addition, a Certificate of Conformance shall be provided to ES&S as evidence of the EAC certification of the EVS 6.0.42.0. The Certificate of Conformance shall be provided to

ES&S no later than five business days from the date of this letter, and it shall be posted on the EAC's website.

As stated in §5.11 of the EAC's Certification Manual, the EAC certification and certificate apply only to the specific voting system configuration(s) identified, submitted, and evaluated under the Certification Program. Any modification to the system not authorized by the EAC shall void the certificate.

If you have any questions or need further information, please do not hesitate to contact Ryan Macias at your earliest convenience. I thank you in advance for your time and attention to this matter and congratulate you on this achievement.

Sincerely,

A handwritten signature in blue ink, appearing to read "BDN", with a large, stylized flourish at the end.

Brian D. Newby
Executive Director
Decision Authority

Cc: Ryan Macias, U.S. Election Assistance Commission
Jonathon Panek, SLI Compliance



United States Election Assistance Commission



Certificate of Conformance

ES&S EVS 6.0.4.0

The voting system identified on this certificate has been evaluated at an accredited voting system testing laboratory for conformance to the *Voluntary Voting System Guidelines Version 1.0 (VVSG 1.0)*. Components evaluated for this certification are detailed in the attached Scope of Certification document. This certificate applies only to the specific version and release of the product in its evaluated configuration. The evaluation has been verified by the EAC in accordance with the provisions of the *EAC Voting System Testing and Certification Program Manual* and the conclusions of the testing laboratory in the test report are consistent with the evidence adduced. This certificate is not an endorsement of the product by any agency of the U.S. Government and no warranty of the product is either expressed or implied.

Product Name: EVS

Model or Version: 6.0.4.0

Name of VSTL: SLI Compliance

EAC Certification Number: ESSEVS6040

Date Issued: May 3, 2019

Executive Director

Scope of Certification Attached

Manufacturer: Election Systems & Software
System Name: EVS 6.0.4.0
Certificate: ESSEVS6040

Laboratory: SLI Compliance
Standard: VVSG 1.0 (2005)
Date: May 3, 2019



Scope of Certification

This document describes the scope of the validation and certification of the system defined above. Any use, configuration changes, revision changes, additions or subtractions from the described system are not included in this evaluation.

Significance of EAC Certification

An EAC certification is an official recognition that a voting system (in a specific configuration or configurations) has been tested to and has met an identified set of Federal voting system standards. An EAC certification is **not**:

- An endorsement of a Manufacturer, voting system, or any of the system's components.
- A Federal warranty of the voting system or any of its components.
- A determination that a voting system, when fielded, will be operated in a manner that meets all HAVA requirements.
- A substitute for State or local certification and testing.
- A determination that the system is ready for use in an election.
- A determination that any particular component of a certified system is itself certified for use outside the certified configuration.

Representation of EAC Certification

Manufacturers may not represent or imply that a voting system is certified unless it has received a Certificate of Conformance for that system. Statements regarding EAC certification in brochures, on Web sites, on displays, and in advertising/sales literature must be made solely in reference to specific systems. Any action by a Manufacturer to suggest EAC endorsement of its product or organization is strictly prohibited and may result in a Manufacturer's suspension or other action pursuant to Federal civil and criminal law.

System Overview

The ES&S EVS 6.0.4.0 voting system is a modification of the ES&S EVS 6.0.2.0 voting system, certified on October 4, 2018, which contains changes in hardware, software, as well as an upgrade in the election management system's COTS operating system. The ES&S EVS 6.0.4.0 voting system is composed of software applications, central count location devices and polling place devices with accompanying firmware, and COTS hardware and software.

Electionware®

Electionware election management software is an end-to-end election management software application that provides election definition creation, ballot formation, equipment

configuration, result consolidation, adjudication and report creation. Electionware is composed of five software groups: Define, Design, Deliver, Results and Manage.

ExpressVote XL™

ExpressVote XL is a hybrid paper-based polling place voting device that provides a full-face touchscreen vote capture that incorporates the printing of the voter's selections as a cast vote record, and tabulation scanning into a single unit.

ExpressTouch®

ExpressTouch Electronic Universal Voting System (ExpressTouch) is a DRE voting system which supports electronic vote capture for all individuals at the polling place.

ExpressVote® Hardware 1.0

ExpressVote Universal Voting System Hardware 1.0 (ExpressVote HW1.0) is a hybrid paper-based polling place voting device that provides touch screen vote capture that incorporates the printing of the voter's selections as a cast vote record, to be scanned for tabulation in any one of the ES&S precinct or central scanners.

ExpressVote® Hardware 2.1

ExpressVote Universal Voting System Hardware 2.1 (ExpressVote HW2.1) is a hybrid paper-based polling place voting device that provides touch screen vote capture that incorporates the printing of the voter's selections as a cast vote record, and tabulation scanning into a single unit. ExpressVote HW2.1 is capable of operating in either marker or tabulator mode, depending on the configurable mode that is selected in Electionware.

There are two separate versions of the ExpressVote hardware version 2.1: 2.1.0.0 and version 2.1.2.0 (6.4 & 6.8). Please note that all future references to ExpressVote HW 2.1 as used throughout the document refers to both hardware versions.

DS200®

DS200 is a polling place paper-based voting system, specifically a digital scanner and tabulator that simultaneously scans the front and back of a paper ballot and/or vote summary card in any of four orientations for conversion of voter selection marks to electronic Cast Vote Records (CVR).

DS450®

DS450 is a central scanner and tabulator that simultaneously scans the front and back of a paper ballot and/or vote summary card in any of four orientations for conversion of voter selection marks to electronic Cast Vote Records (CVR).

DS850®

DS850 is a central scanner and tabulator that simultaneously scans the front and back of a paper ballot and/or vote summary card in any of four orientations for conversion of voter selection marks to electronic Cast Vote Records (CVR).

Event Log Service (ELS)

ELS monitors and logs users' interactions with the Election Management System. Events that happen when a connection to the database is not available are logged to the Windows Operating System log through the ELS.

Removable Media Service (RMS)

RMS is a utility that runs in the background of the Windows operating system. RMS reads specific information from any attached USB devices so that ES&S applications such as Electionware can use that information for media validation purposes.

Configurations

Within the scope of the ES&S EVS 6.0.4.0 voting system, three unique configurations are supported, in order to accommodate limitations of components with the ES&S EVS 6.0.4.0 voting system.

Configuration A

ES&S EVS 6.0.4.0: Test Configuration A is comprised of the entire suite of voting system products.

- Electionware
- ExpressVote Marker (HW 1.0)
- ExpressVote Marker/Tabulator (HW 2.1)
- ExpressVote XL
- ExpressTouch
- DS200
- DS450
- DS850

Configuration B

- Electionware
- ExpressVote Marker (HW 1.0)
- ExpressVote Marker/Tabulator (HW 2.1)
- DS200
- DS450
- DS850

Configuration C

- Electionware
- ExpressVote XL

Mark Definition

ES&S' declared level mark recognition for the DS200, DS450 and DS850 is a mark across the oval that is 0.02" long x 0.03" wide at any direction.

Tested Marking Devices

Bic Grip Roller Pen

Language Capability

EVS 6.0.4.0 supports English, Spanish, Chinese (Cantonese), Korean, Japanese, Hindi, Bengali, Vietnamese, Tagalog, Creole, Russian, and French. Configuration C also supports Punjabi and Gujarati.

Proprietary Components Included

This section provides information describing the components and revision level of the primary components included in this Certification.

System Component	Software or Firmware Version	Hardware Version	Model	Comments
Electionware	5.0.4.0			
ES&S Event Log Service	1.6.0.0			
Removable Media Service	1.5.1.0			
ExpressVote HW 1.0	1.5.2.0	1.0		Paper-based vote capture and selection device
ExpressVote Previewer (1.0)	1.5.2.0			
ExpressVote HW 2.1	2.4.5.0	2.1.0.0 2.1.2.0		Hybrid paper-based vote capture and selection device and precinct count tabulator
ExpressVote Previewer (2.1)	2.4.5.0			
DS200	2.17.4.0	1.2.1, 1.2.3, 1.3, 1.3.11		Precinct Count Tabulator
DS450	3.1.1.0	1.0		Central Count Scanner and Tabulator
DS850	3.1.1.0	1.0		Central Count Scanner and Tabulator
ExpressVote XL	1.0.3.0	1.0		Hybrid full-faced paper-based vote capture and selection device and precinct count tabulator
ExpressTouch	1.0.3.0	1.0		DRE
Delkin USB Flash Drive		USB Flash Drive	Bitlocker 32.2MB	BitLocker USB Flash Drive
ExpressVote Rolling Kiosk		1.0	98-00049	Portable Voting Booth
Voting Booth		N/A	98-00051	Stationary Voting Booth
Quad Express Cart		N/A	41404	Portable Voting Booth
MXB ExpressVote Voting Booth		N/A	95000	Sitting and Standing Voting Booth

System Component	Software or Firmware Version	Hardware Version	Model	Comments
ExpressVote Single Table		N/A	87033	Voting Table for One Unit
ExpressVote Double Table		N/A	87032	Voting Table for Two Units
ADA Table		N/A	87031	Voting Table for One Unit
DS200 Ballot Box		1.0, 1.1	98-00009	Collapsible Ballot Box
DS200 Ballot Box		1.2, 1.3, 1.4, 1.5	57521	Plastic ballot box
DS200 Tote Bin		1.0	00074	Tote Bin Ballot Box
DS450 Cart		N/A	3002	
DS850 Cart		N/A	6823	
Universal Voting Console		1.0	98-00077	Detachable ADA support peripheral
Tabletop Easel		N/A	14040	
ExpressTouch Voting Booth		N/A	98-00081	Stationary Voting Booth
SecureSetup	2.1.0.3			Proprietary Hardening Script

COTS Software

Manufacturer	Application	Version
Microsoft Corporation	Server 2008	R2 w/ SP1 (64-bit)
Microsoft Corporation	Windows 7 Professional	SP1 (64-bit)
Microsoft Corporation	Windows 7 Enterprise	SP1 (64-bit)
Microsoft Corporation	WSUS Microsoft Windows Offline Update Utility	11.5
Symantec	Endpoint Protection	14.2.0_MP1 (64-bit)
Symantec	Symantec Endpoint Protection Intelligent Updater (File-Based Protection)	20190122-001-core15sds5i64.exe
Symantec	Symantec Endpoint Protection Intelligent Updater (Network-Based Protection)	20190121-062-IPS_IU_SEP_14RU1.exe
Symantec	Symantec Endpoint Protection Intelligent Updater (Behavior-Based Protection)	20190115-001-SONAR_IU_SEP.exe
Gigabyte	WindowsImageTool	B17.1116.01
Cerberus	CerberusFTP Server – Enterprise	10.0.5 (64-bit)
Adobe	Acrobat	XI
Microsoft Corporation	Visual C++ Redistributable	en_visual_cpp_2015_redistributable_x86_8487157.exe (32-bit)
RSA Security	RSA BSAFE Crypto-C ME for Windows 32-bit	4.1
OpenSSL	OpenSSL	2.0.12
OpenSSL	OpenSSL	2.0.16
OpenSSL	OpenSSL	1.02d
OpenSSL	OpenSSL	1.02h
OpenSSL	OpenSSL	1.02k

COTS Hardware

Manufacturer	Hardware	Model/Version
Dell	EMS Server	PowerEdge T420, T630
Dell	EMS Client or Standalone Workstation	Latitude 5580, E6430 OptiPlex 5040, 5050, 7020
Dell	Trusted Platform Module (TPM) Chip version 1.2	R9X21
Innodisk	USB EDC H2SE (1GB) for ExpressVote 1.0	DEEUH1-01GI72AC1SB
Innodisk	USB EDC H2SE (16GB) for ExpressVote 2.1	DEEUH1-16GI72AC1SB
Delkin	USB Flash Drive (512MB, 1GB, 2GB, 4GB, 8GB)	N/A
Delkin	Validation USB Flash Drive (16 GB)	N/A
Delkin	USB Embedded 2.0 Module Flash Drive	MY16TNK7A-RA042-D/ 16 GB
Delkin	Compact Flash Memory Card (1GB)	CE0GTFHHK-FD038-D
Delkin	Compact Flash Memory Card Reader/Writer	6381
Delkin	CFAST Card (2GB, 4GB)	N/A
Lexar	CFAST Card Reader/Writer	LRWCR1TBNA
CardLogix	Smart Card	CLXSU128kC7/ AED C7
SCM Microsystems	Smart Card Writer	SCR3310
Avid	Headphones	86002
Zebra Technologies	QR code scanner (Integrated)	DS457-SR20009, DS457-SR20004ZZWW
Symbol	QR Code scanner (External)	DS9208
Dell	DS450 Report Printer	S2810dn
OKI	DS450 and DS850 Report Printer	B431dn, B431d, B432DN
OKI	DS450 and DS850 Audit Printer	Microline 420
APC	DS450 UPS	Back-UPS Pro 1500, Smart-UPS 1500
APC	DS850 UPS	Back-UPS RS 1500, Pro 1500
Tripp Lite	DS450 and DS850 Surge Protector	Spike Cube
Seiko Instruments	Thermal Printer	LTPD-347B
NCR/Nashua	Paper Roll	2320
Fujitsu	Thermal Printer	FTP-62GDSL001, FTP-63GMCL153

Configuration Diagrams

Configuration A

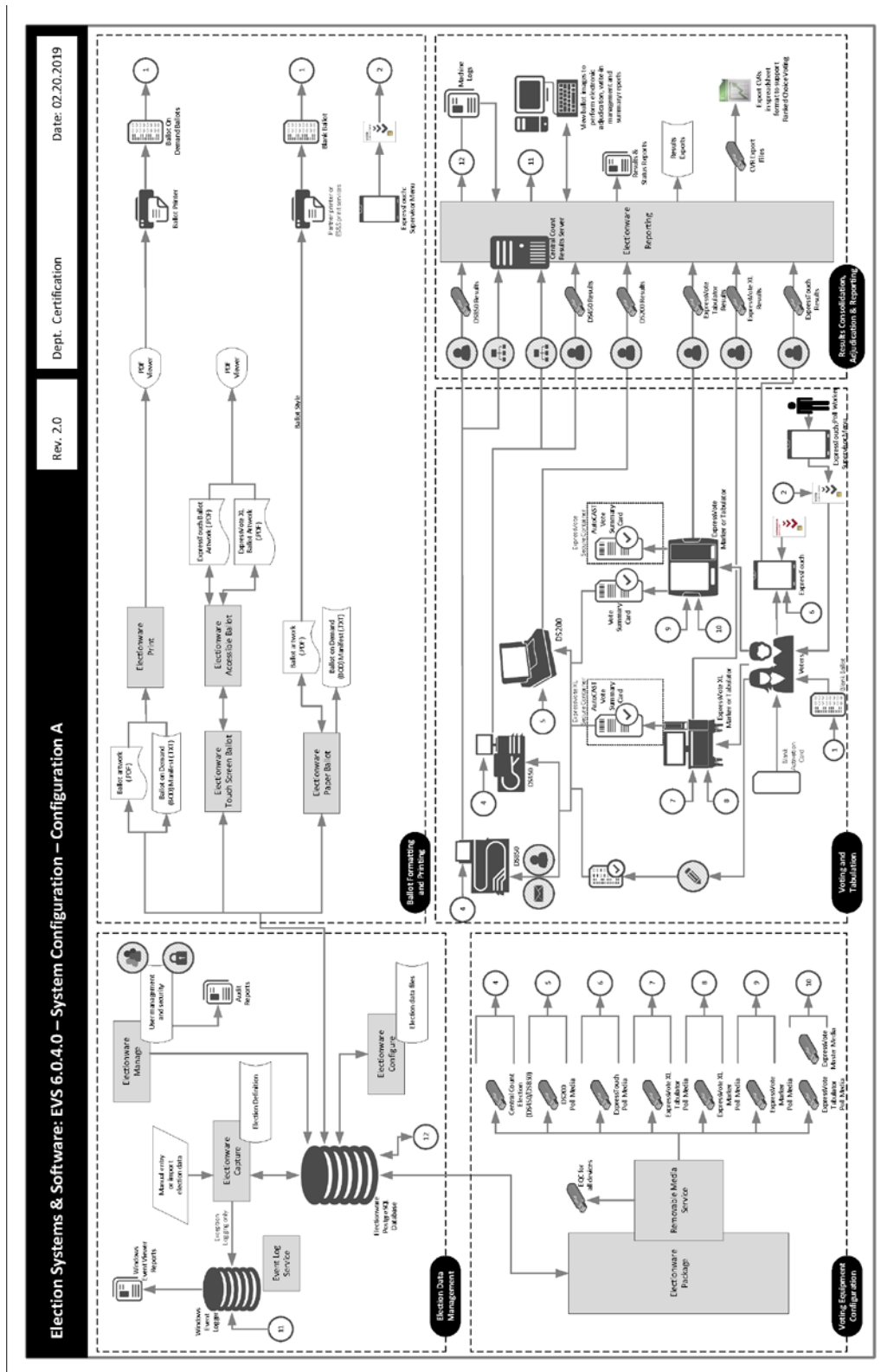

Configuration B

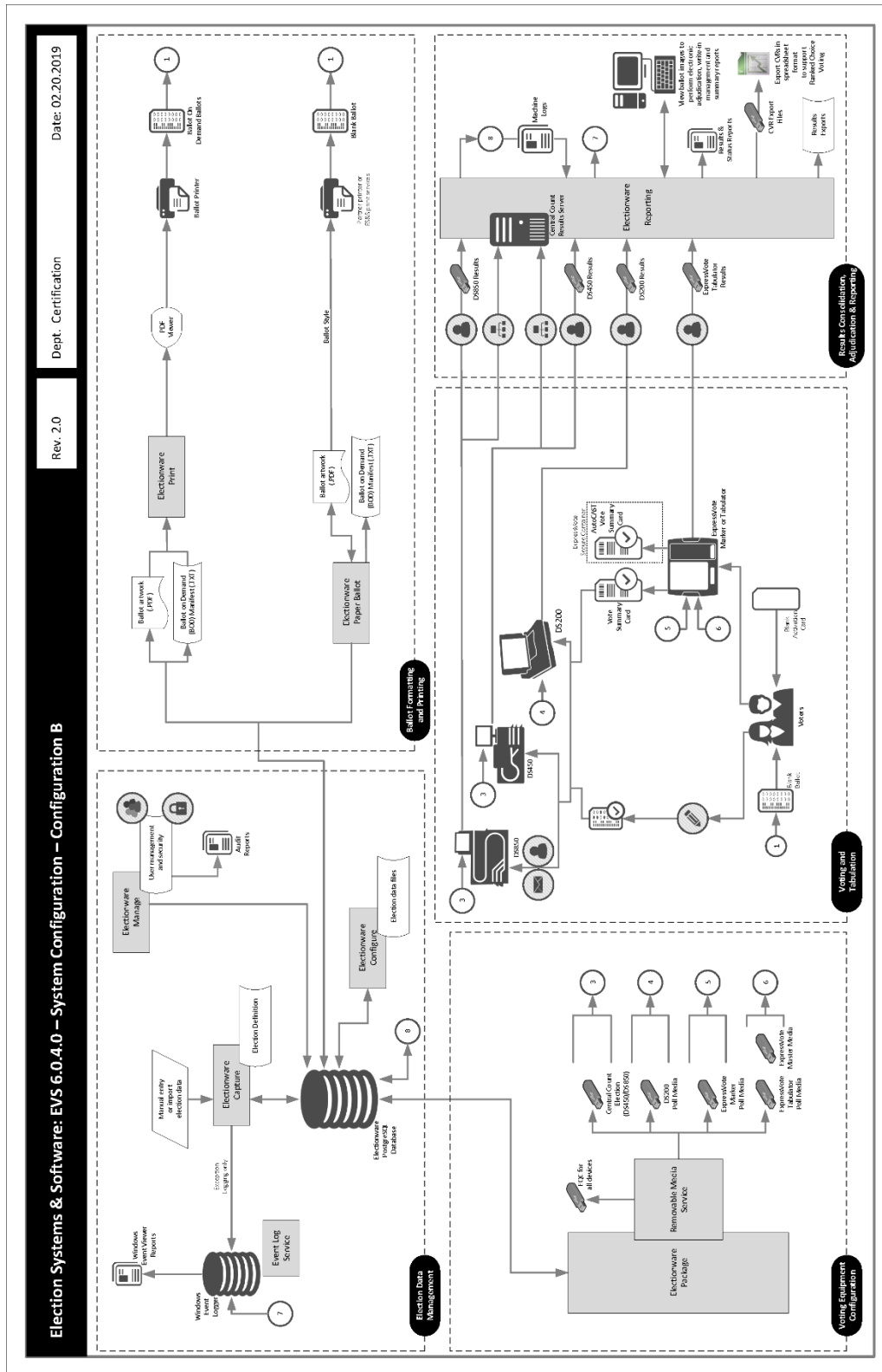

System Limitations

This table depicts the limits the system has been tested and certified to meet.

System Characteristic	Boundary or Limitation	Limiting Component
Max. precincts allowed in an election	9,900	Electionware
Max. ballot styles in an election	15,000	Electionware
Max. candidates allowed per election	10,000	Electionware
Max. contests allowed in an election	10,000	Electionware
Max. number of parties allowed	General election: 75 Primary election: 30	Electionware
Max. District Types/Groups	25	Electionware
Max. districts of a given type	250	
Max. Contests allowed per ballot style	500	
Max. Reporting Groups in an election	14	Electionware
Max. candidates allowed per contest	230	Electionware
Max. "Vote For" per contest	230	Electionware
Max. ballots per batch	1,500	DS45/DS850

Component Limitations:

Electionware

1. Electionware software field limits were calculated based on an average character width for ballot and report elements. Some uses and conditions, such as magnified ballot views or combining elements on printed media or ballot displays, may result in field limits (and associated warnings) lower than those listed. Check printed media and displays before finalizing the election.
2. The Electionware Export Ballot Images function is limited to 250 districts per export.
3. Electionware supports the language special characters listed in the System Overview, Attachment 1. Language special characters other than those listed may not appear properly when viewed on equipment displays or reports.
4. The Straight Party feature must not be used in conjunction with the Single or Multiple Target Cross Endorsement features.

5. The 'MasterFile.txt' and the 'Votes File.txt' do not support results for elections that contain multiple sheets or multiple ExpressVote cards per voter. These files can be produced using the Electionware > Reporting > Tools > Export Results menu option. This menu option is available when the Rules Profile is set to "Illinois".

Paper Ballot Limitations

1. The paper ballot code channel, which is the series of black boxes that appear between the timing track and ballot contents, limits the number of available ballot variations depending on how a jurisdiction uses this code to differentiate ballots. The code can be used to differentiate ballots using three different fields defined as: Sequence (available codes 1-16,300), Type (available codes 1-30) or Split (available codes 1-18).
2. If Sequence is used as a ballot style ID, it must be unique election-wide and the Split code will always be 1. In this case the practical style limit would be 16,300.
3. The ExpressVote activation card has a limited ballot ID based on the three different fields defined as: Sequence (available codes 1-16,300), Type (available codes 1-30) or Split (available codes 1-18).
4. Grid Portrait and Grid Landscape ballot types are New York specific and not for general use.

ExpressVote

1. ExpressVote capacities exceed all documented limitations for the ES&S election management, vote tabulation and reporting system. For this reason, Election Management System and ballot tabulator limitations define the boundaries and capabilities of the ExpressVote system as the maximum capacities of the ES&S ExpressVote are never approached during testing.

ExpressVote XL

1. ExpressVote XL capacities exceed all documented limitations for the ES&S election management, vote tabulation and reporting system. For this reason, Election Management System and ballot tabulator limitations define the boundaries and capabilities of the ExpressVote XL system as the maximum capacities of the ES&S ExpressVote XL are never approached during testing.
2. ExpressVote XL does not offer open primary support based on the ES&S definition of Open Primary, which is the ability to select a party and vote based on that party.
3. ExpressVote XL does not support Massachusetts Group Vote.
4. ExpressVote XL does not support Universal Primary Contest.
5. ExpressVote XL does not support Multiple Target Cross Endorsement.
6. ExpressVote XL does not support Reviewer or Judges Initials boxes.
7. ExpressVote XL does not support multi-card ballots.
8. In a General election, one ExpressVote XL screen can hold 32 party columns if set up as columns or 16 party rows if set up as rows.
9. ExpressVote XL does not support Team Write-In.

ExpressTouch

1. ExpressTouch capacities exceed all documented limitations for the ES&S election management, vote tabulation and reporting system. For this reason, Election Management System limitations define the boundaries and capabilities of the ExpressTouch system as the maximum capacities of the ES&S ExpressTouch are never approached during testing.

2. ExpressTouch does not offer open primary support, which is the ability to select a party and vote based on that party.
3. ExpressTouch does not support Massachusetts Group Vote.
4. ExpressTouch does not support Universal Primary Contest.
5. ExpressTouch does not support Multiple Target Cross Endorsement.
6. ExpressTouch does not support Team Write-In.

DS200

1. The ES&S DS200 configured for an early vote station does not support precinct level results reporting. An election summary report of tabulated vote totals is supported.
2. The DS200 storage limitation for write-in ballot images is 3,600 images. Each ballot image includes a single ballot face, or one side of one page.
3. Write-in image review requires a minimum 1GB of onboard RAM.
4. To successfully use the Write-In Report, ballots must span at least three vertical columns. If the column is greater than 1/3 of the ballot width (two columns or less), the write-in image will be too wide to print on the tabulator report tape.

Functionality

VVSG 1.0 Supported Functionality Declaration

Feature/Characteristic	Yes/No	Comment
Voter Verified Paper Audit Trails		
VVPAT	No	
Accessibility		
Forward Approach	Yes	
Parallel (Side) Approach	Yes	
Closed Primary		
Primary: Closed	Yes	
Open Primary		
Primary: Open Standard (provide definition of how supported)	Yes	Configuration B only
Primary: Open Blanket (provide definition of how supported)	No	
Partisan & Non-Partisan:		
Partisan & Non-Partisan: Vote for 1 of N race	Yes	
Partisan & Non-Partisan: Multi-member ("vote for N of M") board races	Yes	
Partisan & Non-Partisan: "vote for 1" race with a single candidate and write-in voting	Yes	
Partisan & Non-Partisan "vote for 1" race with no declared candidates and write-in voting	Yes	
Write-In Voting:		
Write-in Voting: System default is a voting position identified for write-ins.	Yes	
Write-in Voting: Without selecting a write in position.	Yes	
Write-in: With No Declared Candidates	Yes	
Write-in: Identification of write-ins for resolution at central count	Yes	
Primary Presidential Delegation Nominations & Slates:		
Primary Presidential Delegation Nominations: Displayed delegate slates for each presidential party	No	

Feature/Characteristic	Yes/No	Comment
Slate & Group Voting: one selection votes the slate.	No	
Ballot Rotation:		
Rotation of Names within an Office; define all supported rotation methods for location on the ballot and vote tabulation/reporting	Yes	
Straight Party Voting:		
Straight Party: A single selection for partisan races in a general election	Yes	
Straight Party: Vote for each candidate individually	Yes	
Straight Party: Modify straight party selections with crossover votes	Yes	
Straight Party: A race without a candidate for one party	Yes	
Straight Party: N of M race (where "N">1)	Yes	
Straight Party: Excludes a partisan contest from the straight party selection	Yes	
Cross-Party Endorsement:		
Cross party endorsements, multiple parties endorse one candidate.	Yes	
Split Precincts:		
Split Precincts: Multiple ballot styles	Yes	
Split Precincts: P & M system support splits with correct contests and ballot identification of each split	Yes	
Split Precincts: DRE matches voter to all applicable races.	Yes	
Split Precincts: Reporting of voter counts (# of voters) to the precinct split level; Reporting of vote totals is to the precinct level	Yes	It is possible to list the number of voters.
Vote N of M:		
Vote for N of M: Counts each selected candidate, if the maximum is not exceeded.	Yes	
Vote for N of M: Invalidates all candidates in an overvote (paper)	Yes	
Recall Issues, with options:		
Recall Issues with Options: Simple Yes/No with separate race/election. (Vote Yes or No Question)	No	
Recall Issues with Options: Retain is the first option, Replacement candidate for the second or more options (Vote 1 of M)	No	
Recall Issues with Options: Two contests with access to a second contest conditional upon a specific vote in contest one. (Must vote Yes to vote in 2 nd contest.)	No	
Recall Issues with Options: Two contests with access to a second contest conditional upon any vote in contest one. (Must vote Yes to vote in 2 nd contest.)	No	
Cumulative Voting		
Cumulative Voting: Voters are permitted to cast, as many votes as there are seats to be filled for one or more candidates. Voters are not limited to giving only one vote to a candidate. Instead, they can put multiple votes on one or more candidate.	No	
Ranked Order Voting		
Ranked Order Voting: Voters can write in a ranked vote.	No	
Ranked Order Voting: A ballot stops being counting when all ranked choices have been eliminated	No	

Feature/Characteristic	Yes/No	Comment
Ranked Order Voting: A ballot with a skipped rank counts the vote for the next rank.	No	
Ranked Order Voting: Voters rank candidates in a contest in order of choice. A candidate receiving a majority of the first choice votes wins. If no candidate receives a majority of first choice votes, the last place candidate is deleted, each ballot cast for the deleted candidate counts for the second choice candidate listed on the ballot. The process of eliminating the last place candidate and recounting the ballots continues until one candidate receives a majority of the vote	No	
Ranked Order Voting: A ballot with two choices ranked the same, stops being counted at the point of two similarly ranked choices.	No	
Ranked Order Voting: The total number of votes for two or more candidates with the least votes is less than the votes of the candidate with the next highest number of votes, the candidates with the least votes are eliminated simultaneously and their votes transferred to the next-ranked continuing candidate.	No	
Provisional or Challenged Ballots		
Provisional/Challenged Ballots: A voted provisional ballots is identified but not included in the tabulation but can be added in the central count.	Yes	
Provisional/Challenged Ballots: A voted provisional ballots is included in the tabulation, but is identified and can be subtracted in the central count	Yes	
Provisional/Challenged Ballots: Provisional ballots maintain the secrecy of the ballot.	Yes	
Overvotes (must support for specific type of voting system)		
Overvotes: P & M: Overvote invalidates the vote. Define how overvotes are counted.	Yes	
Overvotes: DRE: Prevented from or requires correction of overvoting.	Yes	
Overvotes: If a system does not prevent overvotes, it must count them. Define how overvotes are counted.	Yes	
Overvotes: DRE systems that provide a method to data enter absentee votes must account for overvotes.	Yes	
Undervotes		
Undervotes: System counts undervotes cast for accounting purposes	Yes	
Blank Ballots		
Totally Blank Ballots: Any blank ballot alert is tested.	Yes	
Totally Blank Ballots: If blank ballots are not immediately processed, there must be a provision to recognize and accept them	Yes	
Totally Blank Ballots: If operators can access a blank ballot, there must be a provision for resolution.	Yes	
Networking		
Wide Area Network – Use of Modems	No	
Wide Area Network – Use of Wireless	No	
Local Area Network – Use of TCP/IP	No	
Local Area Network – Use of Infrared	No	

Feature/Characteristic	Yes/No	Comment
Local Area Network – Use of Wireless	No	
FIPS 140-2 validated cryptographic module	Yes	
Used as (if applicable):		
Precinct counting device	Yes	DS200, ExpressTouch, ExpressVote HW2.1, ExpressVote XL
Central counting device	Yes	DS450 and/or DS850

Baseline Certification Engineering Change Order's (ECO)

This table depicts the ECO's certified with the voting system:

Change ID	Date	Component	Description	Inclusion
ECO 938	12/14/18	DS200	Texture Free Surface for Security Seals	DeMinimis Optional
ECO 982	2/20/19	ExpressVote XL	Add Cord Wrap Hooks, Filler for Card Bin and Shipping Bracket	DeMinimis Optional
ECO 988	4/29/19	ExpressVote	Add End of Life Zebra Scanner	DeMinimis Optional
ECO 989	4/29/19	ExpressVote	Adds Updated USB Thumb Drive Cover	DeMinimis Optional
ECO 991	4/29/19	DS200	Add Hardware Rev 1.3.11	Non-DeMinimis Optional
ECO 993	4/29/19	DS450	Adds Oki 432 Report Printer and APC Smart-UPS 1500	Non-DeMinimis Optional
ECO 1000	2/13/19	DS200 Collapsible Ballot Box	Adds Hardware Rev 1.1	De Minimis Optional
ECO 1004	12/14/18	DS450	Add Oki 432 Report Printer Due to End of Life	De Minimis Optional
ECO 1005	12/14/18	DS850	Add Oki 432 Report Printer Due to End of Life	De Minimis Optional
ECO 1016	2/13/19	ExpressVote Voting Booth	Added Enhanced Doors	De Minimis Optional
ECO 2160	4/29/19	ExpressVote	Lengthen Detachable Key Pad Cord	De Minimis Optional

Test Report

ES&S EVS 6.0.4.0

State Certification Testing

May 20-22, 2019

Virginia Department of Elections

1100 Bank Street, 1st floor

Richmond, VA 23219

Prepared By: SLI Compliance

4720 Independence Street

Wheat Ridge, Colorado 80033

1 Authority

Section § 24.2-629 of the *Code of Virginia* authorizes the Virginia Department of Elections, in the manner prescribed by the Board, to have examined a production model of such equipment and ballots associated with a vendors request for State Certification.

The corresponding Virginia State Certification of Voting Systems *Requirements and Procedures* (Rev. 3/3/2010) prescribes the manner of which the Virginia Department of Elections will conduct the state certification testing. Subsequent to the evaluation, the Board is required to prepare and file in its office a report of its finding as to:

- (i) the apparent capability of such equipment to accurately count, register, and report votes;
- (ii) whether the system can be conveniently used without undue confusion to the voter;
- (iii) its accessibility to voters with disabilities;
- (iv) whether the system can be safely used without undue potential for fraud;
- (v) the ease of its operation and transportation by voting equipment custodians and officers of election;
- (vi) the financial stability of the vendor and manufacturer;
- (vii) whether the system meets the requirements of this title;
- (viii) whether the system meets federal requirements;
- (ix) whether issues of reliability and security identified with the system by other state governments have been adequately addressed by the vendor; and
- (x) whether, in the opinion of the Board, the potential for approval of such system is such as to justify further examination and testing.

2 Background

Following the steps prescribed in the Virginia State Certification of Voting Systems *Requirements and Procedures* (Rev. 4/2012), Election Systems and Software (ES&S) initiated the certification evaluation by a letter to the Virginia Department of Elections. Additionally, ES&S provided their corresponding Technical Data Package and Corporate Information (required under step 2 of the *Requirements and Procedures*) along with the letter. Both of these submissions were deemed complete and in sufficient detail to warrant Step 3, the Preliminary

Review. During the preliminary review, the state-designated evaluation agent (SLI Compliance) conducted a preliminary analysis of the TDP, Corporate Information, and other materials provided and prepared an Evaluation Proposal (i.e. Test Plan). The evaluation was conducted on May 20-22, 2019 in the Virginia Department of Elections offices in Richmond, Virginia.

The EVS 6.0.4.0 system, was successfully certified by the EAC on May 3rd, 2019, signifying successful completion of conformance testing to the 2005 *Voluntary Voting System Guidelines (VVSG)*.

The evaluation focused on the ElectionWare software and the ExpressVote 1.0, ExpressVote 2.1 (marking mode) Universal Voting System as well as firmware for the DS200, DS450 and DS850.

3 Testing Overview

The evaluation of EVS 6.0.4.0 system was designed to achieve the goals set forth in the test plan. The goals were constructed to verify that the EVS 6.0.4.0 conforms to the *Code of Virginia*. The evaluation successfully addressed each of the test goals in the following way:

Test Goal	Testing Response
Ensure EVS 6.0.4.0 provides support for all Virginia election management requirements (i.e. ballot design, results reporting, etc).	This was tested by evaluating the EVS 6.0.4.0 with 7 Virginia specific election scenarios using a combination of different ballot programming approaches, ballot designs, ballot sizes, languages, and tabulators. The programmed elections were actual elections from Virginia counties. The end-to-end scenario was directly from elections in Virginia.
Simulate pre-election, Election Day, absentee, and post-election activities on the DS200 and corresponding components of the EVS 6.0.4.0 EMS for 7 election scenarios	The DS200 was tested in pre-election, in-person absentee, Election Day, absentee, post-election and recount situations and evaluated against documented behavior and expected results for all 7 scenarios.

Simulate pre-election, Election Day, and post-election activities on the EV2.1 (marking mode) device and corresponding components of the EVS 6.0.4.0 EMS for 7 election scenarios

The EV2.1 (marking mode) was tested in pre-election, Election Day situations and evaluated against documented behavior and expected results.

Simulate pre-election, Election Day, and post-election activities on the EV1.0 ballot marking device and corresponding components of the EVS 6.0.4.0 EMS for 7 election scenarios

The EV1.0 ballot marking device was tested in pre-election, Election Day situations and evaluated against documented behavior and expected results.

Simulate pre-election, Election Day, and post-election activities on the DS450 and corresponding components of the EVS 6.0.4.0 EMS for 7 election scenarios.

The DS450 was tested in pre-election, in-person absentee, Election Day, absentee, and post-election situations and evaluated against documented behavior and expected results.

Simulate pre-election, Election Day, and post-election activities on the DS850 and corresponding components of the EVS 6.0.4.0 EMS for 7 election scenarios.

The DS50 was tested in pre-election, in-person absentee, Election Day, absentee, and post-election situations and evaluated against documented behavior and expected results.

4 Testing Setup

The evaluation consisted of 7 election scenarios to be executed utilizing one setup of the EVS 6.0.4.0 system. It was configured in the standalone configuration with a single EMS workstation executing the EVS software detailed in section 0 below. This setup included four DS200 tabulators, DS450 tabulator, DS850 tabulator and one ExpressVote 1.0 and two ExpressVote 2.1 devices.

EVS 6.0.4.0 further supports a closed network configuration. This configuration may be suitable for jurisdictions that scan absentee ballots on central tabulators (DS450/DS850) and is designed to send results and ballot images from the central tabulators to the Election Management System (EMS) instead of exporting files to a 8GB USB device when scanning is complete. Sending results via the closed network was executed in Scenarios 1, 2, 5 & 6 to ensure the functionality works as designed.

The following election scenarios were used for the evaluation:

Pre-programmed scenarios:

1. Hanover 2009 Primary Election, 14-inch ballots
2. Chesterfield 2007 General Elections, 14-inch ballots
3. Chesterfield 2008 General Elections, 14-inch ballots
4. Chesterfield 2009 Primary Election, 11-inch ballots
5. Fairfax (or equivalent size/complexity) 2010 General Election Multi-Language (English, Spanish), 17-inch ballots
6. Fairfax (or equivalent size/complexity) 2011 Primary Election Multi-Language (English, Spanish), 17-inch ballots

End-to-end scenario:

7. Fairfax (or equivalent size/complexity) General Election (with Preference language) Multi-Language (English, Spanish), 11-inch ballots.
8. Recount for scenario 5, above.

The pre-programmed scenarios were programmed by ES&S prior to the evaluation and were executed from the point where the election definition was completed in ElectionWare. Each testing scenario began with opening the election, reviewing the election definition, and proceeding with the remaining preparations for Election Day and absentee voting.

The end-to-end scenario created a new election for an existing county, generate elections definitions for the tabulators and verify loading of the election definition on the tabulators.

More details on the testing setup are found below:

Election Scenario	Ballot Programming	EVS 6.0.4.0 Configuration	Equipment Used	Ballot Length	Languages	# Ballots Cast
Hanover 2009 Primary Election	Ballot Style	Standalone workstation	EV1.0, EV2.1, DS200, DS450, DS850	14-inch	English	587
Chesterfield 2007 General Election	Precinct	Standalone workstation	EV1.0, EV2.1, DS200, DS450, DS850	14-inch	English	210
Chesterfield 2008 General Election	Ballot Style	Standalone workstation	EV1.0, EV2.1, DS200, DS450, DS850	14-inch	English	504
Chesterfield 2009 Primary Election	Ballot Style	Standalone workstation	EV1.0, EV2.1, DS200, DS450, DS850	11-inch	English	315
Fairfax 2010 General Election	Precinct	Standalone workstation	EV1.0, EV2.1, DS200, DS450, DS850	17-inch	English, Spanish	20,640
Fairfax 2011 Primary Election	Ballot Style	Standalone workstation	EV1.0, EV2.1, DS200, DS450, DS850	17-inch	English Spanish	816
Fairfax 2012 Primary Election (End-to-End)	Precinct	Standalone workstation	EV1.0, EV2.1, DS200, DS450, DS850	11-inch	English, Spanish	660
Fairfax 2010 General Recount	Precinct	Standalone workstation	EV1.0, EV2.1, DS200, DS450, DS850	14-inch	English, Spanish	339

4.1 Testing Candidate

Supporting the evaluation, ES&S provided the following components of the EVS 6.0.4.0 system, which were verified by serial number, hardware version, and firmware/software version.

Virginia State Certification of EVS 6.0.4.0 Compliance 2005 VVSG Standard		EVS 5.2.0.2 VA Certified: 5/13/2015	EVS 6.0.4.0 VA Certified: TBD
Election Management System (EMS)	Electionware	4.6.0.0	5.0.4.0
	Election Reporting Manager (ERM)	8.11.0.0	Incorporated into Electionware
	Removable Media Service Event Log Service	1.4.5.0 1.5.5.0	1.5.1.0 1.6.0.0
	VAT Previewer	1.8.6.0	NA
	ExpressVote Previewer	1.4.0.0	1.5.2.0/2.4.5.0
	Expresslink (Optional Utility)	1.1.0.0	1.5.0.0
	Toolbox (Optional Utility)	2.0.0.0	3.5.0.0
ES&S Tabulators	DS200 Precinct Tabulator (HW 1.2 & 1.3)	2.12.0.2	2.17.4.0
	DS850 Central Tabulator (HW 1.0)	2.10.0.0	3.1.1.0
	DS450 Central Tabulator (HW 1.0)	NA	3.1.1.0
Voter Assist Terminal (VAT)	AutoMARK (HW 1.0, 1.1 & 1.3)	1.8.5.0	NA
Universal Voting System	ExpressVote (Marker Mode)	1.4.0.0	1.5.2.0 (HW 1.0) 2.4.5.0 (HW 2.1)

4.2 Test Decks

Test decks for the pre-programmed scenarios were provided by ES&S and verified by the test team. Ballots were provided and marked in the manner prescribed in the Test Plan.

19. § 24.2-629. The voting system shall prevent fraudulent use.

Passed: Yes

Anomalies Reported: None

The EVS 6.0.4.0 system met the following condition(s) of satisfactions:

- ✓ Each component provides physical and logical access controls.
- ✓ Each component prevents unauthorized individuals from manipulating voting system configurations, controls, or tabulated results.
- ✓ Each component provides mechanisms for detecting fraudulent use from authorized and unauthorized actors.

The EVS 6.0.4.0 system was determined to provide a sufficient level of security controls to prevent fraudulent use when coupled with standard security and ballot accounting procedures. For example, each component provides physical and logical access controls with the ability to use tamper evident seals to detect access attempts. Each component further prevents unauthorized individuals from manipulating voting system firmware, configurations, controls, or tabulated results without the proper access credentials. In conclusion, each component provides mechanisms for detecting fraudulent use from authorized and unauthorized actors.

20. § 24.2-601. The voting system shall support the inclusion and tabulation of town office elections on general election ballots.

Passed: Yes

Anomalies Reported: None

The EVS 6.0.4.0 system met the following condition(s) of satisfactions:

- ✓ Ballots presented for one or more election scenarios included a town office (or equivalent).
- ✓ Town office (or equivalent) is correctly tabulated and reported with the general election.

The EVS 6.0.4.0 system demonstrated that it supports the inclusion and tabulation of town office elections on General Election ballots.

OFFICE OF THE
GENERAL REGISTRAR

GREG S. RIDDLEMOSER

1300 COURTHOUSE ROAD
P.O. BOX 301
STAFFORD, VIRGINIA 22555-0301



540.658.4000
FAX: 540.658.4003
registrar@staffordcountyva.gov
staffordcountyva.gov/registrar

JUN 13 2019

Chris Piper, Commissioner
Eugene Burton, State Certification Manager
Virginia Department of Elections

(via email)

Gentlemen,

Thank you for the recent invitation and opportunity to assist the State of Virginia's certification of ES&S products after their recent federal (US-EAC) certifications. Your asking me to assist in the last step of certification in Virginia; namely, use in a live election, and giving us the "first look" at that which will be widely deployed later this summer, resulted in great personal pride as well as hundreds of our voters going boffo over their new offerings. My Electoral Board and I cannot wait to field the newest versions in our fall 2019 elections.

You cannot personally keep up with all of the models and exact software version used in every locality. We use the DS200 as our ballot scanner in all of our precincts and our absentee in-person & by-mail operations. We use the ExpressVote as our ADA solution in every precinct. We will update/upgrade all of our equipment to the newest version EVERY time ES&S releases them post-certification. We believe it nothing less than prudent stewardship of our role in the uniquely American critical function of government – conducting efficient, accurate and secure elections. Please approve the certification ASAP.

On Election Day (June 11, 2019) we live-election "tested" Virginia's introduction of the DS450 and ongoing changes to ES&S product line software/firmware for the ExpressVote, DS200, DS450 & DS850. One each of the tabulators and four ExpressVotes were utilized in three precincts (CAP, 303 & 404). All seven (7) machines were L&A by the vendor – overseen by the Electoral Board – after issuing public notice to the parties and candidates. There were no incidents of any kind determined during L&A or Election Day use. The machines worked as predicted and both Stafford and ES&S have retained documentation of the testing and have quarantined the digital media with the Clerk of Court as required.

Should either of you have questions of my Board or I, please feel free to reach out. Additionally, I'd like to be invited to the SBE meeting when this topic appears on their agenda. Thanks again for including us.

Greg S. Riddlemoser
Director of Elections/General Registrar
Former Chairman of the US-EAC Standards Board and Executive Committee
Former Member of the joint US-EAC/US-DOC/NIST-Technical Guidelines Development Committee (TGDC)



STATE CERTIFICATION OF VOTING SYSTEMS

Requirements and Procedures

Revised: April 2012

TABLE OF CONTENTS

Part 1: Introduction	1
1.1. Purpose of Procedures	1
1.2. Specific Requirements.....	1
1.3. Applicability.....	2
1.4. Decertification.....	3
Part 2: Basis for Certification	4
2.1. Federal Compliance Testing.....	4
2.1.1. Voting System Hardware Elements	5
2.1.2. Voting System Software Elements	5
2.1.3. Reciprocity	5
2.2. State Certification Testing.....	5
2.3. Acceptance Tests	6
Part 3: Review and Approval Process	8
3.1. Summary of Process.....	8
3.2. Procedure for Certification	8
3.3. Supporting Information.....	9
3.4. Audit and Validation of Certification.....	13
3.5. Time Frame.....	13
Part 4: Appendix A - Glossary	15
Part 5: Appendix B - Contacts	16

Part 1: Introduction

1.1. Purpose of Procedures

These procedures have been developed and issued as part of a continuing effort to improve the administration of elections in the Commonwealth of Virginia. They provide a formal and organized process for vendors to follow when seeking state certification for a new voting system or an improvement or modification to an existing voting system currently certified for use. To this end the procedures are designed to:

1. Ensure conformity with state election laws relating to the acquisition and use of voting systems and equipment.
2. Provide an organized and consistent means of evaluating and certifying voting systems and equipment marketed by vendors for use in Virginia.
3. Provide an organized and consistent means of evaluating and certifying additional capabilities and changes in the method of operation for voting systems previously certified for use in Virginia.
4. Provide an organized and consistent means of decertifying voting systems and equipment.
5. Provide for the improvement of the electoral process by ensuring that all voting systems operate properly and are installed and tested in compliance with the State Board of Elections approved procedures.
6. Provide for the accurate reporting of all election results for any jurisdiction in which each certified system is used.

1.2. Specific Requirements

1. The voting system or equipment must meet the requirements contained in the most recent version or versions of the Voluntary Voting System Guidelines (VVSG) or Voting System Standards (VSS) currently accepted for testing and certification by the U.S. Election Assistance Commission (EAC). Compliance with the applicable VVSG/VSS may be substantiated through federal certification by the EAC, through certification by another state that requires compliance with the applicable VVSG/VSS, or through testing conducted by a federally certified voting system test laboratory (VSTL) to the standards contained in the applicable VVSG/VSS. Meeting the requirements contained in the VVSG or VSS will substantiate

compliance with the voting system requirements contained in Section 301 of the Help America Vote Act of 2002 (HAVA).

2. A modification to a voting system previously certified by SBE will be tested in a manner necessary to ensure that all changes meet applicable standards and that the modified system (as a whole) will function properly and reliably. If the system being modified has been tested or certified to a previous VVSG/VSS version, SBE may allow testing of modifications to the prior standards or require testing of the modification to the most current standards, at its discretion.
3. The voting system or equipment must comply with the provisions in the *Code of Virginia* relating to voting equipment (Article 3, Chapter 6 of Title 24.2).
4. The voting system or equipment must comply with any applicable regulations or policies issued by the State Board of Elections.
5. The vendor must ensure that the equipment and software can accommodate interactive visual and non-visual presentation of information to voters and alternative languages when required. (See HAVA, 42 USC 15481(a)(3), (4), §203 of the Voting Rights Act (42 USC 1973aa-1a) and Virginia Code Section 24.2-626.1)

1.3. Applicability

1. The procedures outlined in this document are applicable to all voting systems first used on or after the effective date of this document.
2. These procedures are intended to assist local jurisdictions in identifying voting systems that meet all federal and state requirements and are available for purchase based on individual locality requirements.
3. The requirements of these procedures are waived for any voting system or equipment previously certified for and in use in the Commonwealth of Virginia on or before June 28, 2005. The State Board of Elections reserves the right to require re-certification of these systems or equipment at a future date.
4. Any modification to the hardware, firmware, or software of an existing system which has been certified by the State Board of Elections in accordance with these procedures will, in general, invalidate the certification unless it can be determined by the State Board of Elections that the change does not affect the accuracy, reliability, security, usability or accessibility of the system.
5. The intent of these procedures is to ensure that voting system hardware and software have been shown to be reliable, accurate, usable, accessible and capable of secure operation before they are certified for use in the Commonwealth. Hardware and software products with performance proven in commercial applications may be deemed acceptable, provided that they are shown to be compatible with the operational and administrative requirements of the voting environment. Typically, the vendor will be required to provide documentation of a product's proven performance, such as test reports to comparable standards. Products not in wide

commercial use, regardless of their performance histories, will require qualification, certification, and acceptance tests before they can be used. This requirement applies to the operating systems and monitors as well as to the application programs which control and do the work of ballot processing.

1.4. Decertification

The State Board of Elections reserves the right to reexamine and reevaluate any previously certified voting system for any reason, at any time. Any voting system that does not pass certification testing will be decertified. A voting system that has been decertified by SBE may not be used for elections held in the Commonwealth and may not be purchased by localities to conduct elections.

Part 2: Basis for Certification

There are three distinct levels of testing that a voting system must successfully complete before a voting system can be used in the Commonwealth of Virginia. These levels are **Federal Compliance Testing, State Certification Testing, and Acceptance Testing.**

Federal Compliance Testing demonstrates that a voting system complies with the requirements of the most recent version or versions of the VVSG/VSS currently accepted for testing and certification by the EAC. Primary evidence of compliance with these requirements is certification of the system by the EAC. However, federal compliance may also be demonstrated through certification by another state electoral authority that requires compliance with the applicable VVSG/VSS or through testing conducted by a federally certified VSTL to the applicable VVSG/VSS.

State Certification Testing is intended to assure that a voting system complies with the requirements of the Commonwealth of Virginia. State Certification further examines the readiness of a voting system for use under the election management procedures currently in use or proposed for use with the system. State Certification Testing is more specific than Federal Compliance Testing and examines the fit between the voting system and the specific requirements and practices of the Commonwealth.

Acceptance Testing assures that the system delivered is identical to that which was certified and is in good working condition.

2.1. Federal Compliance Testing

Federal Compliance Testing is performed to demonstrate compliance with the most recent version or versions of the VVSG/VSS currently accepted for testing and certification by the EAC. While EAC certification serves as prima facie evidence of compliance, federal compliance may also be demonstrated through certification by another state electoral authority that requires compliance with the applicable VVSG/VSS or through testing conducted by a federally certified VSTL to the applicable VVSG/VSS. SBE will make the final decision on compliance based on all available information. If there is evidence of a material non-compliance, the Commonwealth will work with the vendor to resolve the issue.

To support a review of Federal Compliance Testing, the following documents shall be provided to SBE:

1. A full copy of the Technical Data Package (TDP);
2. A copy of the Test Plan, Test Report and all Test Procedures and Test Cases used by the Voting System Test Lab (VSTL) in performing EAC certification testing or results of testing conducted by a VSTL to the applicable VVSG/VSS outside of the federal certification process;
3. A release to the VSTL to respond to any requests for information from the Commonwealth of Virginia;
4. A release to other states which have certified the system or prior versions of the system to respond to any requests for information from the Commonwealth of Virginia; and

5. Any additional information the State Board of Elections believes is necessary to determine compliance with the applicable Voluntary Voting System Guidelines or Voting System Standards.

2.1.1. Voting System Hardware Elements

All equipment used in a voting system shall be examined to determine its suitability for election use according to the appropriate procedures contained in this document. Equipment to be tested shall be identical in form and function with production units. Engineering or development prototypes are not acceptable.

Modifications to existing hardware that has been previously certified by SBE will invalidate the results of the prior certification unless it can be determined by the State Board of Elections that the change does not affect the accuracy, reliability, security, usability or accessibility of the system.

2.1.2. Voting System Software Elements

Voting system software shall be examined and tested to ensure that it adheres to the performance standards specified in the most recent version or versions of the VVSG/VSS currently accepted for testing and certification by the EAC.

Modifications to existing software that has been previously certified by SBE will invalidate the results of the prior certification unless it can be determined by the State Board of Elections that the change does not affect the accuracy, reliability, security, usability or accessibility of the system.

2.1.3. Reciprocity

The State Board of Elections may accept the qualification tests of the hardware and/or software of a voting system conducted by another state electoral authority that requires compliance with the applicable VVSG/VSS or through testing conducted by a federally certified VSTL to the applicable VVSG/VSS. Any such tests that are accepted may be used to support certification approval in conjunction with, or in lieu of, EAC or State Board of Elections testing. The procedure for transferring qualification tests results from another state or a VSTL is contained in the following sections (see Supporting Information in Part 3). This reciprocity does not, of course, extend to the “Compliance with the *Code of Virginia*” and the “Acceptance Tests” described below since these items are considered unique to Virginia.

2.2. State Certification Testing

State certification testing is intended to verify that the design and performance of the voting system seeking certification complies with all applicable requirements of the *Code of Virginia* and SBE regulations and policies.

The certification test is not intended to result in exhaustive tests of system hardware and software attributes; these are evaluated during federal compliance testing. However, all system functions, which are essential to the conduct of an election, will be evaluated.

An important focus of State Certification Testing is a review of experience with the current and prior versions of the system and the results of other state certification examinations. Any testing and or experiences of other states using the system may be considered. This review requires making inquiries of other users of the system. State certification reports and other evaluations of the system are read and analyzed for insight into the suitability of the system for use in Virginia.

The recommended use procedures are examined along with the voting system to determine how well the system will integrate into Virginia election law and management practices.

Testing is performed to evaluate the system with respect to the specific practices of Virginia.

Testing will evaluate all system operations and procedures which:

- a. Define ballot formats for a primary election and a general election, including all voting options defined by the *Code of Virginia*,
- b. Install application programs and election-specific programs and data in the ballot counting device,
- c. Verify system readiness for operation,
- d. Count ballots,
- e. Perform status tests,
- f. Obtain voting data and audit data reports,
- g. Support recount or election audits, and
- h. Address compliance with physical and language accessibility requirements

The test environment will include the preparation and operation of election and voting databases, and the validation, consolidation, and reporting of administrative and voting data as required by law.

The state may perform hash testing of applications software to verify that the versions provided by the vendor are identical to the versions that have undergone federal compliance testing.

Certification testing will be complete after a successful test use of the equipment in an actual election (*Code of Virginia* §24.2-629 (E)) in one or more local jurisdictions, which have consented to conduct such a test. Successful completion of a test election shall include a post-election audit.

2.3. Acceptance Tests

Acceptance Tests will be conducted by the local jurisdiction, with the assistance of state officials or consultants. Acceptance testing will be performed as part of the procurement process for the voting system.

The local jurisdiction will conduct tests to confirm that the purchased or leased system to be installed is identical to the certified system and that the installed equipment and/or software are fully functional and capable of satisfying the administrative and statutory requirements of the jurisdiction. The state may require localities to perform hash testing of applications software for this purpose. SBE will request that upon acquiring equipment, the locality forwards a letter to SBE confirming that the versions of all software and model(s) of equipment received are identical to the certified system that was ordered.

Typically, the acceptance test will demonstrate the system's ability to execute its designed functionality as advertised and tested, including but not limited to:

- a. Process simulated ballots for each precinct or polling place in the jurisdiction.
- b. Reject overvotes and votes not in valid ballot positions.
- c. Handle write-in votes.

- d. Produce an input to or generate a final report of the election, and interim reports as required.
- e. Generate system status and error messages.
- f. Comply with and enable voter and operator compliance with all applicable procedural, regulatory, and statutory requirements.
- g. Produce an audit log.

Part 3: Review and Approval Process

3.1. Summary of Process

These procedures are limited to those systems and equipment that have passed the prototype stage and are in full production and available for immediate installation and use. A total of six (6) steps have been established to carry out this process. These steps are designed so that the State Board of Elections can, at any point, make a determination to continue the evaluation.

3.2. Procedure for Certification

The evaluation of the voting system will proceed in the following steps:

Step 1: Letter of Request for Certification and Certification Fee

The certification evaluation procedure shall be initiated by a letter from the vendor of the voting system to the Secretary of the State Board of Elections requesting certification for either a specific voting system or for a software, firmware, or hardware modification to a certified voting system. A response letter will be sent to the vendor requesting the certification fee if SBE finds no reason to deny the request for certification based on a preliminary review of the request.

Vendors must pay an initial fee of \$10,000 for new voting system certification requests and \$5,000 for requests for modifications to a previously certified voting system. If SBE's actual costs for reviewing the vendor's submission exceed the amount of the initial fee, the vendor agrees to reimburse SBE for all additional costs incurred. All fees must be collected before certification will be granted.

The Secretary of the State Board of Elections or the Board's representative will notify the vendor of the earliest date after which the requested certification evaluation can begin.

Step 2: Technical Data Package and Corporate Information

The vendor shall submit the Technical Data Package, Corporate Information, and other material described in the next section of this document to an evaluation agent selected by the Commonwealth. The vendor will be supplied with the contact information of the evaluation agent.

The evaluation agent will review the Technical Data Package, Corporate Information, and other materials provided and notify the vendor of any deficiencies. Certification of the voting system will not proceed beyond this step until the Technical Data Package and Corporate Information are complete.

Step 3: Preliminary Review

The evaluation agent will conduct a preliminary analysis of the Technical Data Package, Corporate Information, and other materials provided and prepare an Evaluation Proposal containing the following information:

1. Components of the voting system requiring evaluation.

2. Identification of any additional materials needed to ascertain financial stability and capabilities of the vendor to maintain support of the voting system.
3. Description of the activities required to complete the portion of the evaluation performed by the evaluation agent.
4. Estimate of time required to complete the portion of the evaluation performed by the evaluation agent.

Step 4: Authorization to Proceed

The vendor will review the Evaluation Proposal and notify the Secretary of the State Board of Elections, in writing, of the desire to continue or terminate the evaluation process. A copy of this notification will be sent to the evaluation agent.

Step 5: Evaluation

The vendor will arrange for any “Non-operating, Environmental” testing if required and submit the results of these tests to the evaluation agent. After any required “Non-operating, Environmental” tests have been successfully completed, the evaluation agent will conduct the evaluation described in the Evaluation Proposal and submit a report of the findings to the State Board of Elections.

Step 6: Test Election

The State Board of Elections will supervise a test use of the system in an actual election with the vendor present prior to final certification.

Step 7: Certification

Based on the information contained in the report from the evaluation agent, the test election, and any other information in their possession, the State Board of Elections will determine whether the proposed voting system will be certified for use in the Commonwealth of Virginia and notify the vendor of the decision.

3.3. Supporting Information

Request for Certification

The request to begin the certification process for a voting system shall be a letter addressed to:

Secretary of the State Board of Elections
1100 Bank Street, 1st Floor
Richmond, Virginia 23219

This request shall be signed by a company officer and contain the following information:

1. Identification of the specific voting system to be evaluated for certification. Each different voting system or version of a voting system requires a separate request for certification. Each component of the hardware, firmware, and software must be identified by version number.

2. Copies of documents substantiating completion of federal compliance testing, including whether the proposed voting system has been certified under the most recent version or versions of the VVSG/VSS currently accepted for testing and certification by the EAC in another state or by a VSTL.
3. Whether the proposed voting system has ever been denied certification or had certification withdrawn in any state or by the EAC.
4. A brief overview description of the voting system. Typical marketing brochures are usually sufficient for this description.
5. Whether the proposed voting system or a version of the proposed voting system is currently used in Virginia or elsewhere. (List all locations where the system is used.)
6. A check or money order for the non-refundable certification fee must be included with this request before any certification work begins.

Technical Data Package

Before evaluation can begin, the vendor must submit to the evaluation agent a Technical Data Package. Each item in the package must be clearly identified; if the TDP is incomplete or the items in the package are not clearly identified, the entire package may be returned to the vendor and the evaluation of the voting system rescheduled.

The *Technical Data Package* must contain the following items, if they were not included in the TDP submitted to the VSTL:

1. *Hardware Schematic Diagrams.* Schematic diagrams of all hardware.
2. *Hardware Theory of Operations.* Documentation describing the theory of operation of the hardware.
3. *Customer Maintenance Documentation.* Documentation describing any maintenance that the vendor recommends can be performed by a customer with minimal knowledge of the system.
4. *Operations Manual.* Operations documentation that is normally supplied to the customer for use by the person(s) who will operate the equipment.
5. *Recommended Use Procedures.* Specific election administration procedures recommended for use with the system.
6. *Software License Agreement.* The software license agreement must be perpetual. An annual renewable support fee may be included as an option.
7. *Software Source Code.* Source code of the software and firmware is not required if it was submitted pursuant to federal certification. SBE may, at its discretion, request

copies of the source code if the system has not been certified by the EAC. *{If source code is required to be submitted, it shall be supplied in the form of a listing and in a machine-readable form on media that is readable by the voting system. If there is any chance of ambiguity, the required compiler must be specified.}*

8. *Software System Design.* Documentation describing the logical design of the software. This documentation should clearly indicate the various modules of the software, their functions, and their interrelationships with each other. The minimum acceptable documentation is a system flowchart.
9. *Customer Documentation.* A complete set of all documentation which is available to the purchaser/user of the voting system. Clearly identify the documentation which is included in the cost of the system and the documentation which is available for an additional charge.
10. *Standard Contract.* Statement of deliverables to include: verification statement that equipment purchased is identical to equipment certified by the State Board of Elections, software licenses, warranties, support services provided, etc.
11. *Warranty.* The period and extent of the warranty and the method of repair/replacement for all hardware items; the circumstances under which equipment is replaced rather than repaired and the method by which a user requests such replacement; additional warranties that are available over and above the standard warranty, what these warranties cover, and their costs; the period and extent of warranty and the method of correction or replacement for all software provided as part of the voting system; and the technical documentation provided with all hardware and software that is used to certify that the individual component will perform in the manner and for the specified time.
12. *Test Data/Software (Optional).* Any available test data, ballot decks, and/or software that can be used to demonstrate the various functions of the voting system or verify that the version of the applications submitted are identical to the versions that have undergone federal compliance testing (i.e. hash testing tools). Although optional, these items can significantly reduce the effort, and hence the time and cost, involved in the evaluation of the system.
13. *Recommended Security Practices.* Documentation of the practices recommended by the vendor to ensure the optimum security and functionality of the system.

If the voting system is certified, the State Board of Elections will retain the Technical Data Package as long as the voting system is marketed or used in the Commonwealth of Virginia.

Transfer of Certification (Reciprocity)

If the voting system has successfully completed qualification testing by the EAC or another state, the State Board of Elections may accept the results of those tests. In this case, the Technical Data Package shall contain the following item in addition to the items described above:

Qualification Test Report. A certified copy of the results of the evaluation of the voting system under the most recent version or versions of the VVSG/VSS currently accepted for testing and certification by the EAC. This report must clearly identify the system evaluated, specifying the version numbers of all components of the hardware, firmware, and software. The evaluation report or an accompanying letter shall identify the state for which the evaluation was performed, the responsible state official, the organization conducting the evaluation, and the individual responsible for the evaluation. This report must be sent to the State Board of Elections directly from the organization which conducted the evaluation.

Corporate Information

Before evaluation can begin, the vendor must submit to the evaluation agent the Corporate Information as detailed below with each item clearly identified. If the Corporate Information is incomplete or the items in the package are not clearly identified, the entire package may be returned to the vendor and evaluation of the voting system rescheduled.

The Corporate Information shall contain the following items:

1. History and description of the business including year established, products and services offered, areas served, branch offices and subsidiary and/or parent companies.
2. Management and staff organization, number of full time employees by category, number of part-time employees by category, resumes of key employees who will assist Virginia localities in acquiring the system if it is authorized for use.
3. Audited Report of the business' most current fiscal year. Multiple reports may need to be submitted depending on the business' fiscal calendar and the length of time to complete the certification process. Certification can take as long as a year.
4. Comfort letter from the business' primary bank. If the business uses more than one, multiple comfort letters must be submitted.
5. Financial history of the business including a financial statement for the past three (3) fiscal years. If the vendor is not the manufacturer of the equipment for which application is made, include a financial statement for the manufacturer for the past three (3) fiscal years.
6. Gross sales in voting products and services for the past three (3) years and the percent that is representative of the total sales of the business and its subsidiaries.
7. The location and manufacturing capability of each manufacturing facility that is used to fabricate and assemble all or any component part of the voting and/or tabulating system being submitted for certification.
8. The location and servicing capability of each service facility that will be used to service the voting and/or counting system for certification and the service limitation of the facility.

9. If publicly traded, indexes rating the business debt.
10. Quality assurance process used in the manufacturing of the voting system.
11. Configuration management process used with the voting system.

If the voting system is certified, the State Board of Elections will retain the Corporate Information as long as the voting system is marketed or used in Virginia.

Proprietary Information

The vendor must clearly mark any information it requests be treated as confidential and proprietary before providing it to Virginia representatives for evaluation. It is not sufficient to simply state that everything is proprietary. Every page of documentation that contains information the vendor considers proprietary information must be clearly marked. The State Board of Elections cannot guarantee the extent to which any material provided will be exempt from disclosure in litigation or otherwise.

3.4. Audit and Validation of Certification

It is the responsibility of both the vendor and the local jurisdiction to ensure that a voting system that is supplied or purchased for use in the Commonwealth of Virginia has been certified by the State Board of Elections. It is the responsibility of the vendor to submit any modifications to a previously certified voting system to the State Board of Elections for review.

If any question arises involving the certification of a voting system in use in Virginia, the hardware and software system verification tools will be used to verify that the voting system in use is in fact identical to the voting system that was submitted for certification. Any unauthorized modifications to a certified system may result in decertification of the system by SBE or bar a voting system vendor from receiving certification of voting systems in the future.

3.5. Time Frame

The State Board of Elections reserves the right to terminate the certification process at any time if the vendor fails to proceed in a timely manner. In particular, if a period of three months expires between any request for information by the Board or its evaluation agent and the vendor's response to that request, the Board will terminate the certification process. If the certification process is terminated under this provision, the vendor will forfeit any fees received by SBE. Any certification process terminated under this provision must be re-initiated from Step 1, Section 3.2: Procedure for Certification.

The certification process is also terminated when:

- a. SBE issues a determination regarding certification;
- b. The Vendor withdraws from the process; or
- c. The system fails the certification test.

The process can only be re-initiated from Step 1, Section 3.2: Procedure for Certification, if the process is terminated under conditions b. or c.

Part 4: Appendix A - Glossary

The following terms are defined in SBE Policy 2009-001, Voting Equipment Security.

Acceptance Testing - The purpose of acceptance testing is to demonstrate and confirm to the greatest extent possible that the voting systems purchased or leased by a local jurisdiction are identical to the voting systems certified by the State Board of Elections and that the voting systems equipment and software are fully functional and capable of satisfying the administrative and statutory requirements of the local jurisdiction. Acceptance testing is conducted when voting systems are initially received by the local electoral board from a vendor or other outside source (e.g., another local jurisdiction).

Certification Testing - The purpose of certification testing is to verify that the design and performance of the voting system being tested comply with all of the requirements of the *Code of Virginia*. Certification testing is not intended to exhaustively test all of the voting system hardware and software attributes; these are evaluated during qualification testing. However, all voting system functions, that are essential to the conduct of an election, are evaluated.

Evaluation Agent – An independent outside consultant selected by the State Board of Elections to conduct certification testing of voting systems.

Qualification Testing - The purpose of qualification testing is to demonstrate that the voting system complies with the requirements of its own design specifications. This testing encompasses selective in-depth examination of software; inspection and evaluation of voting system documentation; tests of hardware under conditions simulating the intended storage, operation, transportation, and maintenance environments; and tests to verify system performance and function under normal and abnormal operating conditions. Qualification testing is normally conducted by a Voting System Test Laboratory (VSTL).

Voting System - The term “voting system” refers to the total combination of mechanical, electro-mechanical and electronic equipment (including the software, firmware, and documentation required to program, control, and support the equipment) that is used to: define ballots; verify voter registration; cast and count votes; report or display election results; recount votes or produce audit records or support election recounts or audits; and to maintain and produce any review trail information; and the practices and associated documentation used to: identify voting system components and versions of such components; test the system during its development and maintenance; maintain records of system errors and defects; to determine specific system changes to be made a system after the initial qualification of the system; and make available any materials to the voter (such as notices, instructions, forms, or paper ballots).

Voting System Test Laboratory (VSTL): Test laboratory accredited by the National Voluntary Laboratory Accreditation Program (NVLAP) to be competent to test voting systems. When NVLAP has completed its evaluation of a test lab, the Director of NIST will forward a recommendation to the EAC for the completion of the accreditation process.

Part 5: Appendix B - Contacts

The State Board of Elections

Eugene Burton, Voting Technology Coordinator

Telephone: (804) 864-8912

Karen Thomas, Deputy CIO

Telephone: (804) 774-4685

Address: 1100 Bank Street, 1st Floor
Richmond, Virginia 23219-3497



★ VIRGINIA ★
STATE BOARD *of* ELECTIONS

2020 Independent and 3rd Party Presidential Candidate Petitions

BOARD WORKING PAPERS
Samantha Buckley
Policy Analyst



★ VIRGINIA ★
STATE BOARD *of* ELECTIONS

Memorandum

To: Chairman Brink, Vice Chair O'Bannon, and Secretary LeCruise
From: Samantha Buckley, Policy Analyst
Date: August 6, 2019
Re: Amendments to the Petition of Qualified Voter for Electors for President and Vice President

Suggested motion for a Board member to make:

Move that the Board approve the amendments to the Petition of Qualified Voter for Electors for President and Vice President.

Applicable Code Sections: Va. Code § 24.2-543

Attachments:

Your Board materials include the following:

- Proposed Petition of Qualified Voter for Electors for President and Vice President (letter size)
- Proposed Petition of Qualified Voter for Electors for President and Vice President (legal size)

Background:

The proposed amendments to the Petition of Qualified Voter for Electors for President and Vice President updates the date petitions may be circulated, the date of the November General Election for 2020, and amends information on each petition to ensure the letter and legal size have duplicate information.

ELECT staff recommendation:

ELECT staff recommends the Board approve the amendments to the Petition of Qualified Voter for Electors for President and Vice President.

WHEN A CONGRESSIONAL DISTRICT INCLUDES MORE THAN ONE COUNTY OR CITY, IT IS SUGGESTED THAT YOU USE A SEPARATE PETITION FORM FOR QUALIFIED VOTERS IN EACH COUNTY OR CITY. IT ALSO IS SUGGESTED THAT YOU FILE PETITIONS IN COUNTY/CITY ORDER TO FACILITATE THE PROCESSING OF THE FILING.

IF YOU TRACK THE NUMBER OF SIGNATURES BY CONGRESSIONAL DISTRICT, ENTER DISTRICT NUMBER: _____ [OPTIONAL]

**COMMONWEALTH OF VIRGINIA
PETITION OF QUALIFIED VOTERS FOR ELECTORS FOR PRESIDENT AND VICE PRESIDENT**

We, the qualified voters of _____ in the Commonwealth of Virginia signed
ENTER COUNTY OR CITY NAME

hereunder or on the reverse side of this page, do hereby petition the following to become candidates for the office of Elector for President and Vice President of the United States at the General Election to be held on November 3, 2020.

CONGRESSIONAL DISTRICT:

1 st	8 th
2 nd	9 th
3 rd	10 th
4 th	11 th
5 th	AT LARGE
6 th	AT LARGE
7 th	

The above candidates, if elected, are required to vote in the Electoral College for _____ for President and _____ for Vice President. We further petition that the names of these candidates be identified on the ballot under the Party name of _____, a group qualified pursuant to § 24.2-543 of the Code of Virginia.

[IF ELECTORS DO NOT REPRESENT A PARTY GROUP, THEY WILL BE DESIGNATED "INDEPENDENT".]

CIRCULATOR: MUST SWEAR OR AFFIRM IN THE AFFIDAVIT ON THE REVERSE SIDE OF THIS FORM THAT S/HE IS: (A) A LEGAL RESIDENT OF THE UNITED STATES OF AMERICA, NOT A MINOR NOR A FELON WHOSE VOTING RIGHTS HAVE NOT BEEN RESTORED OR (B) A CONSTITUTIONAL QUALIFIED CANDIDATE FOR PRESIDENT, AND THAT S/HE PERSONALLY WITNESSED EACH SIGNATURE.

SIGNER: YOUR SIGNATURE ON THIS PETITION MUST BE YOUR OWN AND DOES NOT SIGNIFY AN INTENT TO VOTE FOR THE CANDIDATE. YOU MAY SIGN PETITIONS FOR MORE THAN ONE CANDIDATE.

OFFICE USE ONLY <input type="checkbox"/> ▼	SIGNATURE OF REGISTERED VOTER [PRINT NAME IN SPACE BELOW SIGNATURE]	POST OFFICE BOXES ARE NOT ACCEPTABLE RESIDENT ADDRESS House Number and Street Name or Rural Route and Box Number and City/Town	DATE SIGNED [Must be on or after January 1, 2020]	*SEE NOTE BELOW DATE OF BIRTH [OPTIONAL]
1.	SIGN	RESIDENCE		
	PRINT	CITY/TOWN		
2.	SIGN	RESIDENCE		
	PRINT	CITY/TOWN		
3.	SIGN	RESIDENCE		
	PRINT	CITY/TOWN		
4.	SIGN	RESIDENCE		
	PRINT	CITY/TOWN		

CONTINUE ADDITIONAL SIGNATURES AND COMPLETE AFFIDAVIT ON REVERSE SIDE

***Privacy Notice:** The date of birth is part of each voter's official record and is requested only to make it possible to check this petition more quickly and with greater accuracy. It is not mandatory that it be provided and you may sign the petition without doing so. The Department of Elections, when copying this document for public inspection, must cover the month and day of the date of birth.

NOTICE: Candidates for Elector for President and Vice President may provide their Candidate Qualifications directly to the Department of Elections, Washington Building, 1100 Bank Street, First Floor, Richmond, Virginia 23219.

All signatures required by law need not be on the same page of the petition. Numerous pages may be circulated. The circulator also must swear or affirm in the affidavit that s/he personally witnessed the signature of each voter.

CIRCULATOR: MUST SWEAR OR AFFIRM IN THE AFFIDAVIT BELOW THAT S/HE IS: (A) A LEGAL RESIDENT OF THE UNITED STATES OF AMERICA, NOT A MINOR NOR A FELON WHOSE VOTING RIGHTS HAVE NOT BEEN RESTORED OR (B) A CONSTITUTIONALLY QUALIFIED CANDIDATE FOR PRESIDENT, AND THAT S/HE PERSONALLY WITNESSED EACH SIGNATURE.

SIGNER: YOUR SIGNATURE ON THIS PETITION MUST BE YOUR OWN AND DOES NOT SIGNIFY AN INTENT TO VOTE FOR THE CANDIDATE. YOU MAY SIGN PETITIONS FOR MORE THAN ONE CANDIDATE.

OFFICE USE ONLY ▼	SIGNATURE OF REGISTERED VOTER [PRINT NAME IN SPACE BELOW SIGNATURE]	POST OFFICE BOXES ARE NOT ACCEPTABLE RESIDENT ADDRESS House Number and Street Name or Rural Route and Box Number and City/Town	DATE SIGNED [Must be on or after January 1, 2020]	*SEE NOTE BELOW DATE OF BIRTH [OPTIONAL]
5.	SIGN	RESIDENCE		
	PRINT	CITY/TOWN		
6.	SIGN	RESIDENCE		
	PRINT	CITY/TOWN		
7.	SIGN	RESIDENCE		
	PRINT	CITY/TOWN		
8.	SIGN	RESIDENCE		
	PRINT	CITY/TOWN		
9.	SIGN	RESIDENCE		
	PRINT	CITY/TOWN		
10.	SIGN	RESIDENCE		
	PRINT	CITY/TOWN		
11.	SIGN	RESIDENCE		
	PRINT	CITY/TOWN		

Commonwealth of Virginia

- AFFIDAVIT -

I, _____, swear or affirm that (i) my full residential address is

_____ ; (ii) I am either (a) a legal resident of the United States of America in the State/Commonwealth of _____; who is not a minor nor a felon whose voting rights have not been restored or (b) a constitutionally qualified candidate for President of the United States who is circulating her/his own petition, and (iii) I personally witnessed the signature of each person who signed this page or its reverse side. I understand that falsely signing this affidavit is a felony punishable by a maximum fine up to \$2,500 and/or imprisonment up to ten years.

PLACE PHOTOGRAPHICALLY REPRODUCIBLE NOTARY SEAL/STAMP BELOW

SIGNATURE OF PERSON CIRCULATING THE PETITION

DATE _____ CIRCULATOR'S LAST 4 DIGITS OF SOCIAL SECURITY NUMBER

State of _____ County/City of _____

The foregoing instrument was subscribed and sworn before me this _____ day of _____, 20____, by

PRINT NAME OF PERSON CIRCULATING THE PETITION

SIGNATURE OF NOTARY OR OTHER PERSON AUTHORIZED TO ADMINISTER OATHS NOTARY REGISTRATION NUMBER** DATE NOTARY COMMISSION EXPIRES**

***Privacy Notice:** The date of birth is part of each voter's official record and is requested only to make it possible to check this petition more quickly and with greater accuracy. It is not mandatory that it be provided and you may sign the petition without doing so. The Department of Elections, when copying this document for public inspection, must cover the month and day of the date of birth.

***Fraud Notice:** Any willfully false material statement or entry made on this form by any person shall constitute the crime of election fraud and be punishable as a Class 5 felony.

WHEN A CONGRESSIONAL DISTRICT INCLUDES MORE THAN ONE COUNTY OR CITY, IT IS SUGGESTED THAT YOU USE A SEPARATE PETITION FORM FOR QUALIFIED VOTERS IN EACH COUNTY OR CITY. IT ALSO IS SUGGESTED THAT YOU FILE PETITIONS IN COUNTY/CITY ORDER TO FACILITATE THE PROCESSING OF THE FILING.
IF YOU TRACK THE NUMBER OF SIGNATURES BY CONGRESSIONAL DISTRICT, ENTER DISTRICT NUMBER: _____ [OPTIONAL]

**COMMONWEALTH OF VIRGINIA
PETITION OF QUALIFIED VOTERS FOR ELECTORS FOR PRESIDENT AND VICE PRESIDENT**

We, the qualified voters of _____ in the Commonwealth of Virginia signed
ENTER COUNTY OR CITY NAME

hereunder or on the reverse side of this page, do hereby petition the following to become candidates for the office of Elector for President and Vice President of the United States at the General Election to be held on November 3, 2020.

CONGRESSIONAL DISTRICT:

1 st	8 th
2 nd	9 th
3 rd	10 th
4 th	11 th
5 th	AT LARGE
6 th	AT LARGE
7 th	

The above candidates, if elected, are required to vote in the Electoral College for _____ for President and _____ for Vice President. We further petition that the names of these candidates be identified on the ballot under the Party name of _____, a group qualified pursuant to § 24.2-543 of the Code of Virginia. [IF ELECTORS DO NOT REPRESENT A PARTY GROUP, THEY WILL BE DESIGNATED "INDEPENDENT".]

CIRCULATOR: MUST SWEAR OR AFFIRM IN THE AFFIDAVIT ON THE REVERSE SIDE OF THIS FORM THAT S/HE IS EITHER (A) A LEGAL RESIDENT OF THE UNITED STATES OF AMERICA WHO IS NOT A MINOR NOR A FELON WHOSE VOTING RIGHTS HAVE NOT BEEN RESTORED OR (B) A CONSTITUTIONALLY QUALIFIED CANDIDATE FOR PRESIDENT, AND THAT S/HE PERSONALLY WITNESSED EACH SIGNATURE.
SIGNER: YOUR SIGNATURE ON THIS PETITION MUST BE YOUR OWN AND DOES NOT SIGNIFY AN INTENT TO VOTE FOR THE CANDIDATE. YOU MAY SIGN PETITIONS FOR MORE THAN ONE CANDIDATE.

OFFICE USE ONLY <input type="checkbox"/>	SIGNATURE OF REGISTERED VOTER [PRINT NAME IN SPACE BELOW SIGNATURE]	POST OFFICE BOXES ARE NOT ACCEPTABLE RESIDENT ADDRESS House Number and Street Name or Rural Route and Box Number and City/Town	DATE SIGNED [Must be on or after January 1, 2020]	*SEE NOTE BELOW LAST 4 DIGITS OF SOCIAL SECURITY NUMBER [OPTIONAL]
1.	SIGN	RESIDENCE		
	PRINT	CITY/TOWN		
2.	SIGN	RESIDENCE		
	PRINT	CITY/TOWN		
3.	SIGN	RESIDENCE		
	PRINT	CITY/TOWN		
4.	SIGN	RESIDENCE		
	PRINT	CITY/TOWN		
5.	SIGN	RESIDENCE		
	PRINT	CITY/TOWN		
6.	SIGN	RESIDENCE		
	PRINT	CITY/TOWN		
7.	SIGN	RESIDENCE		
	PRINT	CITY/TOWN		
8.	SIGN	RESIDENCE		
	PRINT	CITY/TOWN		
9.	SIGN	RESIDENCE		
	PRINT	CITY/TOWN		

CONTINUE ADDITIONAL SIGNATURES AND COMPLETE AFFIDAVIT ON REVERSE SIDE

*Privacy Notice: The last four digits of the social security number is part of each voter's official record and is requested only to make it possible to check this petition more quickly and with greater accuracy. It is not mandatory that it be provided and you may sign the petition without doing so. The State Board of Elections, when copying this document for public inspection, must cover the column containing the last four digits of the social security number.

All signatures required by law need not be on the same page of the petition. Numerous pages may be circulated. The circulator also must swear or affirm in the affidavit that s/he personally witnessed the signature of each voter.

CIRCULATOR: MUST SWEAR OR AFFIRM IN THE AFFIDAVIT BELOW THAT S/HE IS EITHER (A) A LEGAL RESIDENT OF THE UNITED STATES OF AMERICA WHO IS NOT A MINOR NOR A FELON WHOSE VOTING RIGHTS HAVE NOT BEEN RESTORED OR (B) A CONSTITUTIONALLY QUALIFIED CANDIDATE FOR PRESIDENT, AND THAT S/HE PERSONALLY WITNESSED EACH SIGNATURE.

SIGNER: YOUR SIGNATURE ON THIS PETITION MUST BE YOUR OWN AND DOES NOT SIGNIFY AN INTENT TO VOTE FOR THE CANDIDATE. YOU MAY SIGN PETITIONS FOR MORE THAN ONE CANDIDATE.

OFFICE USE ONLY ▼	SIGNATURE OF REGISTERED VOTER [PRINT NAME IN SPACE BELOW SIGNATURE]	POST OFFICE BOXES <u>ARE NOT ACCEPTABLE</u> RESIDENT ADDRESS House Number and Street Name or Rural Route and Box Number and City/Town	DATE SIGNED [Must be on or after January 1, 2020]	*SEE NOTE BELOW LAST 4 DIGITS OF SOCIAL SECURITY NUMBER [OPTIONAL]
10.	SIGN	RESIDENCE		
	PRINT	CITY/TOWN		
11.	SIGN	RESIDENCE		
	PRINT	CITY/TOWN		
12.	SIGN	RESIDENCE		
	PRINT	CITY/TOWN		
13.	SIGN	RESIDENCE		
	PRINT	CITY/TOWN		
14.	SIGN	RESIDENCE		
	PRINT	CITY/TOWN		
15.	SIGN	RESIDENCE		
	PRINT	CITY/TOWN		
16.	SIGN	RESIDENCE		
	PRINT	CITY/TOWN		
17.	SIGN	RESIDENCE		
	PRINT	CITY/TOWN		
18.	SIGN	RESIDENCE		
	PRINT	CITY/TOWN		
19.	SIGN	RESIDENCE		
	PRINT	CITY/TOWN		
20.	SIGN	RESIDENCE		
	PRINT	CITY/TOWN		
	PRINT	CITY/TOWN		

Commonwealth of Virginia

- AFFIDAVIT -

I, _____, swear or affirm that (i) my resident address is _____; (ii) I am either (a) a legal resident of the United States of America in the state/commonwealth of _____ who is not a minor nor a felon whose voting rights have not been restored or (b) a constitutionally qualified candidate for President of the United States who is circulating her/his own petition, and (iii) I personally witnessed the signature of each person who signed this page or its reverse side. I understand that falsely signing this affidavit is a felony punishable by a maximum fine up to \$2,500 and/or imprisonment up to ten years.

PLACE PHOTOGRAPHICALLY REPRODUCIBLE
NOTARY SEAL/STAMP BELOW

SIGNATURE OF PERSON CIRCULATING THE PETITION

CIRCULATOR'S LAST 4
DIGITS OF SOCIAL
SECURITY NUMBER

State of _____ County/City of _____

The foregoing instrument was subscribed and sworn before me this
_____ day of _____, 20____, by

PRINT NAME OF PERSON CIRCULATING THE PETITION

SIGNATURE OF NOTARY OR OTHER PERSON AUTHORIZED TO ADMINISTER OATHS

NOTARY REGISTRATION NUMBER**

DATE NOTARY COMMISSION EXPIRES**

***Privacy Notice:** The last four digits of the social security number is part of each voter's official record and is requested only to make it possible to check this petition more quickly and with greater accuracy. It is not mandatory that it be provided and you may sign the petition without doing so. The State Board of Elections, when copying this document for public inspection, must cover the column containing the last four digits of the social security number.

** If not included in seal/stamp.



★ VIRGINIA ★
STATE BOARD *of* ELECTIONS

1 VAC 20-90-20 REPEAL

BOARD WORKING PAPERS
Arielle A. Schneider
Policy Analyst



★ VIRGINIA ★
DEPARTMENT *of* ELECTIONS

Memorandum

To: State Board of Elections
From: Arielle A. Schneider, Policy Analyst
Date: August 6, 2019
Re: Repeal of 1 VAC 20-90-20

Suggested Motion

I move that the Board repeal 1 VAC 20-90-20 pursuant to the Administrative Procedure Act.

Background

1 VAC 20-90-20 provides campaign committees the option of submitting a nonelectronic campaign finance report to the State Board of Elections. 1 VAC 20-90-20 also provides that a \$25 administrative fee must be submitted for each nonelectronic report, and suggests that Department of Elections staff will manually transfer the information from a nonelectronic report into the electronic reporting system on behalf of the campaign committee.

This regulation was promulgated when submitting campaign finance reports electronically was optional. Subsequent changes to the Code of Virginia 24.2-947.5 now require candidates for statewide office, the General Assembly, and candidates for local or constitutional office in any locality with a population of more than 70,000 persons to file reports “by computer or electronic means in accordance with the standards approved by the State Board.”

1 VAC 20-90-20 offers an option (to file by paper) that the Code of Virginia does not provide to candidates required to file with the State Board of Elections. Accordingly, the regulation pertains to law that no longer exists, and offers an option not contemplated by the current Code of Virginia. 1 VAC 20-90-20 should be repealed.

Regulatory Process

Due to the nature of this repeal, the Department of Elections proposes this regulatory change be fast-tracked according to the Code of Virginia 2.2-4012.1, which provides that rules expected to be noncontroversial may be repealed via the fast-track regulatory process. This process requires the concurrence of the Governor, written notice to the applicable standing committees of the Senate of Virginia and the House of Delegates, and to the Joint Commission on Administrative Rules prior to submitting a fast-track regulation. The fast-track regulation would be published in the Virginia Register of Regulations and posted on the Virginia Regulatory Town Hall to allow public comment. If an objection to the use of the fast-track processes is received within the public comment period from 10 or more persons, any member of the applicable standing committee of either house of the General Assembly or of the Joint Commission on Administrative Rules, the

agency shall file notice of the objection with the Registrar of Regulations and proceed with the normal promulgation process with the initial publication of the fast-track regulation serving as the Notice of Intended Regulatory Action. Otherwise, the regulation is repealed 15 days after the close of the comment period.

Regulation Text

1 VAC 20-90-20: Any campaign committee that files a nonelectronic, campaign finance report with the State Board of Elections under § 24.2-947.5 of the Code of Virginia shall pay a \$25 administrative fee per report to the State Board of Elections. Such payment shall be due by the filing deadline for the report or upon filing the report, whichever is later. Any committee that is indigent may request a waiver from the State Board of Elections.



★ VIRGINIA ★
STATE BOARD *of* ELECTIONS

Stand by Your Ad

BOARD WORKING PAPERS
Arielle A. Schneider
Policy Analyst



★ VIRGINIA ★
DEPARTMENT *of* ELECTIONS

Stand By Your Ad

August 6, 2019

State Board of Elections Meeting

Print Media

1. Corbo for School Board CC-19-00391
2. David F. Williams
3. Donald Smith for Sheriff CC-15-00114
4. Dwayne T. Wade CC-19-00772
5. Galvin for Delegate CC-19-00330
6. Gwen for Office CC-19-00683
7. Elect Kenya Savage – At Large Candidate CC-19-00294
8. Friends of Levin White 2019 CC-18-00282
9. Lloyd Banks
10. Patrick “Pat” Saylor
11. Friends of Rich Breeden LLC CC-18-00577
12. Friends of Scott Wyatt. CC-19-00177
13. Virginia Constitutional Conservatives PAC-17-00698

Advertisement, 24.2-955.1

“Advertisement means any message appearing in the print media, on television, or on radio that constitutes a contribution or expenditure under Chapter 9.3”

Contribution or Expenditure, 24.2-945.1

“Contribution means money and services of any amount, in-kind contribution, and any other thing of value, given, advanced, loaned, or in any other way provided to a candidate, campaign committee, political committee, or person for the purpose of expressly advocating the election or defeat of a clearly identified candidate ... Contribution includes money, services, or things of value in any way provided by a candidate to his own campaign ...”

“Expenditure means money and services of any amount, and any other thing of value, paid, loaned, provided or in any other way disbursed by any candidate, campaign committee, political committee, or person for the purpose of expressly advocating the election or defeat of a clearly identified candidate ...”

Candidate, 24.2-101

“Candidate means a person who seeks or campaigns for an office of the Commonwealth or one of its governmental units in a general, primary, or special election and who is qualified to have his name placed on the ballot. ...

For the purposes of Chapters 9.3 and 9.5, “candidate” shall include any person who raises or spends funds in order to seek or campaign for an office of the Commonwealth, excluding federal offices, or one of its governmental units in a party nomination process or general, primary, or special election; and such person shall be considered a candidate until a final report is filed pursuant to Article 8 of Chapter 9.3.”

Express Advocacy

Express Advocacy – A direct or indirect contribution, in-kind contribution, independent expenditure or loan made to a candidate or political committee for the purpose of influencing the outcome of an election; *an advertisement that refers to a party or candidate(s) by name and states “Vote for...”; “Support”; “Elect...”; “Smith for Congress”; “Send Him Home”; “Oppose”, etc.*

Schedule of Penalties *candidates for General Assembly or local candidates*

Section 15.3 - Penalties for Candidates for General Assembly or Local Office

The following penalties will apply only to General Assembly or local candidates and/or their campaign committees which sponsor political advertisements.

Print Media

Violators shall be assessed a penalty as follows:

- \$50 for a first time violation with explanation, apology and/or remedial measures taken
- \$100 for a first time violation without explanation, apology and/or remedial measures taken
- \$250 for any second violation
- \$500 for any third violation
- \$1000 for any fourth or subsequent violation

If the advertisement is disseminated or on display in the 14 days prior to or on the Election Day for which the advertisement pertains, the above penalties will be doubled and the maximum penalty would be \$2,500.

1. Corbo for School Board CC-19-00391

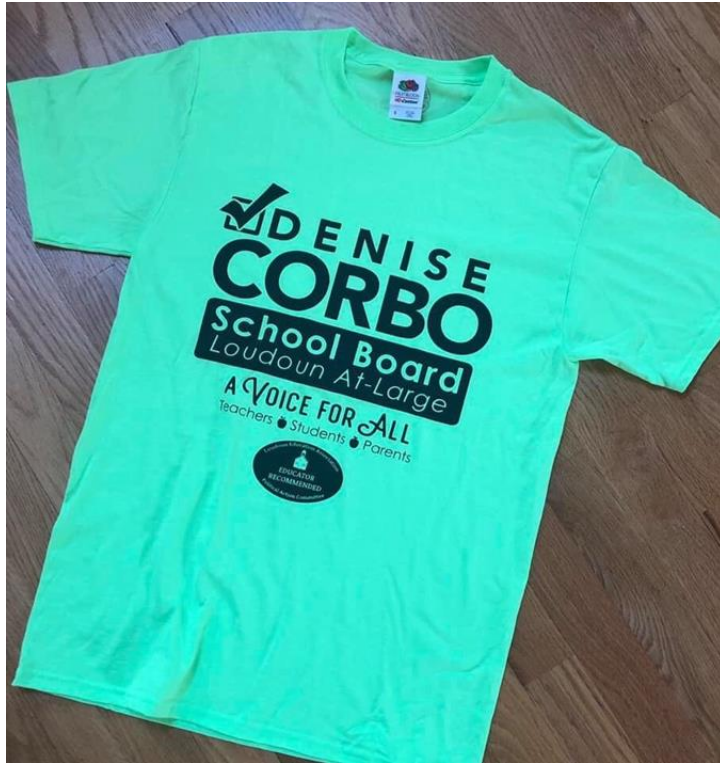

Two violations in this picture.
BOTH the Printed shirts and Banners do NOT have the proper disclaimer on them.



COMMONWEALTH of VIRGINIA
DEPARTMENT OF ELECTIONS

Christopher E. "Chris" Piper
Commissioner

Jessica N. Bowman
Deputy Commissioner

July 23, 2019

Corbo for School Board CC-19-00391
42437 Holly Knoll Court
Ashburn, Virginia 20148

Dear Corbo for School Board:

The State Board of Elections is in receipt of a complaint regarding a possible violation of Virginia's Stand by Your Ad law (Chapter 9.5 of Title 24.2 of the Code of Virginia) by Corbo for School Board CC-19-00391. A copy of the challenged advertisement is included with this letter.

The State Board of Elections is holding a public meeting on Tuesday, August 6, 2019 at 1:00 P.M. to determine whether a violation has occurred and whether to impose civil penalties. You or a representative may attend and/or provide additional information to the Board that may be helpful in regarding this matter. You may also email a response to the complaint and/or information you would like the Board to consider to the Department of Elections Campaign Finance team at CFDA@elections.virginia.gov.

For more information about how the State Board of Elections adjudicates complaints regarding campaign advertisements, please refer to SBE Policy 2018-001, available online on the Department of Elections website:
<https://www.elections.virginia.gov/media/formswarehouse/Board-Policies/SBE-Policy-2018-001-StandByYourAdHearings.pdf>.

The meeting will be held in Senate Room 3 in the Virginia State Capitol, located at 1000 Bank St, Richmond, Virginia, 23219. To get to Senate Room 3, please enter through the main entrance to the Capitol building on Bank Street.

The Code of Virginia 24.2-955.3 provides the following:

- A violation of Article 2 of Chapter 9.5 of Title 24.2 shall be subject to (i) a civil penalty not to exceed \$1,000; or (ii) in the case of a violation occurring within the 14 days prior to or on the election day of the election to which the advertisement pertains, a civil penalty not to exceed \$2,500.
- A violation of Article 3 or 4 of Chapter 9.5 of Title 24.2 shall be subject to (i) a civil penalty not to exceed \$1,000 per occurrence; or (ii) in the case of a violation occurring within the 14 days prior to or on the election day of the election to which the advertisement pertains, a civil penalty not to exceed \$2,500 per occurrence. In no

event shall the total civil penalties imposed for multiple broadcasts of one particular campaign advertisement exceed \$10,000.

- A violation of Article 5 of Chapter 9.5 of Title 24.2 shall be subject to (i) a civil penalty not to exceed \$2,500.

Pursuant to §24.2-955.3, the State Board of Elections is notifying you via certified mail at least 10 days prior to the hearing. For more information, please visit the Department website:
<http://www.elections.virginia.gov/board>.

Sincerely,

Tammy L. Alexander

Corbo Repsonse

- Dear Ms. Alexander,
- Thank you once again for your detailed phone message and for speaking with me on Monday, July 29th in regard to the possible campaign ad violation. I wanted to again express my apology for the photos that were posted on FaceBook that appear to be a violation and thank you for the opportunity to address the concerns through email.
- Banner - Our parade banner has the paid for phrase at the bottom of the banner and the photo shows a curled bottom, therefore it is not seen clearly in the photo. I have attached two photos showing the disclosure statement. We have brought the concern to our vendor and they have agreed to restitched at the bottom allowing better visibility while it is displayed.
- T-Shirts - Our t-shirts in the FaceBook photo only show the front side and our disclaimer is on the back with the LEA approved logo. I have attached three photos and wanted to point out, although the photo looks like a sticker, it is actually an iron on decal.
- Thank you once again for bringing these issues to our attention and I hope this satisfies the concerns of the committee. Please let me know if you need additional information.
- Sincerely,
- Denise Corbo
- 703-517-3728

Corbo Response

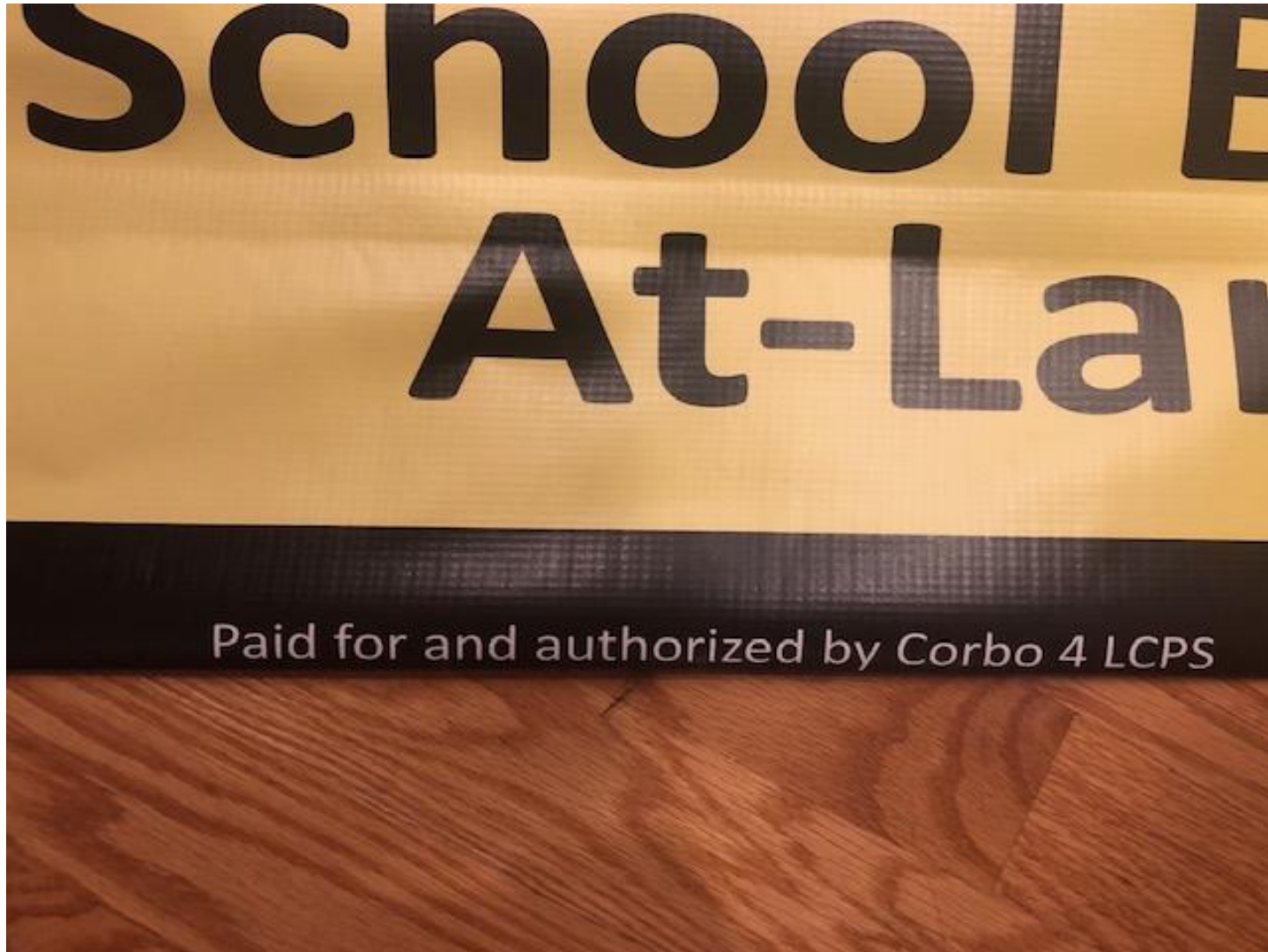

2. David F. Williams



Tell us WHERE and WHEN you saw the ad(s). Add additional pages if needed.
THE FOLLOWING PICTURES DEPICT THE LOCATIONS OF PRINT MEDIA THAT DOES NOT BEAR THE REQUIRED LEGEND OR INCLUDE THE STATEMENT PER CODE OF VIRGINIA 24.2-956.1 "PAID FOR BY (POLITICAL CAMPAIGN)". THESE PICTURES WERE TAKEN BETWEEN 6/22/2019 - 6/24/2019



COMMONWEALTH of VIRGINIA
DEPARTMENT OF ELECTIONS

Christopher E. "Chris" Piper
Commissioner

Jessica N. Bowman
Deputy Commissioner

July 23, 2019

David F. Williams
3011 Longdale Furnace Rd
Clifton Forge, Virginia 24422

Dear David F. Williams:

The State Board of Elections is in receipt of a complaint regarding a possible violation of Virginia's Stand by Your Ad law (Chapter 9.5 of Title 24.2 of the Code of Virginia) by David F. Williams. A copy of the challenged advertisement is included with this letter.

The State Board of Elections is holding a public meeting on Tuesday, August 6, 2019 at 1:00 P.M. to determine whether a violation has occurred and whether to impose civil penalties. You or a representative may attend and/or provide additional information to the Board that may be helpful in regarding this matter. You may also email a response to the complaint and/or information you would like the Board to consider to the Department of Elections Campaign Finance team at CFDA@elections.virginia.gov.

For more information about how the State Board of Elections adjudicates complaints regarding campaign advertisements, please refer to SBE Policy 2018-001, available online on the Department of Elections website: <https://www.elections.virginia.gov/media/formwarehouse/Board-Policies/SBE-Policy-2018-001-StandByYourAdHearings.pdf>.

The meeting will be held in Senate Room 3 in the Virginia State Capitol, located at 1000 Bank St, Richmond, Virginia, 23219. To get to Senate Room 3, please enter through the main entrance to the Capitol building on Bank Street.

The Code of Virginia 24.2-955.3 provides the following:

- A violation of Article 2 of Chapter 9.5 of Title 24.2 shall be subject to (i) a civil penalty not to exceed \$1,000; or (ii) in the case of a violation occurring within the 14 days prior to or on the election day of the election to which the advertisement pertains, a civil penalty not to exceed \$2,500.
- A violation of Article 3 or 4 of Chapter 9.5 of Title 24.2 shall be subject to (i) a civil penalty not to exceed \$1,000 per occurrence; or (ii) in the case of a violation occurring within the 14 days prior to or on the election day of the election to which the advertisement pertains, a civil penalty not to exceed \$2,500 per occurrence. In no event shall the total civil penalties imposed for multiple broadcasts of one particular campaign advertisement exceed \$10,000.

- A violation of Article 5 of Chapter 9.5 of Title 24.2 shall be subject to (i) a civil penalty not to exceed \$2,500.

Pursuant to §24.2-955.3, the State Board of Elections is notifying you via certified mail at least 10 days prior to the hearing. For more information, please visit the Department website: <http://www.elections.virginia.gov/board>.

Sincerely,

Tammy L. Alexander

David F. Williams (cont.)



Response from David F. Willaims

Ms. Alexander,

Per our phone conversation, I am sending you this e-mail about the complaint you received about my signs. The campaign signs went out over a month ago and did not have "paid for by candidate" on them. There was only 25 signs out during this time. One week after the signs went out, I discovered the oversight and I went around and hand wrote on the signs to reflect "paid for by candidate". I contacted Tiny Rose the voter register in Alleghany County and advised her of the problem and correction shortly afterwards. I apologize to you and the board for my mistake but it was taken care of several weeks ago. As we discussed on the phone, my opponent knows this but still made the complaint. Again, I am sorry for my mistake.

Sincerely,

David Williams

Williams Response from Candidate's GR

- Tammy,
- It was brought to my attention several weeks ago by the candidate himself, David F. Williams, that someone had called him and told him that Kevin Hall was in their yard taking pictures of Mr. Williams sign because it did not have the “Paid for by the Candidate” printed on it. Before coming into my office to report it himself Mr. Williams had already corrected all of his signs. No one else ever reported it to me other than Mr. Williams.
- I was told in the past when someone came into my office complaining about signs that that is not our issue to handle since it is outside of our office. That it is between the candidate and the person with the complaint and The Department of Elections/ELECT.
- Have a nice day,
- Tiney K. Rose-VREO

3. Donald Smith for Sheriff CC-15-00114

Augusta County Sheriff's Office - Sheriff Donald L. Smith

It has been an honor to serve Augusta County as your Sheriff. I will seek re-election this year and would greatly appreciate your support. Please come to my official announcement Wednesday, March 27, as I kick off my 2019 campaign for Sheriff. I look forward to seeing each one of you.

DONALD SMITH FOR SHERIFF
THE PEOPLE'S SHERIFF

You are Cordially Invited to

THE OFFICIAL ANNOUNCEMENT FOR
DONALD L. SMITH
AS I ASK FOR YOUR SUPPORT TO SEEK
RE-ELECTION FOR SHERIFF

MARCH 27, 2019 - 6:00 PM
VERONA FIRE HOUSE
304 LEE HIGHWAY, VERONA

Light refreshments will be served. We hope to see you there!

540 reactions, 60 Comments, 140 Shares

Tell us WHERE and WHEN you saw the ad(s). Add additional pages if needed.
March 20, 2019 to present. See attached screen shot of the Augusta County Sheriff's Office - Sheriff Donald L. Smith Facebook page from March 20, 2019. This post is still present and active. Donald Smith for Sheriff's Campaign Manager, Michelle Smith Fix is listed as a Team Member of the official Augusta County Sheriff's Office- Sheriff Donald L. Smith Facebook Account, however county records do not indicate that she is a employee of the Department or of the county. The same add was posted on Smith's official political Facebook Account on March 15th which has posted "Paid for by Donald Smith for Sheriff" however on the Official Government Facebook Account there is nothing that stated anywhere "paid for or authorized". Reason for doing this was to increase exposure to event. When compared he received over a 395% increase in likes and over 6000% in comments.



COMMONWEALTH of VIRGINIA
DEPARTMENT OF ELECTIONS

Christopher E. "Chris" Piper
Commissioner

Jessica N. Bowman
Deputy Commissioner

July 23, 2019

Donald Smith for Sheriff CC-15-00114
P. O. Box 811
Verona, Virginia 24482

Dear Donald Smith for Sheriff:

The State Board of Elections is in receipt of a complaint regarding a possible violation of Virginia's Stand by Your Ad law (Chapter 9.5 of Title 24.2 of the Code of Virginia) by Donald Smith for Sheriff CC-15-00114. A copy of the challenged advertisement is included with this letter.

The State Board of Elections is holding a public meeting on Tuesday, August 6, 2019 at 1:00 P.M. to determine whether a violation has occurred and whether to impose civil penalties. You or a representative may attend and/or provide additional information to the Board that may be helpful in regarding this matter. You may also email a response to the complaint and/or information you would like the Board to consider to the Department of Elections Campaign Finance team at CFDA@elections.virginia.gov.

For more information about how the State Board of Elections adjudicates complaints regarding campaign advertisements, please refer to SBE Policy 2018-001, available online on the Department of Elections website:
<https://www.elections.virginia.gov/media/formswarehouse/Board-Policies/SBE-Policy-2018-001-StandByYourAdHearings.pdf>

The meeting will be held in Senate Room 3 in the Virginia State Capitol, located at 1000 Bank St, Richmond, Virginia, 23219. To get to Senate Room 3, please enter through the main entrance to the Capitol building on Bank Street.

The Code of Virginia 24.2-955.3 provides the following:

- A violation of Article 2 of Chapter 9.5 of Title 24.2 shall be subject to (i) a civil penalty not to exceed \$1,000; or (ii) in the case of a violation occurring within the 14 days prior to or on the election day of the election to which the advertisement pertains, a civil penalty not to exceed \$2,500.
- A violation of Article 3 or 4 of Chapter 9.5 of Title 24.2 shall be subject to (i) a civil penalty not to exceed \$1,000 per occurrence; or (ii) in the case of a violation occurring within the 14 days prior to or on the election day of the election to which the advertisement pertains, a civil penalty not to exceed \$2,500 per occurrence. In no

event shall the total civil penalties imposed for multiple broadcasts of one particular campaign advertisement exceed \$10,000.

- A violation of Article 5 of Chapter 9.5 of Title 24.2 shall be subject to (i) a civil penalty not to exceed \$2,500.

Pursuant to §24.2-955.3, the State Board of Elections is notifying you via certified mail at least 10 days prior to the hearing. For more information, please visit the Department website:
<http://www.elections.virginia.gov/board>.

Sincerely,

Tammy L. Alexander

campaign for Sheriff. I look forward to seeing each one of you.

Augusta County
Sheriff's Office -
Sheriff Donald L.
Smith

@augustacountysheriffsof
fice

Home

About

Reviews

Photos

Videos

Events

Posts

Community

Create a Page



540

60 Comments 140 Shares



Augusta County Sheriff's Office
Donald L. Smith, Sheriff

127 Lee Highway
 P.O. Box 860
 Verona, Virginia 24482

Phone (540)245-5333
 Fax (540)245-5330
 Website: www.co.augusta.va.us

July 26, 2019

To: Tammy L. Alexander and Board Members
 From: Sheriff Donald L. Smith
 Reference: Stand by Your Ad Law Chapter 9.5 of Title 24.2

I am writing to address the complaint you had on my Donald Smith for Sheriff Campaign. The ad posted on March 20, 2019 to the Augusta County Sheriff's Office Facebook page announced my intention to run for a second term. I placed the invite on both the Sheriff's office and campaign Facebook pages and sent it to the media as the sheriff notifying Augusta County citizens that I would seek re-election. I was merely inviting the community to let them know that I was seeking re-election for the Office of the Sheriff. In no way, was I attempting to violate the listed code section or offend any opponent running against me.

This post was advertised on both pages because I am the sitting sheriff and I was announcing my intentions to run. In an effort to address this complaint, I have revised this post on my Sheriff's Office Facebook page and my Campaign Facebook Page to reflect "Authorized and Paid for by Donald Smith for Sheriff." Although all of my campaign page posts are linked to my campaign Facebook page and at the top clearly displays: "Paid for by Donald Smith for Sheriff", I have gone back to every post on my campaign page and posted "Authorized by Donald Smith for Sheriff" and will continue to do so on every post even though 14.3 of the Department of Elections summary of laws and policies states that I have it covered because of the link. I know this is more than

Smith Response



Augusta County Sheriff's Office
Donald L. Smith, Sheriff

127 Lee Highway
 P.O. Box 860
 Verona, Virginia 24482

Phone (540)245-5333
 Fax (540)245-5330
 Website: www.co.augusta.va.us

necessary, but I in no way want to violate any laws or policies again and want everyone to know that I have indeed authorized these posts.

Regarding the claim that the "Sheriff is known to use his power and position to get back at people that go against him," this is a political tactic the other candidate has fabricated. The accusations made are not true. I have attached a cease and desist order that was faxed to my office on July 1, 2019, by Kester for Sheriff that claims the same. I am a Sheriff for the people and work tirelessly to keep the citizens of Augusta County safe and am very involved in our community.

Please accept this letter as an apology and correspondence that these issues have been corrected. If any of you have questions please feel free to contact me directly.

Respectfully submitted.

4. Dwayne T. Wade CC-19-00772

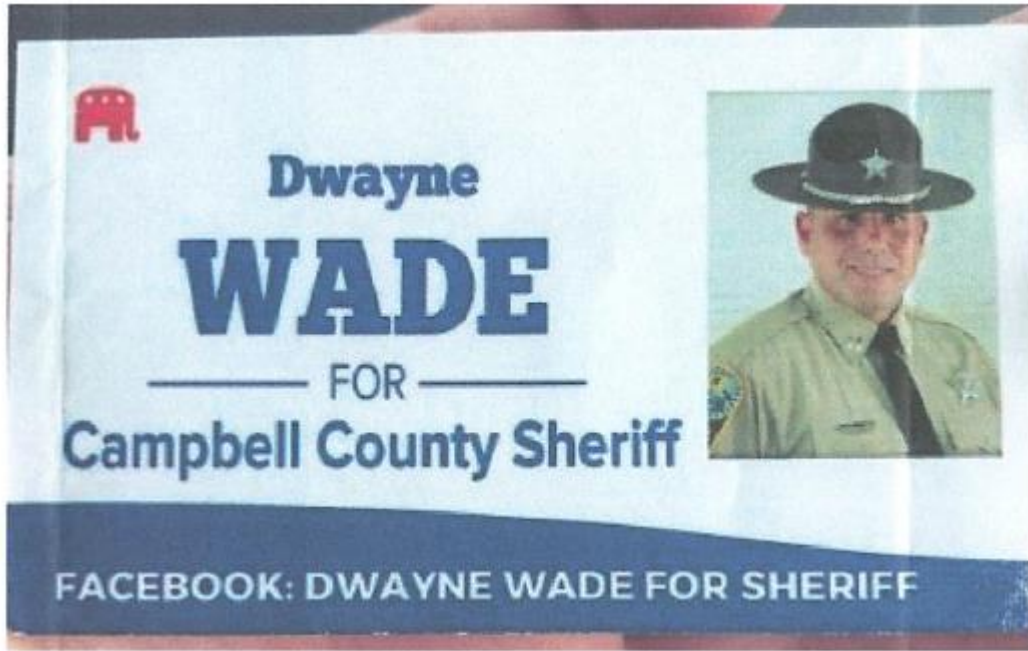

3. Tell us WHERE and WHEN you saw the ad(s). *Add additional pages if needed.*

El Cabrito's Resturant - 21004 Timberlake Road, Lynchburg, VA 24502 - June 2, 2019 - 3 cards (1 hard copy/2 photo)

El Cabrito's Resturant - 21004 Timberlake Road, Lynchburg, VA 24502 - June 12, 2019 (1 photo)

El Cabrito's Restaurant - 21004 Timberlake Road, Lynchburg, VA 24502 - May 20, 2019 (1 photo)

Burger's Shakes & Cream - 104 Lusardi Drive, Brookneal, VA 24528 - June 13, 2019 (1 photo)

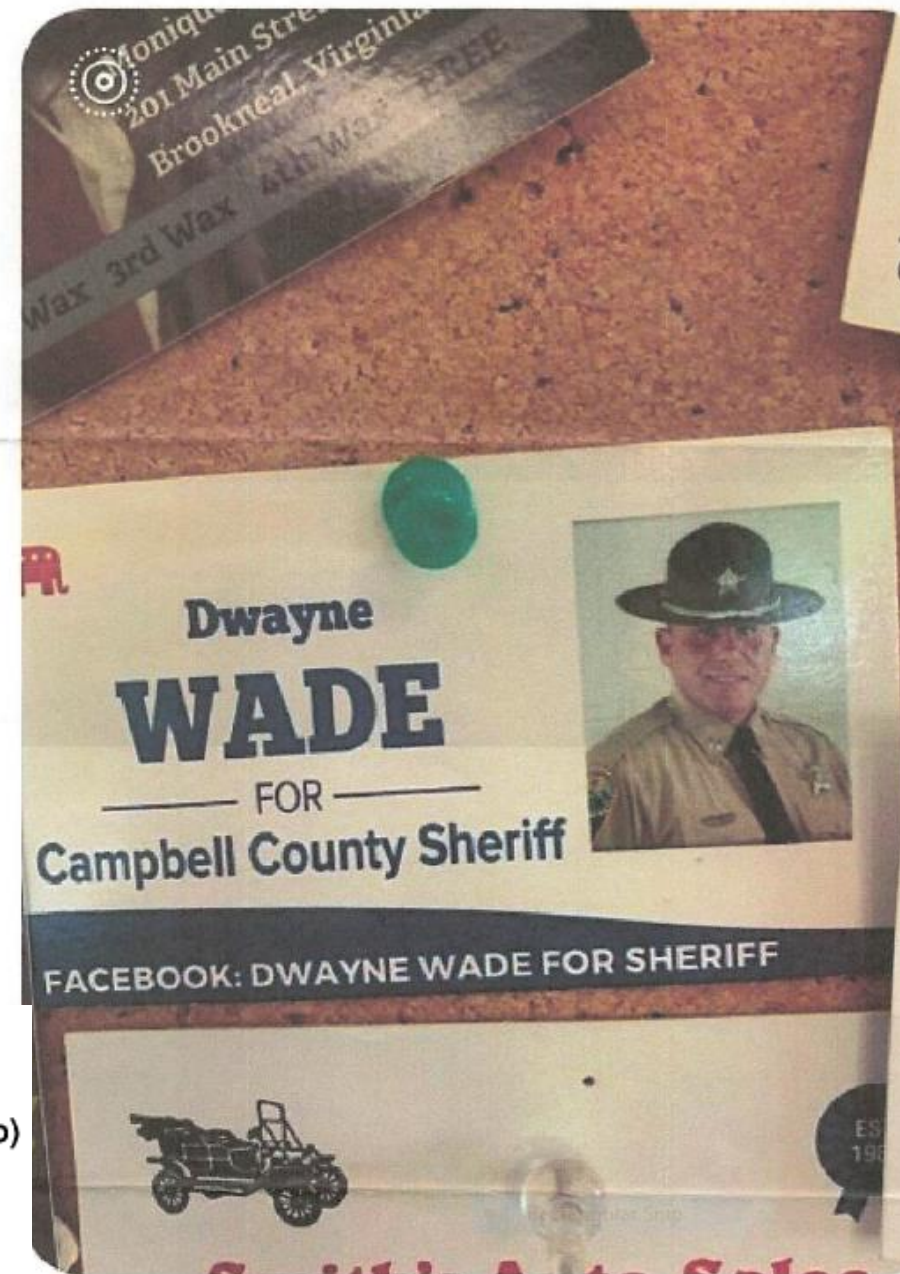

Burgers shakes and cream



COMMONWEALTH of VIRGINIA
DEPARTMENT OF ELECTIONS

Christopher E. "Chris" Piper
Commissioner

Jessica N. Bowman
Deputy Commissioner

July 23, 2019

Dwayne T. Wade CC-19-00772
160 Pine Dr
Lynchburg, Virginia 24502

Dear Dwayne T. Wade:

The State Board of Elections is in receipt of a complaint regarding a possible violation of Virginia's Stand by Your Ad law (Chapter 9.5 of Title 24.2 of the Code of Virginia) by Dwayne T. Wade CC-19-00772. A copy of the challenged advertisement is included with this letter.

The State Board of Elections is holding a public meeting on Tuesday, August 6, 2019 at 1:00 P.M. to determine whether a violation has occurred and whether to impose civil penalties. You or a representative may attend and/or provide additional information to the Board that may be helpful in regarding this matter. You may also email a response to the complaint and/or information you would like the Board to consider to the Department of Elections Campaign Finance team at CFDA@elections.virginia.gov.

For more information about how the State Board of Elections adjudicates complaints regarding campaign advertisements, please refer to SBE Policy 2018-001, available online on the Department of Elections website:
<https://www.elections.virginia.gov/media/formwarehouse/Board-Policies/SBE-Policy-2018-001-StandByYourAdHearings.pdf>.

The meeting will be held in Senate Room 3 in the Virginia State Capitol, located at 1000 Bank St, Richmond, Virginia, 23219. To get to Senate Room 3, please enter through the main entrance to the Capitol building on Bank Street.

The Code of Virginia 24.2-955.3 provides the following:

- A violation of Article 2 of Chapter 9.5 of Title 24.2 shall be subject to (i) a civil penalty not to exceed \$1,000; or (ii) in the case of a violation occurring within the 14 days prior to or on the election day of the election to which the advertisement pertains, a civil penalty not to exceed \$2,500.
- A violation of Article 3 or 4 of Chapter 9.5 of Title 24.2 shall be subject to (i) a civil penalty not to exceed \$1,000 per occurrence; or (ii) in the case of a violation occurring within the 14 days prior to or on the election day of the election to which the advertisement pertains, a civil penalty not to exceed \$2,500 per occurrence. In no event shall the total civil penalties imposed for multiple broadcasts of one particular campaign advertisement exceed \$10,000.

- A violation of Article 5 of Chapter 9.5 of Title 24.2 shall be subject to (i) a civil penalty not to exceed \$2,500.

Pursuant to §24.2-955.3, the State Board of Elections is notifying you via certified mail at least 10 days prior to the hearing. For more information, please visit the Department website: <http://www.elections.virginia.gov/board>.

Sincerely,

Tammy L. Alexander

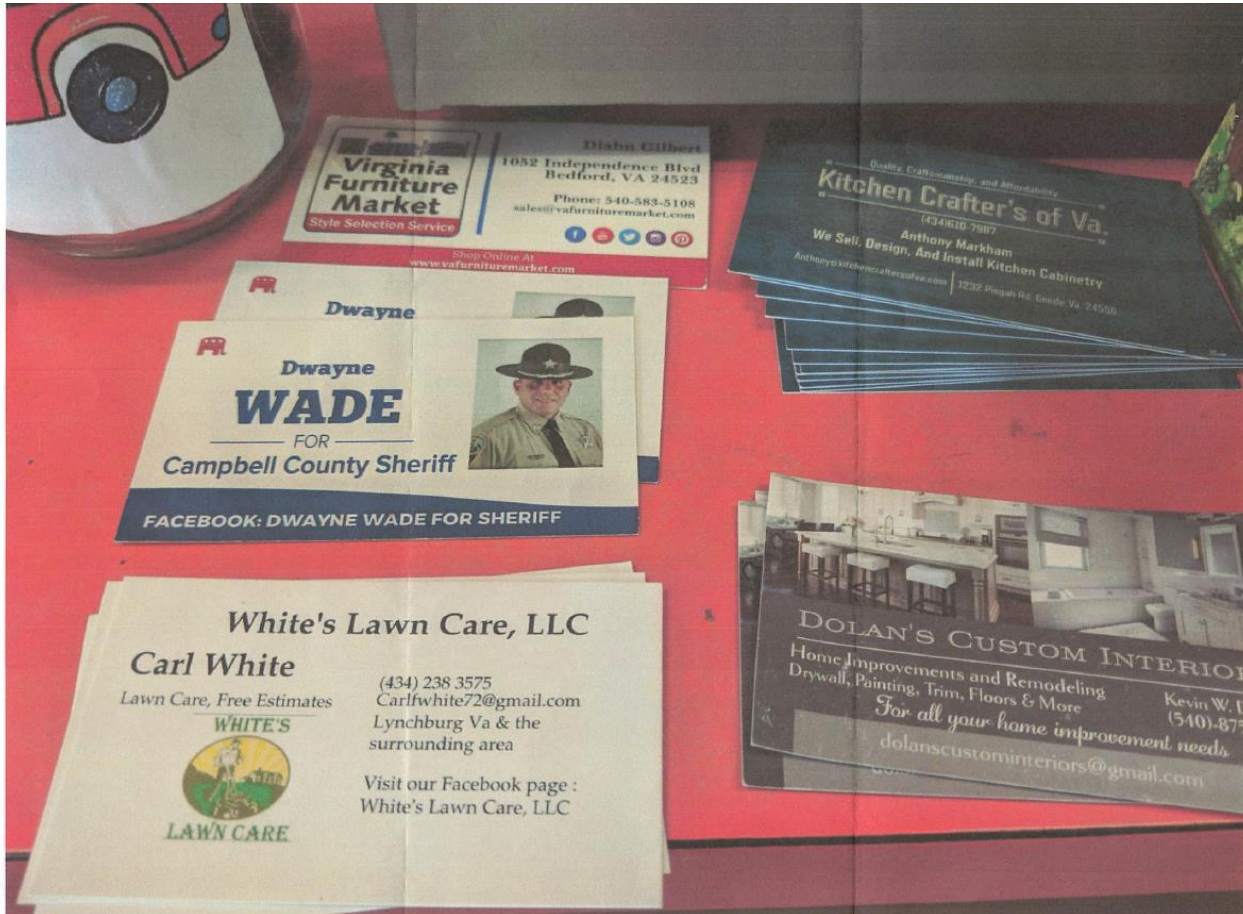

El caburritos Timberlake Road. James Monahan business

Wade Response

July 25, 2019

Dwayne T. Wade
160 Pine Drive
Lynchburg VA 24502

To: State Board of Elections – Commonwealth of Virginia

RE: Complaint against Dwayne Wade CC-19-00772. Letter dated July 19, 2019

Dear Board Members,

This letter is to serve as my response and explanation to the Board of Elections regarding my possible violation of Virginia's Stand by Your Ad law (Chapter 9.5 of Title 24.2 of the Code of Virginia).

As can clearly be seen on your enclosures the words "Paid for and authorized by Dwayne Wade for Sheriff" do not appear on these business cards, and for this we take full responsibility and apologize to the Board of Elections and any citizens who may have been confused by this omission.

It was never the intention of myself or the campaign to mislead anyone regarding the origination or ownership of these cards but a misunderstanding of the law on the part of the volunteer who had these printed, and an oversight on the part of the campaign in allowing some to be taken and disseminated by volunteers prior to the realization that the proper wording to fulfill legal requirements had been omitted.

We had attempted to have them returned to us, and did not realize that there were any posted in public places. We have checked with all our volunteers and directed them to please remove any they have posted and destroy any they may still have. These cards were ordered very early in the campaign while we were still organizing and being a first time candidate this mistake was made and not caught soon enough.

Again, I apologize to the board and the citizens for this error of omission and can assure the Board that all of our current campaign materials have the proper disclaimer printed on them that meets the requirements of the "Stand by Your Ad" law as will any future advertisements or campaign materials.

If further information is required from me or my campaign please do not hesitate to contact me and I will be as helpful as I can.

Sincerely,

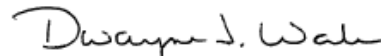

Dwayne T. Wade

5. Galvin for Delegate CC-19-00330

Sample Ballot

Commonwealth of Virginia
City of Charlottesville
Democratic Party Primary Election
Tuesday, June 11, 2019

Please use a blue or black ink pen to
mark inside the box next to your choice.

Member
House of Delegates
57th District

Vote for only one

Sally L. Hudson

Kathleen M. Galvin

Member **You Can**
City Council **Choose Up To 3**

Vote for not more than three

Michael K. Payne

R. F. "Bob" Fenwick, Jr.

Brian R. Pinkston

Sena A. Magill

J. Lloyd Snook, III

Paid for and Authorized by Galvin for Delegate



COMMONWEALTH of VIRGINIA
DEPARTMENT OF ELECTIONS

Christopher E. "Chris" Piper
Commissioner

Jessica N. Bowman
Deputy Commissioner

July 23, 2019

Galvin for Delegate CC-19-00330
712 Lyons Avenue
Charlottesville, Virginia 22902

Dear Galvin for Delegate:

The State Board of Elections is in receipt of a complaint regarding a possible violation of Virginia's Stand by Your Ad law (Chapter 9.5 of Title 24.2 of the Code of Virginia) by Galvin for Delegate CC-19-00330. A copy of the challenged advertisement is included with this letter.

The State Board of Elections is holding a public meeting on Tuesday, August 6, 2019 at 1:00 P.M. to determine whether a violation has occurred and whether to impose civil penalties. You or a representative may attend and/or provide additional information to the Board that may be helpful in regarding this matter. You may also email a response to the complaint and/or information you would like the Board to consider to the Department of Elections Campaign Finance team at CFDA@elections.virginia.gov.

For more information about how the State Board of Elections adjudicates complaints regarding campaign advertisements, please refer to SBE Policy 2018-001, available online on the Department of Elections website:
<https://www.elections.virginia.gov/media/formswarehouse/Board-Policies/SBE-Policy-2018-001-StandByYourAdHearings.pdf>.

The meeting will be held in Senate Room 3 in the Virginia State Capitol, located at 1000 Bank St, Richmond, Virginia, 23219. To get to Senate Room 3, please enter through the main entrance to the Capitol building on Bank Street.

The Code of Virginia 24.2-955.3 provides the following:

- A violation of Article 2 of Chapter 9.5 of Title 24.2 shall be subject to (i) a civil penalty not to exceed \$1,000; or (ii) in the case of a violation occurring within the 14 days prior to or on the election day of the election to which the advertisement pertains, a civil penalty not to exceed \$2,500.
- A violation of Article 3 or 4 of Chapter 9.5 of Title 24.2 shall be subject to (i) a civil penalty not to exceed \$1,000 per occurrence; or (ii) in the case of a violation occurring within the 14 days prior to or on the election day of the election to which the advertisement pertains, a civil penalty not to exceed \$2,500 per occurrence. In no event shall the total civil penalties imposed for multiple broadcasts of one particular campaign advertisement exceed \$10,000.

- A violation of Article 5 of Chapter 9.5 of Title 24.2 shall be subject to (i) a civil penalty not to exceed \$2,500.

Pursuant to §24.2-955.3, the State Board of Elections is notifying you via certified mail at least 10 days prior to the hearing. For more information, please visit the Department website: <http://www.elections.virginia.gov/board>.

Sincerely,

Tammy L. Alexander

Galvin Response

The Galvin for Delegate campaign is responsible for the paper version of the sample ballot. However, the Galvin for Delegate campaign is **not** responsible for the image of this sample ballot which was disseminated via Twitter. Attached to this correspondence, you will find a screenshot that clearly shows that the image Ms. Bencoach sent to the Department of Elections was posted by the Twitter account for the Charlottesville Democratic Socialists of America (DSA) on June 11, 2019, not the Galvin for Delegate campaign. As the text in the tweet probably makes clear, this post was not made at the request of the Galvin for Delegate campaign, it was not authorized by the Galvin for Delegate campaign, and it was not done in coordination with the Galvin for Delegate campaign. Neither I nor my committee were connected in any way with the creation or dissemination of the photo on Twitter, and therefore I believe it would be unfair to find that Galvin for Delegate violated the “Stand By Your Ad” provision of Title 24.2-956 because another entity posted a photo of our sample ballot on a social media platform.

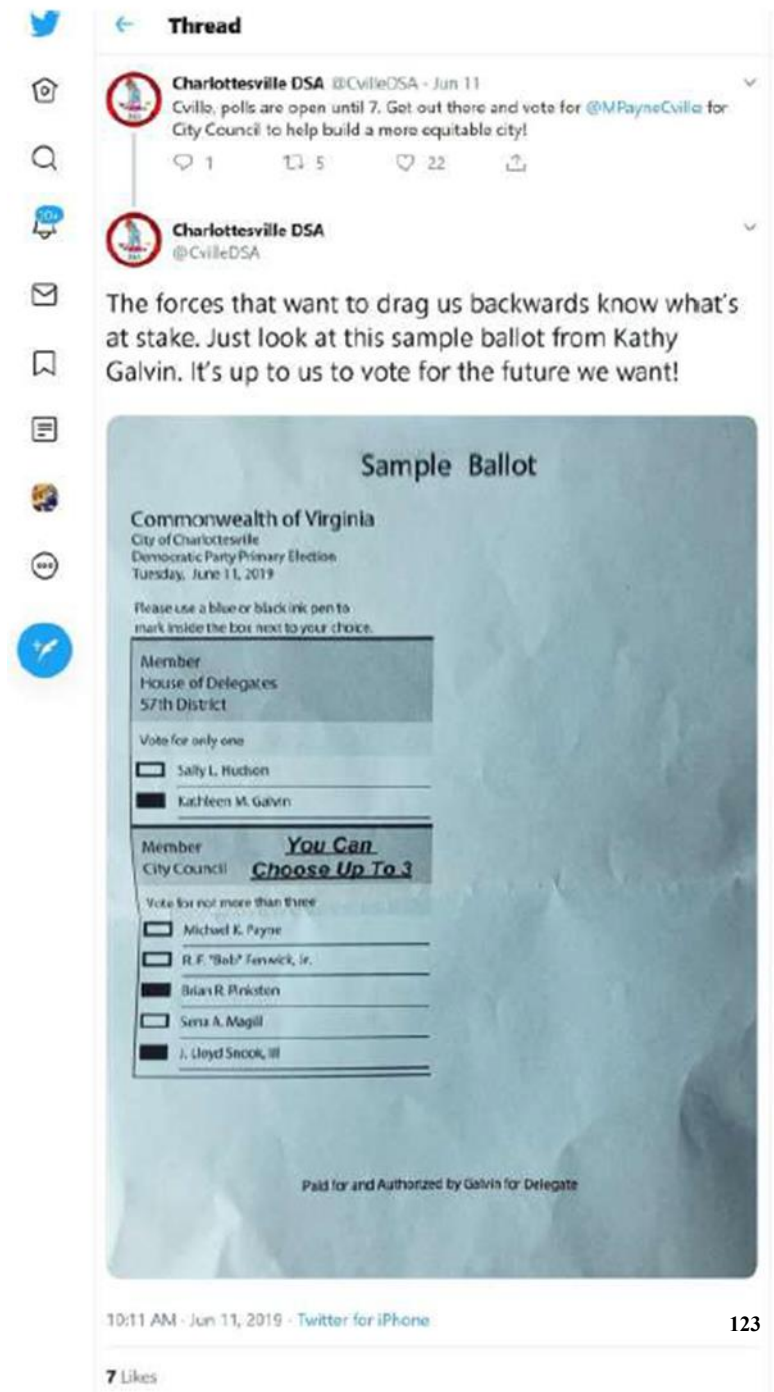

Galvin for Delegate did create the paper sample ballot and used it on June 11, 2019, for the Democratic primary election. I was not aware at the time that the disclaimer was insufficient for this printed material, and so the absence of language addressing whether any of the other candidates for office whose names appeared on the sample ballot had (or had not) authorized it was not intentional. The incomplete disclosure was an oversight due to lack of knowledge. I know that this does not excuse any failure to comply in full with the disclosure requirements for print media sponsored by campaign committees in Title 24.2-956, but I hope the Board will take this into consideration when determining whether to assess a civil penalty or what the amount of any such penalty should be.

I look forward to discussing this further with the Board on Tuesday, at 1 pm, in Senate Room 3 in the Virginia State Capitol. I thank you for your consideration.

Sincerely,

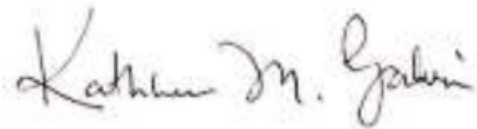
A handwritten signature in cursive script that reads "Kathleen M. Galvin".

Kathleen M. Galvin
Kathleen M. Galvin, Architect AIA
712 Lyons Avenue
Charlottesville, VA 22902

cc: Christopher Piper
Jessica Bowman
Senator Creigh Deeds
Delegate David Toscano

Tracking History



Reminder to Schedule Redelivery of your item before August 6, 2019

This is a reminder to arrange for redelivery of your item before August 6, 2019 or your item will be returned on August 7, 2019. You may arrange redelivery by using the Schedule a Redelivery feature on this page or may pick up the item at the Post Office indicated on the notice.

July 23, 2019, 5:15 pm

Notice Left (No Authorized Recipient Available)
CHARLOTTESVILLE, VA 22902

July 23, 2019

In Transit to Next Facility

July 21, 2019, 1:30 am

Departed USPS Regional Facility
RICHMOND VA DISTRIBUTION CENTER

July 19, 2019, 8:42 pm

Arrived at USPS Regional Facility
RICHMOND VA DISTRIBUTION CENTER

July 19, 2019, 5:07 pm

Departed Post Office
RICHMOND, VA 23219

July 19, 2019, 4:53 pm

USPS in possession of item
RICHMOND, VA 23219

6. Gwen for Office CC-19-00683



Today (Thursday, July 11, 2019) Gwen Bell placed signs at the 7/11 located at 910 Garrisonville Rd, Stafford, VA 22556. The signs did not list any disclaimer.



COMMONWEALTH of VIRGINIA

DEPARTMENT OF ELECTIONS

Christopher E. "Chris" Piper
Commissioner

Jessica N. Bowman
Deputy Commissioner

July 23, 2019

Gwen for Office CC-19-00683
17 Sweet William Drive
Stafford, Virginia 22554

Dear Gwen for Office:

The State Board of Elections is in receipt of a complaint regarding a possible violation of Virginia's Stand by Your Ad law (Chapter 9.5 of Title 24.2 of the Code of Virginia) by Gwen for Office CC-19-00683. A copy of the challenged advertisement is included with this letter.

The State Board of Elections is holding a public meeting on Tuesday, August 6, 2019 at 1:00 P.M. to determine whether a violation has occurred and whether to impose civil penalties. You or a representative may attend and/or provide additional information to the Board that may be helpful in regarding this matter. You may also email a response to the complaint and/or information you would like the Board to consider to the Department of Elections Campaign Finance team at CFDA@elections.virginia.gov.

For more information about how the State Board of Elections adjudicates complaints regarding campaign advertisements, please refer to SBE Policy 2018-001, available online on the Department of Elections website:
<https://www.elections.virginia.gov/media/formwarehouse/Board-Policies/SBE-Policy-2018-001-StandByYourAdHearings.pdf>.

The meeting will be held in Senate Room 3 in the Virginia State Capitol, located at 1000 Bank St, Richmond, Virginia, 23219. To get to Senate Room 3, please enter through the main entrance to the Capitol building on Bank Street.

The Code of Virginia 24.2-955.3 provides the following:

- A violation of Article 2 of Chapter 9.5 of Title 24.2 shall be subject to (i) a civil penalty not to exceed \$1,000; or (ii) in the case of a violation occurring within the 14 days prior to or on the election day of the election to which the advertisement pertains, a civil penalty not to exceed \$2,500.
- A violation of Article 3 or 4 of Chapter 9.5 of Title 24.2 shall be subject to (i) a civil penalty not to exceed \$1,000 per occurrence; or (ii) in the case of a violation occurring within the 14 days prior to or on the election day of the election to which the advertisement pertains, a civil penalty not to exceed \$2,500 per occurrence. In no event shall the total civil penalties imposed for multiple broadcasts of one particular campaign advertisement exceed \$10,000.

- A violation of Article 5 of Chapter 9.5 of Title 24.2 shall be subject to (i) a civil penalty not to exceed \$2,500.

Pursuant to §24.2-955.3, the State Board of Elections is notifying you via certified mail at least 10 days prior to the hearing. For more information, please visit the Department website: <http://www.elections.virginia.gov/board>.

Sincerely,

Tammy L. Alexander

7. Elect Kenya Savage – At Large Candidate CC-19-00294

----- Forwarded message -----

From: Creal French <crealfrench@gmail.com>
Date: Wed, May 29, 2019 at 8:14 PM
Subject: Political Campaign Disclosure Requirement - Notice of Violation
To: <info@elections.virginia.gov>
Cc: Brown, Judy <Judy.Brown@loudoun.gov>

State Board of Elections
Department of Elections
1100 Bank St Fl 1
Richmond, VA 23219

VIA E-mail at info@elections.virginia.gov

To the State Board of Elections:

I write to bring your attention to a violation of the disclosure requirements of Chapter 9.5 of Title 24.2 of the Code of Virginia by **Kenya A. Savage**, candidate for Loudoun County School Board (At-Large).

Ms. Savage's campaign has produced a website (electkenyasavage.com) that lacks the visual legend or statement required by section 24.2-956.

I request that you take appropriate enforcement action.

Sincerely,

Creal S. French

cc: Judy Brown, General Registrar, Loudoun County

----- Kenya Savage - At Large Candidate -----
42020 Village Center Plaza, Suite 120, PMB 230, Stone Ridge, VA 20105, USA

Paid for and Authorized by Friends of Kenya A. Savage

Power



COMMONWEALTH of VIRGINIA

DEPARTMENT OF ELECTIONS

Christopher E. "Chris" Piper
Commissioner

Jessica N. Bowman
Deputy Commissioner

July 23, 2019

Kenya Savage CC-19-00294
25886 Rawley Springs Dr
Chantilly, Virginia 20152

Dear Kenya Savage:

The State Board of Elections is in receipt of a complaint regarding a possible violation of Virginia's Stand by Your Ad law (Chapter 9.5 of Title 24.2 of the Code of Virginia) by Kenya Savage CC-19-00294. A copy of the challenged advertisement is included with this letter.

The State Board of Elections is holding a public meeting on Tuesday, August 6, 2019 at 1:00 P.M. to determine whether a violation has occurred and whether to impose civil penalties. You or a representative may attend and/or provide additional information to the Board that may be helpful in regarding this matter. You may also email a response to the complaint and/or information you would like the Board to consider to the Department of Elections Campaign Finance team at CFDA@elections.virginia.gov.

For more information about how the State Board of Elections adjudicates complaints regarding campaign advertisements, please refer to SBE Policy 2018-001, available online on the Department of Elections website:
<https://www.elections.virginia.gov/media/formwarehouse/Board-Policies/SBE-Policy-2018-001-StandByYourAdHearings.pdf>.

The meeting will be held in Senate Room 3 in the Virginia State Capitol, located at 1000 Bank St, Richmond, Virginia, 23219. To get to Senate Room 3, please enter through the main entrance to the Capitol building on Bank Street.

The Code of Virginia 24.2-955.3 provides the following:

- A violation of Article 2 of Chapter 9.5 of Title 24.2 shall be subject to (i) a civil penalty not to exceed \$1,000; or (ii) in the case of a violation occurring within the 14 days prior to or on the election day of the election to which the advertisement pertains, a civil penalty not to exceed \$2,500.
- A violation of Article 3 or 4 of Chapter 9.5 of Title 24.2 shall be subject to (i) a civil penalty not to exceed \$1,000 per occurrence; or (ii) in the case of a violation occurring within the 14 days prior to or on the election day of the election to which the advertisement pertains, a civil penalty not to exceed \$2,500 per occurrence. In no event shall the total civil penalties imposed for multiple broadcasts of one particular campaign advertisement exceed \$10,000.

- A violation of Article 5 of Chapter 9.5 of Title 24.2 shall be subject to (i) a civil penalty not to exceed \$2,500.

Pursuant to §24.2-955.3, the State Board of Elections is notifying you via certified mail at least 10 days prior to the hearing. For more information, please visit the Department website:
<http://www.elections.virginia.gov/board>.

Sincerely,

Tammy L. Alexander

Kenya Savage Response

Notice to Appear Notice- Savage, Loudoun County

3 messages

Kenya Savage <info@electkenyasavage.com>
To: "Tammy.alexander@elections.virginia.gov" <Tammy.alexander@elections.virginia.gov>
Cc: "tpauldaie@gmail.com" <tpauldaie@gmail.com>, "msspinks@hotmail.com" <msspinks@hotmail.com>

Good evening Tammy,

Thank you for your call this afternoon regarding my website and the certified letter that was sent to my home from the Commonwealth's of Virginia office.

Per our conversation this afternoon regarding not having a disclosure statement on my website, I have added the statement, *Paid for and Authorized by Kenya Savage*, and that text is now visible on my website.

Here is the link to my website, www.electkenyasavage.com. In addition, I have captured below a screen shot of the text and the orientation on all my webpages.

As you mentioned, it is not necessary for me to attend the meeting scheduled on Tuesday, August 6, 2019 @ 1300. Your guidance of updating the website and informing you that the updates were made satisfied my need to appear in person.

Please advise here if receipt of this email and that the below now satisfactorily addresses and resolves this concern and that no further actions are needed on my part.

As I endeavor to continue to serve my community, please advise if there is anything further.

v/r,
Kenya Savage
Candidate, Loudoun County School Board, At-Large Representative
Email: info@electkenyasavage.com
Website: www.electkenyasavage.com



November 5, 2019

www.electkenyasavage.com

Trusted, solid, and familiar leader for education for all students across Loudoun County.

Elect Kenya Savage - At Large Candidate

42020 Village Center Plaza, Suite 120, PMB 230, Stone Ridge, VA 20105, USA



8. Friends of Levin White 2019 CC-18-00282

This complaint is being filed against the Friends of Levin White 2019 campaign committee.

This event advertised Levin White's candidacy, as seen at the bottom of the posting on Facebook. As seen, there is no disclaimer

on this advertisement, but there is clearly a weblink to his sheriff campaign website. Please note, Levin White is using both "Levin White for Sheriff" and "A Safer Goochland" facebook pages to forward his candidacy.

< A Safer Goochland's Post ...

 A Safer Goochland updated the event cover photo in **Minimize Your Chances of Becoming a Victim of Violent Crime.** 
Yesterday at 9:46 PM · 

Minimize Your Chances of Becoming A Victim of Violent Crime

Join us at:

Jerusalem Baptist Church

994 Three Chopt Rd.
Manakin Sabot, VA 23103

6:00pm - 7:00pm

Facilitated By:
Levin White
Law Enforcement Professional
28 Years of Major/Violent Crime Experience

LevinWhiteforSheriff.com

131



COMMONWEALTH of VIRGINIA
DEPARTMENT OF ELECTIONS

Christopher E. "Chris" Piper
Commissioner

Jessica N. Bowman
Deputy Commissioner

July 23, 2019

Friends of Levin White 2019 CC-18-00282
1445 River Road West
Crozier, Virginia 23039

Dear Friends of Levin White 2019:

The State Board of Elections is in receipt of a complaint regarding a possible violation of Virginia's Stand by Your Ad law (Chapter 9.5 of Title 24.2 of the Code of Virginia) by Friends of Levin White 2019 CC-18-00282. A copy of the challenged advertisement is included with this letter.

The State Board of Elections is holding a public meeting on Tuesday, August 6, 2019 at 1:00 P.M. to determine whether a violation has occurred and whether to impose civil penalties. You or a representative may attend and/or provide additional information to the Board that may be helpful in regarding this matter. You may also email a response to the complaint and/or information you would like the Board to consider to the Department of Elections Campaign Finance team at CFDA@elections.virginia.gov.

For more information about how the State Board of Elections adjudicates complaints regarding campaign advertisements, please refer to SBE Policy 2018-001, available online on the Department of Elections website:
<https://www.elections.virginia.gov/media/formswarehouse/Board-Policies/SBE-Policy-2018-001-StandByYourAdHearings.pdf>

The meeting will be held in Senate Room 3 in the Virginia State Capitol, located at 1000 Bank St, Richmond, Virginia, 23219. To get to Senate Room 3, please enter through the main entrance to the Capitol building on Bank Street.

The Code of Virginia 24.2-955.3 provides the following:

- A violation of Article 2 of Chapter 9.5 of Title 24.2 shall be subject to (i) a civil penalty not to exceed \$1,000; or (ii) in the case of a violation occurring within the 14 days prior to or on the election day of the election to which the advertisement pertains, a civil penalty not to exceed \$2,500.
- A violation of Article 3 or 4 of Chapter 9.5 of Title 24.2 shall be subject to (i) a civil penalty not to exceed \$1,000 per occurrence; or (ii) in the case of a violation occurring within the 14 days prior to or on the election day of the election to which the advertisement pertains, a civil penalty not to exceed \$2,500 per occurrence. In no

event shall the total civil penalties imposed for multiple broadcasts of one particular campaign advertisement exceed \$10,000.

- A violation of Article 5 of Chapter 9.5 of Title 24.2 shall be subject to (i) a civil penalty not to exceed \$2,500.

Pursuant to §24.2-955.3, the State Board of Elections is notifying you via certified mail at least 10 days prior to the hearing. For more information, please visit the Department website: <http://www.elections.virginia.gov/board>.

Sincerely,

Tammy L. Alexander

<  Levin White for Sheriff
1 hr · 🌐

...

 A Safer Goochland
1 hr · 🌐



A great day at Goochland Day. A big "Thank You" to all who came out to learn how we can make A Safer Goochland!

This complaint is being filed against the Friends of Levin White 2019 campaign committee.

This picture was posted on Saturday, May 11, 2019, on candidate Levin White's "Levin White for Sheriff" and "A Safer Goochland"

political Facebook pages. The sign "A Safer Goochland" is his campaign slogan and the sign has no disclaimer on it.



The email from candidate for Sheriff Levin White was originally sent on June 11, 2019 and then re-distributed to the list seen in the email. This email DOES NOT contain a disclaimer, as required on electronic mail messages per section 14.1 of the "Summary of Laws and Policies Candidate Campaign Committees" - revised February 19, 2019.

From: Levin White <levinwhite2019@gmail.com>
Sent: Tuesday, June 11, 2019 10:36 AM
To: undisclosed-recipients:
Subject: A Safer Goochland - 2019 Sheriffs Election

Dear friend,

My campaign to become the next Goochland Sheriff is not one that was considered in a spur of the moment or because of opportunity. It has been carefully researched, planned and supported by key members of our community that are interested in Public Safety for ALL citizens.

Eighteen (18) months ago, I met with county leaders, business owners, residents including our commonwealth attorney. I listened and processed the information that was presented to me. It

was then that I realized that I needed to step up and offer my extensive experience as a law enforcement officer to the citizens living and working in Goochland County.

As we all know, eastern Goochland has explosive growth with commercial and residential development. We are also anticipating the development of a Truck Stop at the Gum Spring @ I64 exit. Additionally, Louisa County is developing/expanding their Industrial Park on our NW border at Shannon Hill.

Simply put, Goochland is no longer the quiet little county we all were accustomed to.

We have to be prepared for the dynamics that come with growing/developed counties bordering major cities like Metro-Richmond (Henrico, Chesterfield, Richmond).

With this growth, we will experience increased narcotics trafficking, human trafficking, burglaries, home invasions and unfortunately, violent crime.

Help me, help you and all of our citizens elect an experienced homicide, organized crime, public corruption, military veteran and violent crime investigator like myself that has been in the public safety business for 29 years.

I ask that you view and share my 2 minute video attached to this email and share this message with as many of your friends and family of Goochland County. I need your support in any way possible either through your sharing this message or by donation available through our website.

Thank you for reading my message,

Levin White

**Detailed
Description of
Violation**

Seen at the Deep Run Hunt Club horse show on Saturday, June 22, 2019, the attached picture shows an advertisement for Levin White for Sheriff (Goochland County) without a disclaimer of who paid for the ad.



LEVIN WHITE



for
GOOCHLAND COUNTY
SHERIFF



This complaint is being filed against the Friends of Levin White 2019 campaign committee.

This was an ad for Levin White for Sheriff, posted on Facebook by Randy Howard and Chris Howard on November 18, 2018. Levin

White was tagged in the post. As seen, this ad does not display the proper disclaimer.

Sent from Windows Mail

From: Levin White

Sent: Tuesday, July 9, 2019 8:57 AM

Dear Friends,

Your email address was referred to me by one of your friends. If you wish not to receive emails from my campaign, please respond and ask that it be removed. I hope each of you and your families had a wonderful Independence Day celebration. For those who do not know me and by way of digital introduction, my name is Levin White. I am a candidate to be your next Goochland County Sheriff. I won't bore you with a long read of how "great" I think I am over other candidates and not intended to denigrate my opponents, I will just provide some factual points below. Please review my 2 minute video on my website by clicking the link below or by copying / pasting into your web browser;

LevinWhiteforSheriff.com

<https://www.levinwhiteforsheriff.com/>

There are 3 Independent Candidates for sheriff. One candidate, (**Steve Creasey**) has local name recognition that has only experienced Goochland criminal behavior. As a uniform officer and supervisor of their communications office, this level of experience leaves ample room for needed experience. He has no investigative police experience except what he has gleaned from Goochland County Sheriffs Office in his 21 years of employment.

Another candidate, (**Emiel Fisher**) has never achieved certification as a police officer. Although he has run his own security company, we must not forget that there is a reason young men and women must attend a 6 month police academy just to be a police officer. It is a requirement. The security business is different from policing. If it were not, we would not need police officers.

I (**Levin White**) am a 29 year law enforcement veteran and a military veteran. I retired honorably after 20 years service as a Homicide, Organized Crime and Major Crimes Detective for the City of Richmond Police Department. I also have 9 years as a Special Agent working major fraud and public corruption investigations for the Commonwealth of Virginia. My wife of 20 years and I have 4 children and have lived in Goochland for 17 years.

Our county is experiencing explosive growth and we need a Sheriff in place that has the experience and know how to lead our public safety office. Our Commonwealth Attorney is supporting my candidacy and I hope you will join us as we move forward toward the election in November. Please view my 2 minute video and my "12 Point Plan" for Goochland on my website.

Please forward this to 10 of your friends in Goochland. If you do, we will have contacted 1000 voters with a simple click of the button.

Thank you for your time, and have a joyous summer!

Levin J. White **2019**

<https://www.linkedin.com/in/levin-white-cigi-vca-6b355686/>

Public Safety Professional, Special Agent - *Certified Inspector General Investigator*

Investigating Fraud, Waste, Abuse and Corruption

Active Member - *National Sheriffs Association, Rotary, American Legion, NAACP, NOBLE, Va. Crime Clinic, Association of Inspectors General (AIG)*

Association of Inspectors General (AIG)

Team Leader/Team Member - *National Association of Inspectors General - Peer Reviews in (Miami Dade, Fl, - Ft. Meyers Fl., - Polk County Fl., - Detroit, Michigan Public School System, - Commonwealth of Pennsylvania, Inspectors General)*

Retired Richmond City Police Detective

Extensive Experience in Homicide, Robbery, Major Crimes, Organized Crime, Vice/Narcotics and Public Corruption Investigations.

Military Service - *Virginia Army National Guard - 1st/183rd HHC 29th Light Infantry - Infantry Scout*

Levin White Response

Hello,

I received the letter indicating a complaint regarding possible violations of the Stand by your Ad Law (Chapter 9.5 of Title 24.2 of the Code of Virginia). I have reviewed all complaints and will be able to provide supporting documentation contrary to most of the complaints. I must say that I apologize immensely for this issue as, I take pride in executing action items correctly.

I have contacted your office as to the date reflected in the original correspondence indicates May 14 @1:00 is a date of the public meeting. I realize that is likely a typographical error and was advised the hearing date is set for August 6, 2019 @ 1:00pm. (1000 Bank Street, Senate Rm 3)

I have a conflict on the date of the hearing, as I have a job interview that very day in downtown Richmond and was advised to reserve 0900-1330 hrs. for the interview. The final time could not be determined until a later time.

So I request an alternate time and/or date to respond to this complaint.

Since my interview is downtown only a few blocks away, perhaps a hearing time of 2:30 or even 3:00 on August 6, 2019 would work?

If not, then the following day or week or alternate time that I can attend? I have cc: legal counsel in the event they are able to attend as well.

Thank you for this consideration and I am truly sorry this has occurred.

Levin White

804-874-8813

Thank you for ordering from SignsOnTheCheap.com!
Your Order Number is 680696

Make sure to print out this page or write down your order number for your records.
Here is a summary of the order you placed on 3/26/2011:

Billing & Shipping Information

Bill To:
Friends of Lloyd Banks
374 Sports Lake Road
Cumberland, VA, 23040
United States

Ship To:
Lloyd Banks
374 Sports Lake Road
Cumberland, VA, 23040
United States

Contact Info:
lloydortracy@gmail.com
540-538-5659

Shipping Method:
Ground

Your order should arrive by:
4/13/2011

Order Item Information

Item Description	Material	Size	Unit Price	Qty	Total
24"h x 10"w Wire Stake			\$0.99	51	\$50.49
Custom Sign - (Sign ID: 18631007)	Corrugated Plastic	18" x 24"	\$2.37	100	\$237.00

Please Note: Your stakes, frames, or accessories may ship sooner than your custom printed signs. Even if part of your order arrives early, rest assured that your signs will arrive by the delivery date listed above.

Payment Information

Payment Status: Complete	Summary of Charges:	
Visa: XXXXXXXXXXXXXXX0135	Subtotal:	\$287.49
	Shipping:	\$58.07
	Total:	\$345.56

This email is your receipt, so please print out a copy for your records. We'll email you a shipping notification as soon as your order is carefully packaged and on its way. If necessary, we'll send you additional shipping updates about your order.

Questions or concerns? Contact us at: service@signsonthecheap.com or 1-866-661-9239

This email was sent by: SignsOnTheCheap.com
11525B Stonehollow Dr., Suite 220 Austin, TX, 78758, USA

9. Lloyd Banks





COMMONWEALTH of VIRGINIA
DEPARTMENT OF ELECTIONS

Christopher E. "Chris" Piper
Commissioner

Jessica N. Bowman
Deputy Commissioner

July 23, 2019

Lloyd Banks, Jr.
374 Sports Lake Rd
Cumberland, Virginia 23040

Dear Lloyd Banks, Jr.:

The State Board of Elections is in receipt of a complaint regarding a possible violation of Virginia's Stand by Your Ad law (Chapter 9.5 of Title 24.2 of the Code of Virginia) by Lloyd Banks, Jr. . A copy of the challenged advertisement is included with this letter.

The State Board of Elections is holding a public meeting on Tuesday, August 6, 2019 at 1:00 P.M. to determine whether a violation has occurred and whether to impose civil penalties. You or a representative may attend and/or provide additional information to the Board that may be helpful in regarding this matter. You may also email a response to the complaint and/or information you would like the Board to consider to the Department of Elections Campaign Finance team at CFDA@elections.virginia.gov.

For more information about how the State Board of Elections adjudicates complaints regarding campaign advertisements, please refer to SBE Policy 2018-001, available online on the Department of Elections website:
<https://www.elections.virginia.gov/media/formwarehouse/Board-Policies/SBE-Policy-2018-001-StandByYourAdHearings.pdf>.

The meeting will be held in Senate Room 3 in the Virginia State Capitol, located at 1000 Bank St, Richmond, Virginia, 23219. To get to Senate Room 3, please enter through the main entrance to the Capitol building on Bank Street.

The Code of Virginia 24.2-955.3 provides the following:

- A violation of Article 2 of Chapter 9.5 of Title 24.2 shall be subject to (i) a civil penalty not to exceed \$1,000; or (ii) in the case of a violation occurring within the 14 days prior to or on the election day of the election to which the advertisement pertains, a civil penalty not to exceed \$2,500.
- A violation of Article 3 or 4 of Chapter 9.5 of Title 24.2 shall be subject to (i) a civil penalty not to exceed \$1,000 per occurrence; or (ii) in the case of a violation occurring within the 14 days prior to or on the election day of the election to which the advertisement pertains, a civil penalty not to exceed \$2,500 per occurrence. In no event shall the total civil penalties imposed for multiple broadcasts of one particular campaign advertisement exceed \$10,000.

- A violation of Article 5 of Chapter 9.5 of Title 24.2 shall be subject to (i) a civil penalty not to exceed \$2,500.

Pursuant to §24.2-955.3, the State Board of Elections is notifying you via certified mail at least 10 days prior to the hearing. For more information, please visit the Department website:
<http://www.elections.virginia.gov/board>.

Sincerely,

Tammy L. Alexander

Thank you for ordering from SignsOnTheCheap.com!
Your Order Number is 680696

Make sure to print out this page or write down your order number for your records.
 Here is a summary of the order you placed on 3/26/2011:

Billing & Shipping Information

Bill To: Friends of Lloyd Banks 374 Sports Lake Road Cumberland, VA, 23040 United States	Ship To: Lloyd Banks 374 Sports Lake Road Cumberland, VA, 23040 United States
Contact Info: lloydortracy@gmail.com 540-538-5659	Shipping Method: Ground
Your order should arrive by: 4/13/2011	

Order Item Information

Item Description	Material	Size	Unit Price	Qty	Total
24"h x 10"w Wire Stake			\$0.99	51	\$50.49
Custom Sign - (Sign ID: 18631007)	Corrugated Plastic	18" x 24"	\$2.37	100	\$237.00

Please Note: Your stakes, frames, or accessories may ship sooner than your custom printed signs. Even if part of your order arrives early, rest assured that your signs will arrive by the delivery date listed above.

Payment Information

Payment Status: Complete	Summary of Charges:
Visa: XXXXXXXXXXXX0135	Subtotal: \$287.49
	Shipping: \$58.07
This email is your receipt, so please print out a copy for your records. We'll email you a shipping notification as soon as your order is carefully packaged and on its way. If necessary, we'll send you additional shipping updates about your order.	Total: \$345.56

Questions or concerns? Contact us at: service@signsonthecheap.com or 1-866-661-9239



Banks Response

Dear Ms. Alexander,

Per your certified letter and our phone call of today, I am forwarding the below receipt to confirm my original purchase of campaign signs in March of 2011 when I originally ran for Supervisor.

I was elected in 2011, used the same signs purchased in 2011, a second time in 2015, was elected in 2015. I am now using the same signs a third time in 2019.

In addition to my signs being purchased in 2011 and before current requirements were mandatory, I previously added a label to both sides of each sign displayed per the attached photo example in an effort to avoid even the appearance of non-compliance.

Additionally in each campaign for election, including the current campaign, I have been in routine communication with our local registrar, Ms. Marlene Watson, to ensure adherence to all reporting requirements, policies, and laws. Earlier this summer I sought guidance from Ms. Watson to ensure compliance concerning this same matter.

I will add that there is a great deal of public sentiment in Cumberland surrounding the current election with the recent approval of a landfill in the county by the Board of Supervisors. There are individuals seeking to undermine the election process through the removal of my signs, assertion of campaign violations, and character assassinations

I am a retired military officer and I am currently employed as an accountant. I have no objection to following all applicable laws, requirements, and policies.

In my professional employments and election campaigns I have sought to be in full compliance. It has not been my intent to violate or circumvent any candidate or election requirements.

Sincerely,

Lloyd Banks

Cumberland District Two Supervisor,

and Candidate for Reelection

10. Patrick "Pat" Saylor





COMMONWEALTH of VIRGINIA
DEPARTMENT OF ELECTIONS

Christopher E. "Chris" Piper
Commissioner

Jessica N. Bowman
Deputy Commissioner

July 23, 2019

Patrick Pat Saylor
4292 Dry Valley Rd
Radford, Virginia 24141

Dear Patrick Pat Saylor:

The State Board of Elections is in receipt of a complaint regarding a possible violation of Virginia's Stand by Your Ad law (Chapter 9.5 of Title 24.2 of the Code of Virginia) by Patrick Pat Saylor. A copy of the challenged advertisement is included with this letter.

The State Board of Elections is holding a public meeting on Tuesday, August 6, 2019 at 1:00 P.M. to determine whether a violation has occurred and whether to impose civil penalties. You or a representative may attend and/or provide additional information to the Board that may be helpful in regarding this matter. You may also email a response to the complaint and/or information you would like the Board to consider to the Department of Elections Campaign Finance team at CFDA@elections.virginia.gov.

For more information about how the State Board of Elections adjudicates complaints regarding campaign advertisements, please refer to SBE Policy 2018-001, available online on the Department of Elections website:
<https://www.elections.virginia.gov/media/formswarehouse/Board-Policies/SBE-Policy-2018-001-StandByYourAdHearings.pdf>.

The meeting will be held in Senate Room 3 in the Virginia State Capitol, located at 1000 Bank St, Richmond, Virginia, 23219. To get to Senate Room 3, please enter through the main entrance to the Capitol building on Bank Street.

The Code of Virginia 24.2-955.3 provides the following:

- A violation of Article 2 of Chapter 9.5 of Title 24.2 shall be subject to (i) a civil penalty not to exceed \$1,000; or (ii) in the case of a violation occurring within the 14 days prior to or on the election day of the election to which the advertisement pertains, a civil penalty not to exceed \$2,500.
- A violation of Article 3 or 4 of Chapter 9.5 of Title 24.2 shall be subject to (i) a civil penalty not to exceed \$1,000 per occurrence; or (ii) in the case of a violation occurring within the 14 days prior to or on the election day of the election to which the advertisement pertains, a civil penalty not to exceed \$2,500 per occurrence. In no event shall the total civil penalties imposed for multiple broadcasts of one particular campaign advertisement exceed \$10,000.

- A violation of Article 5 of Chapter 9.5 of Title 24.2 shall be subject to (i) a civil penalty not to exceed \$2,500.

Pursuant to §24.2-955.3, the State Board of Elections is notifying you via certified mail at least 10 days prior to the hearing. For more information, please visit the Department website:
<http://www.elections.virginia.gov/board>.

Sincerely,

Tammy L. Alexander

Saylors Response Attachment

State Board of Elections

July 31, 2019

Ms. Alexander:

I was shocked to receive the registered complaint letter dated July 19, 2019 that I had done something wrong. I have never ran for any type of political office before and I threw my name in the hat at the last minute to run for the Republican nomination for Treasurer in Montgomery County in the Firehouse Primary election that was held on May 4th. I did not have any political experience prior to making this decision, I only did this in an effort to try and make a positive change in my county. I paid the required \$500 to run on April 1st and was told if I won the primary in May I could file the required paperwork in the Registrar's Office at that time. This is the only instruction I received as far as what was required. No one told me of any requirements about any flyers/signs I may create. I didn't know anything about running a campaign and did the best I knew trying to create a reasonable, fair ad. I paid for the signs (I didn't have very many) out of my own pocket (I don't have much money), I received no money from anyone. If I had known of the requirement I would have gladly complied with the regulation.

How is an ordinary person supposed to know these rules and regulations? I feel very let down by the entire process and lack of information I should have been aware of. Unfortunately, I learned a lot about local politics and how ugly the people and parties can be. I am just an average citizen and at this point I will NEVER run in any kind of election again. I am very sorry I wasn't aware of this regulation; I therefore am respectfully requesting this complaint against me be dismissed as I was not of aware of the regulation. Thank you for listening to me and I look forward to your reply.

Sincerely,

Patrick Saylors

plsaylors@verizon.net

540 230 1364

11. Friends of Rich Breeden LLC CC-19-00177



----- Forwarded message -----
From: Richard RobertsII <rgrii@yahoo.com>
Date: Thu, Apr 25, 2019 at 1:51 PM
Subject: Disclosure missing
To: <arielle.schneider@elections.virginia.gov>

Bringing this to your attention as a possible violation of code.



None of his cards that he is handing out have a disclosure statement.

Please confirm receipt.

Sent from my iPhone



COMMONWEALTH of VIRGINIA
DEPARTMENT OF ELECTIONS

Christopher E. "Chris" Piper
Commissioner

Jessica N. Bowman
Deputy Commissioner

July 23, 2019

Rich Breeden CC-18-00577
10605 King Eider Ct
Spotsylvania, Virginia 22553

Dear Rich Breeden:

The State Board of Elections is in receipt of a complaint regarding a possible violation of Virginia's Stand by Your Ad law (Chapter 9.5 of Title 24.2 of the Code of Virginia) by Rich Breeden CC-18-00577. A copy of the challenged advertisement is included with this letter.

The State Board of Elections is holding a public meeting on Tuesday, August 6, 2019 at 1:00 P.M. to determine whether a violation has occurred and whether to impose civil penalties. You or a representative may attend and/or provide additional information to the Board that may be helpful in regarding this matter. You may also email a response to the complaint and/or information you would like the Board to consider to the Department of Elections Campaign Finance team at CFDA@elections.virginia.gov.

For more information about how the State Board of Elections adjudicates complaints regarding campaign advertisements, please refer to SBE Policy 2018-001, available online on the Department of Elections website:
<https://www.elections.virginia.gov/media/formswarehouse/Board-Policies/SBE-Policy-2018-001-StandByYourAdHearings.pdf>

The meeting will be held in Senate Room 3 in the Virginia State Capitol, located at 1000 Bank St, Richmond, Virginia, 23219. To get to Senate Room 3, please enter through the main entrance to the Capitol building on Bank Street.

The Code of Virginia 24.2-955.3 provides the following:

- A violation of Article 2 of Chapter 9.5 of Title 24.2 shall be subject to (i) a civil penalty not to exceed \$1,000; or (ii) in the case of a violation occurring within the 14 days prior to or on the election day of the election to which the advertisement pertains, a civil penalty not to exceed \$2,500.
- A violation of Article 3 or 4 of Chapter 9.5 of Title 24.2 shall be subject to (i) a civil penalty not to exceed \$1,000 per occurrence; or (ii) in the case of a violation occurring within the 14 days prior to or on the election day of the election to which the advertisement pertains, a civil penalty not to exceed \$2,500 per occurrence. In no event shall the total civil penalties imposed for multiple broadcasts of one particular campaign advertisement exceed \$10,000.

- A violation of Article 5 of Chapter 9.5 of Title 24.2 shall be subject to (i) a civil penalty not to exceed \$2,500.

Pursuant to §24.2-955.3, the State Board of Elections is notifying you via certified mail at least 10 days prior to the hearing. For more information, please visit the Department website: <http://www.elections.virginia.gov/board>.

Sincerely,

Tammy L. Alexander

12. Friends of Scott Wyatt. CC-19-00177



Tell us WHERE and WHEN you saw the ad(s). Add additional pages if needed.

4x4 sign located at Pole Green Produce
at 6547 Pole Green Rd 33116. No
disclaimer on the sign seen on
June 16, 2019 at 7:34 AM. Pictures
attached



COMMONWEALTH of VIRGINIA
DEPARTMENT OF ELECTIONS

Christopher E. "Chris" Piper
Commissioner

Jessica N. Bowman
Deputy Commissioner

July 23, 2019

Scott Wyatt
P.O. Box 365
Mechanicsville, Virginia 23111

Dear Scott Wyatt:

The State Board of Elections is in receipt of a complaint regarding a possible violation of Virginia's Stand by Your Ad law (Chapter 9.5 of Title 24.2 of the Code of Virginia) by Scott Wyatt. A copy of the challenged advertisement is included with this letter.

The State Board of Elections is holding a public meeting on Tuesday, August 6, 2019 at 1:00 P.M. to determine whether a violation has occurred and whether to impose civil penalties. You or a representative may attend and/or provide additional information to the Board that may be helpful in regarding this matter. You may also email a response to the complaint and/or information you would like the Board to consider to the Department of Elections Campaign Finance team at CFDA@elections.virginia.gov.

For more information about how the State Board of Elections adjudicates complaints regarding campaign advertisements, please refer to SBE Policy 2018-001, available online on the Department of Elections website:
<https://www.elections.virginia.gov/media/formwarehouse/Board-Policies/SBE-Policy-2018-001-StandByYourAdHearings.pdf>.

The meeting will be held in Senate Room 3 in the Virginia State Capitol, located at 1000 Bank St, Richmond, Virginia, 23219. To get to Senate Room 3, please enter through the main entrance to the Capitol building on Bank Street.

The Code of Virginia 24.2-955.3 provides the following:

- A violation of Article 2 of Chapter 9.5 of Title 24.2 shall be subject to (i) a civil penalty not to exceed \$1,000; or (ii) in the case of a violation occurring within the 14 days prior to or on the election day of the election to which the advertisement pertains, a civil penalty not to exceed \$2,500.
- A violation of Article 3 or 4 of Chapter 9.5 of Title 24.2 shall be subject to (i) a civil penalty not to exceed \$1,000 per occurrence; or (ii) in the case of a violation occurring within the 14 days prior to or on the election day of the election to which the advertisement pertains, a civil penalty not to exceed \$2,500 per occurrence. In no event shall the total civil penalties imposed for multiple broadcasts of one particular campaign advertisement exceed \$10,000.

- A violation of Article 5 of Chapter 9.5 of Title 24.2 shall be subject to (i) a civil penalty not to exceed \$2,500.

Pursuant to §24.2-955.3, the State Board of Elections is notifying you via certified mail at least 10 days prior to the hearing. For more information, please visit the Department website:
<http://www.elections.virginia.gov/board>.

Sincerely,

Tammy L. Alexander

Wyatt Response

----- Forwarded message -----

From: **Scott Wyatt** <scott@votescottwyatt.com>

Date: Sat, Aug 3, 2019 at 5:25 PM

Subject: Stand By Your Ad - Response

To: cfda@elections.virginia.gov <cfda@elections.virginia.gov>

Dear Members of the Board,

Back in May, a complaint was filed regarding a campaign sign without a disclaimer. These signs were from a previous campaign with disclaimers written on the bottom. Since then we removed all signs that did not have printed disclaimers.

In early July, it was brought to my attention that a sign was placed by a supporter without a disclaimer on Pole Green Road. Once this was noticed by my campaign, I immediately had it removed and disposed of the sign.

Since May, my campaign has taken steps to dispose of all the signs from a prior Board of Supervisor's campaign. There should be no altered signs in the public, and my campaign has ordered all new signs that follow the Code of Virginia. Additionally, we have reached out to all volunteers that signs without disclaimers are not to be displayed and should be brought to the campaign office to be disposed.

Sincerely,
Scott Wyatt

2 Attachments



Scott Wyatt

Candidate for House of Delegates, District 97

E-Mail: Scott@VoteScottWyatt.com

Website: www.VoteScottWyatt.com

Phone: (804) 442-2737

P.O. Box 365
Mechanicsville, VA 23111

13. Virginia Constitutional Conservatives PAC-17-00698

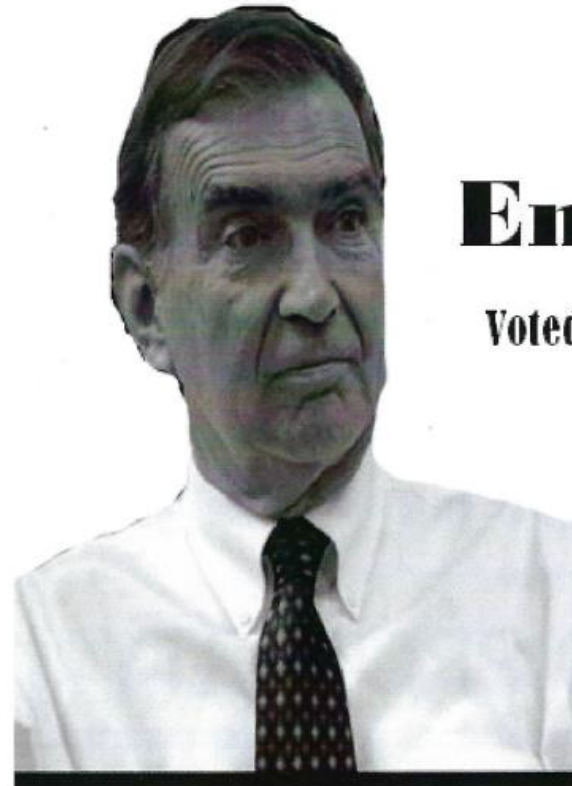

Your Neighbor

Senator

Emmett Hanger

Voted to Fund Millions to Planned Parenthood

To Kill Unborn Children

See you at the voting booth

JUNE 11, 2019

* Voted to Expand Obamacare and send millions for abortion



COMMONWEALTH of VIRGINIA
DEPARTMENT OF ELECTIONS

Christopher E. "Chris" Piper
Commissioner

Jessica N. Bowman
Deputy Commissioner

July 23, 2019

Virginia Constitutional Conservatives
11293 Allium Lane
Lovettsville, Virginia 20180

Dear Virginia Constitutional Conservatives:

The State Board of Elections is in receipt of a complaint regarding a possible violation of Virginia's Stand by Your Ad law (Chapter 9.5 of Title 24.2 of the Code of Virginia) by Virginia Constitutional Conservatives. A copy of the challenged advertisement is included with this letter.

The State Board of Elections is holding a public meeting on Tuesday, August 6, 2019 at 1:00 P.M. to determine whether a violation has occurred and whether to impose civil penalties. You or a representative may attend and/or provide additional information to the Board that may be helpful in regarding this matter. You may also email a response to the complaint and/or information you would like the Board to consider to the Department of Elections Campaign Finance team at CFDA@elections.virginia.gov.

For more information about how the State Board of Elections adjudicates complaints regarding campaign advertisements, please refer to SBE Policy 2018-001, available online on the Department of Elections website:
<https://www.elections.virginia.gov/media/formswarehouse/Board-Policies/SBE-Policy-2018-001-StandByYourAdHearings.pdf>.

The meeting will be held in Senate Room 3 in the Virginia State Capitol, located at 1000 Bank St, Richmond, Virginia, 23219. To get to Senate Room 3, please enter through the main entrance to the Capitol building on Bank Street.

The Code of Virginia 24.2-955.3 provides the following:

- A violation of Article 2 of Chapter 9.5 of Title 24.2 shall be subject to (i) a civil penalty not to exceed \$1,000; or (ii) in the case of a violation occurring within the 14 days prior to or on the election day of the election to which the advertisement pertains, a civil penalty not to exceed \$2,500.
- A violation of Article 3 or 4 of Chapter 9.5 of Title 24.2 shall be subject to (i) a civil penalty not to exceed \$1,000 per occurrence; or (ii) in the case of a violation occurring within the 14 days prior to or on the election day of the election to which the advertisement pertains, a civil penalty not to exceed \$2,500 per occurrence. In no

event shall the total civil penalties imposed for multiple broadcasts of one particular campaign advertisement exceed \$10,000.

- A violation of Article 5 of Chapter 9.5 of Title 24.2 shall be subject to (i) a civil penalty not to exceed \$2,500.

Pursuant to §24.2-955.3, the State Board of Elections is notifying you via certified mail at least 10 days prior to the hearing. For more information, please visit the Department website: <http://www.elections.virginia.gov/board>.

Sincerely,

Tammy L. Alexander

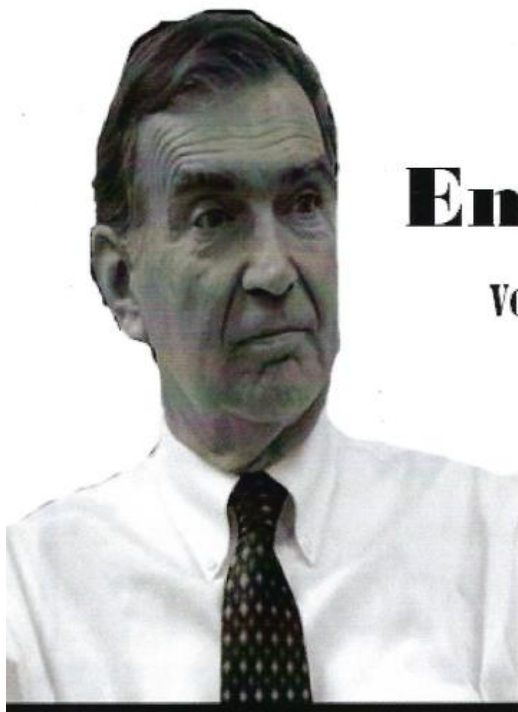

Your Neighbor
Senator
Emmett Hanger

**Voted THREE times to force you to pay
A TAX to bear arms.**

Had enough of Anti-Gun Emmett?

See you at the voting booth

JUNE 11, 2019

* Voted against Constitutional Carry in 2016, 2017 and 2019

Signs were posted on vehicles in a church parking lot while religious services were being held. This is a polling location but this site will not actually be used on June 11, 2019. Church officials are very disturbed by the distribution of 'unsolicited' printed election materials, which could result in the loss of this facility as a voting precinct.

Violation date 05-26-2019



**Constitutional
Conservatives**

LIFE, LIBERTY AND PROPERTY

Tammy,

Today in the mail I finally received the notice of the hearing set for tomorrow August 6th.

I was out of town on vacation in Florida and did not sign for the letter till last week upon return, and I just now have it in my possession.

As my office is in Hagerstown MD, and I work full time I cannot attend this meeting without putting my employment in jeopardy.

I am required to give 24 hours notice for any time to be missed at work.

If you see the date on the signed certified mail, you will realize I did not get this till today.

So I am asking you to reschedule the hearing so that I can attend.

I also questioning the validity of the complaint, as this was not a political ad favoring any candidate, but mearing informing the voters of the record of Senator Hanger. We did not coordinate with any campaign in any manner, but rather as citizens did our best effort to inform the voters.

I have all the roll call votes, his speeches and his efforts as we clearly stated in our flyers.

Keep in mind these flyers were not mailed, but rather handed out by volunteers, to inform residents of Senator Hanger's voting record, as protected by the 1st Amendment.

If we cannot reschedule the hearing, we will be forced to obtain counsel and appeal.

I understand the gravity of the issue, and I do want to attend so that I can defend our actions.

Nothing stated was untrue, roll call voting records clearing show that Senator Hanger voted against Constitutional Carry several years and not only that, but also voted for the Obamacare Expansion(Medicaid expansion) which funded Planned Parenthood...and he even voted against the Hyde Amendment, which would have prevented those funds from being used to fund abortion.

Again, I request a delay and rescheduling of the hearing and ask for the chance to defend our literature and free speech.

Thank you,
S. Chris Anders
Director
VCC
240-818-1284

Anders Response
received August 5, 2019
at 8:20 PM