



# COMMONWEALTH of VIRGINIA

Department of Health

DONALD R. STERN, M.D., M.P.H.  
ACTING STATE HEALTH COMMISSIONER

P. O. BOX 2448  
RICHMOND, VA 23218  
June 29, 1995

**MEMORANDUM**

**GMP #72**

**TO:** District Directors  
Environmental Health Managers/Supervisors/Specialists  
Office of Environmental Health Staff

**THROUGH:** Donald J. Alexander, Director *Donald J. Alexander*  
Division of Onsite Sewage and Water Services

**FROM:** Roger A. Cooley, *Roger A. Cooley* Asst. Technical Services Chief  
Division of Onsite Sewage and Water Services

**SUBJECT:** Mass Drainfield Reviews  
Sewage - Onsite - Plan Review

Attached are a memorandum dated September 10, 1984, from H. W. Oglesby, defining mass drainfields and stating those items which should be addressed by the applicant, and a memorandum from Robert W. Hicks, providing the procedures for handling mass drainfield reviews. This GMP was developed to clarify and update the procedures for handling mass drainfield submittals.

As noted in the April 5, 1988-memorandum, a proposal for a mass drainfield must address water mounding beneath the drainfield area, nitrate loading contamination, and the operational reliability of the system. Procedures and formulas for calculating mounding and nitrates have been previously submitted to the district offices (see May 12, 1988-memorandum from David D. Effert). Additional copies of this information will be sent upon request.

Previously, mass drainfield reviews were submitted to the Division for review by Technical Services. However, since Technical Services is staffed at 50% of its previous level, it will no longer review mass drainfields. However, as noted previously the applicant must address those items noted in previous memoranda. As a minimum the applicant must provide calculations indicating that water mounding does not encroach into the separation distance, that nitrate concentrations in the ground water will not exceed 10 mg/L, and that the system is operationally reliable. We should inform the applicant that we

GMP #72  
June 29, 1995  
Page 2

recommend that the nitrate concentration not exceed 5 mg/L which is the groundwater anti-degradation policy for nitrates set by DEQ. The local health department may review the mass drainfield calculations. Once the local health department has accepted the mass drainfield calculations and issued a construction permit, they should notify the Division by memorandum indicating the name, county, and design flow of the mass drainfield.

The drainfields and any dilution areas used for reducing nitrate concentration must be designated on a plan sheet. No future drainfields shall be placed in the dilution area unless an equivalent nitrate loading drainfield is taken out of service in the same area. Therefore, this plan sheet should be placed in the applicant's file for future reviews. Because of the increased possibility of system failures and the complexity of these systems Technical Services recommends that formal plans be submitted for mass drainfields.

GMP #72  
Sewage - Onsite - Plan Review



# COMMONWEALTH of VIRGINIA

C.M.G. BUTTERY, M.D.  
COMMISSIONER

Department of Health  
Richmond, Virginia 23219

May 12, 1988

N. W. REGIONAL OFFICE

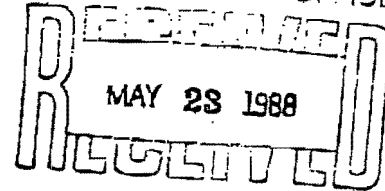

## MEMORANDUM

TO: Regional Managers ~~X~~  
District Sanitarians

FROM: David D. Effert D.D.S.,  
Technical Services Chief  
Bureau of Sewage and Water

SUBJECT: Mass drainfield criteria

Enclosed is the formula which can be used to estimate the nitrate concentration of groundwater near a mass drainfield. It is fairly self-explanatory. Also enclosed is information which can be used to predict water mounding under mass drainfields. Sample calculations are provided. The three formulas used to predict water mounding have been written into a basic computer program which is available from Charles Swanson of this department. He can be contacted at 786-5568.

If you have any additional questions, I can be reached at 786-1750.

/der  
Enclosure

**VDH**

*Swanson*  
*K.T.*

Proposed  
Mass Drainfield  
Regulations  
May 13, 1988

*Draft*  
N. W. REGIONAL OFFICE

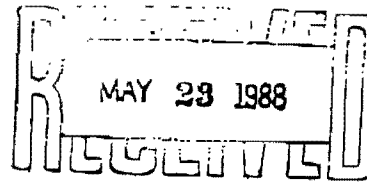

## Article 2. Definitions

"Drainfield Acre" - A drainfield acre shall typically be a four sided area, 43,560 square feet in extent, with the length of the shortest side being not less than 75% of the length of the longest side.

"Mass Sewage Disposal System" - a mass sewage disposal system is a sewage disposal system which will discharge effluent to a single absorption area, or multiple absorption areas, with or without combined flows, such that the loading rate exceeds 1,200 gallons per any drainfield acre per day. Detached single family residences with individual sewage disposal systems are exempt from this definition.

§ 4.32 Special Requirements for Mass Sewage Disposal Systems. The criteria in this section apply to mass sewage disposal systems and shall supersede any other conflicting criteria contained elsewhere in these Regulations. Design criteria not specifically covered in this section shall be taken from the appropriate sections of these Regulations.

A. Ownership of a mass sewage disposal system shall be the same as described in section 3.13.05.

B. Mass sewage disposal systems shall be considered Type II Systems requiring formal plans and specifications.

C. Mass subsurface sewage disposal system shall be designed using low pressure distribution.

D. Separate reserve areas(s), meeting the requirements of the original absorption area(s), and equaling 100% of the required area, shall be provided adjacent to the proposed system.

E. The prevention of groundwater contamination shall be addressed by the applicant. Documentation shall include but not be limited to how nitrate-nitrogen concentrations in the groundwater will be reduced to 5 mg/l or less at the perimeter of the project.

F. The potential for effluent mounding below the absorption area shall be addressed by the applicant. Data shall be submitted which will demonstrate how a minimum of two feet of unsaturated soil will be maintained below the trench bottom.

G. In addition to the subsurface absorption system protection provided for in sections 8.05 and 8.05.06, a dedication document duly recorded with the Clerk of the Court shall be furnished to the Department stating that the sewage disposal system area(s) and reserve area(s) will be used only for sewage renovation and may not be used for excavation or permanent structures, while the mass sewage disposal system is utilized.

H. Groundwater, soil, and effluent sampling may be required on a case-by-case basis. Whenever a water supply or supplies are located down gradient from a mass sewage disposal system(s), at least one monitoring well shall be required between the water supply and the mass sewage disposal system.

Sampling parameters and frequency shall be established by the Department on a case-by-case basis.

Note the correction to the first equation.

The following outlines the calculations necessary to determine the impact of a mass drainfield on the nitrate concentration of groundwater. It is based on the concept of mass balance. The following assumptions are made:

1. The ammonia concentration of the wastewater is 65 mg/l. This value is based on an average ammonia concentration for domestic wastewater as reported in the EPA manual "Design of Onsite Wastewater Treatment Systems."
2. Of the 65 mg/l of ammonia, 50 percent is volatilized or otherwise lost. According to EPA, 99 percent of the rest is converted to nitrate under aerobic conditions. For calculation purposes, it is assumed that 30 mg/l of nitrate is available in domestic wastewater.
3. The average rainfall in the state is 43 inches per year. Of this, 20 inches per year infiltrates into the ground and is added to the groundwater. This assumes normal vegetation. Slope is not taken into account. If there are buildings or a paved parking lot, these areas are subtracted from the dilution area. Gravel parking lots have an estimated 5 inches of infiltration per year as estimated by the Soil Conservation Service. The system owner must own or control by legal easement the dilution area.

The following variables are needed to calculate the concentration of nitrate in the groundwater.

Dilution area (in acres) = D

Absorbed rainfall (in inches) = R (typically 20 inches)

The calculation of the groundwater nitrate concentration is a two step process. The first step involves determining what the dilution rate from rain water will be. This can be calculated with the following formula:

$$R \frac{\text{inches}}{\text{year}} \times \frac{\text{ft.}}{12 \text{ inches}} \times 3.259 \frac{\text{gal}}{\text{Ac ft.}} \times D \text{ acres} \times \frac{1 \text{ year}}{365 \text{ days}} = \text{dilution (gal)}$$

Knowing the number of gallons of wastewater produced per day, the nitrate concentration of the groundwater leaving the property can be calculated as follows:

$$\frac{\text{No. of gallons of wastewater} \times 30 \text{ mg}}{\text{No. of gallons of ww} + \text{dilution}} = \text{concentration, mg/l}$$



# COMMONWEALTH of VIRGINIA

Department of Health  
Richmond, Va. 23219

JAMES B. KENLEY, M.D.  
COMMISSIONER

September 10, 1984

MEMORANDUM:

TO: All Regional Medical Directors  
Health Directors (at Headquarters Offices) and  
Division of Water Programs

FROM: H. W. Oglesby, Assistant Commissioner  
Office of Management for  
Community Health Services *H. W. Oglesby*

ATTENTION: All Holders of the "Manual for Implementation of the  
Sewage Handling and Disposal Regulations."

Enclosed with this memorandum is an expanded definition of § 3.13.b "Procedures for obtaining a Construction Permit for a Sewage Disposal System - Type II."

Please require all sanitarians to comply with the attached official agency definition. Please see that all holders of the "Manual for Implementation of the Sewage Handling and Disposal Regulations" in the local health department in your district or regional office are furnished with a copy of this information and their manuals are revised as indicated. Also, be sure to revise the official office copy.

P.P.I. #6.31, "Mass Drainfields (Subsurface Soil Absorption Systems Designed for Average Daily Sewage Flows in Excess of 2000 Gallons)" expires upon receipt of this notice.

HWO:fh  
enclosure

cc: Regional Sanitarians  
District Sanitarian Supervisors



EXPANDED DEFINITION OF TYPE II, SEWAGE

DISPOSAL SYSTEMS, § 3.13.b

Reference 3.13.b Type II:

Type II Sewage Disposal Systems which meet the following definition, are considered mass drainfields:

A sewage disposal system which will discharge effluent to a single absorption area or multiple absorption areas with or without combined flows such that:

- 1) The loading rate exceeds 1,200 gallons per day for any acre, or
- 2) The disposal system contains more than 2,000 linear feet of percolation piping.

Detached single family residences with individual sewage disposal systems are exempt from this definition.

It is the policy of the Department to discourage the use of mass drainfields. When they are proposed, it is recommended that the potential for saturated soil conditions below the disposal area (water mounding), the expected nitrate loadings to the water table and the operational reliability of the system be addressed by the applicant(s).

The rationale for utilizing a 1200 gpd/ac loading rate is based upon limiting nitrate concentrations to below 10 mg/l in groundwaters, EPA's primary maximum contaminant level allowed in drinking water. The rationale for limiting system size to 2000 linear feet is based upon dividing the 1200 gpd loading rate by the volume of a four inch percolation line (.6 gal per linear foot).



# COMMONWEALTH of VIRGINIA

C.M.G. BUTTERY, M.D.  
COMMISSIONER

*Department of Health*  
*Richmond, Virginia 23219*

April 5, 1988

## MEMORANDUM

TO: Regional Directors  
District Directors  
Regional Sanitarians  
District Sanitarians

THROUGH: Robert B. Stroube, M.D., M.P.H. *RBS*  
Deputy Commissioner for  
Community Health Services

FROM: Robert W. Hicks *RWH / by JSA*  
Director  
Division of Sanitarian Services

SUBJECT: Nitrate Loading and Water Mounding in Mass Drainfields

The Division of Sanitarian Services recently has received several inquiries from field staff regarding the Department's procedure for evaluating mass drainfield proposals. Attached for your reference is a copy of the September 10, 1984 memo from H. W. Oglesby stating those items which must be addressed by the applicant.

When someone proposes a mass drainfield (as defined in the September, 1984 memo) their proposal must address water mounding beneath the drainfield area, nitrate loading contamination, and the operational reliability of the system.

When a large volume of liquid waste is applied to a small area of land the potential exists for significantly raising the watertable. If the watertable rose to the level of the absorption trench, or higher, renovation of sewage effluent would not be possible because of anaerobic conditions that would occur in the saturated soil. In addition, the migration of bacteria and viruses would be aided by saturated anaerobic soil conditions. The possibility of the system failing, either overtly or covertly, is much greater than that of it working properly.

The failure of a sewage disposal system may result in partially treated human waste being exposed on the ground's surface or moving to ditches or streams. The exposure of humans to this partially treated waste greatly increases the potential for contracting any of several diseases including, but not limited to, salmonellosis, shigellosis, viral hepatitis A, and amebiasis (See Dr. Buttery's memo to district and regional directors dated August 1, 1986).

Nitrate, although a naturally occurring form of nitrogen, is of particular concern in drinking water. High nitrate levels in drinking water can cause methemoglobinemia (infant cyanosis or "blue baby" disorder) which interferes with the capacity of an infant's blood to carry oxygen. The federal drinking water standard for nitrate is 10 mg/l (as expressed as nitrogen). The level is also 10 mg/l in the Virginia Waterworks Regulations. For this reason, the Department has adopted the drinking water standard as the maximum level for groundwater at the perimeter of a mass drainfield. In addition, the Virginia State Water Control Board has a groundwater anti-degradation policy which limits the nitrate level in groundwater to 5 mg/l.

Section 3.17.01 of the Sewage Handling and Disposal Regulations states (emphasis added);

3.17.01 If it is determined that the proposed design is inadequate or that soil, geological or other conditions are such to preclude safe and proper operation of a proposed sewage disposal system or that the installation of the system would create an actual or potential health hazard or nuisance, the permit shall be denied and the owner shall be notified in writing of the basis for the denial. The notification shall also state that the owner has the right to appeal the denial.

As stated above, the mounding of the watertable beneath the absorption site can lead to failure of the system which may result in the transmission of disease. Also, the presence of nitrates in drinking water poses a threat to the lives of infants. By requiring the applicant to address these issues during the plan review stage the potential for installing a system which creates a health hazard or nuisance is reduced.

In order to assist you in the future, all plans for mass drainfields and documents pertaining to § 3.13.05 must be submitted to this office for review and approval before any permit is issued by the Department. Local health department staff must be cautioned not to make any kind of commitment, verbal or written, for the approval of a permit to construct a mass drainfield without the approval of the Bureau of Sewage and Water.

Should you have any questions please call Gary Hagy at 786-1750.

**CALCULATING THE NITRATE CONCENTRATION  
IN GROUND WATER BELOW  
MASS DRAINFIELDS**

Bureau of Sewage and Water  
Commonwealth of Virginia  
Department of Health  
November 1, 1988

## **Introduction**

Published reports have recently been reviewed by the Bureau of Sewage and Water in an attempt to more accurately predict the impact of a mass drainfield on the concentration of nitrate in the ground water. As a result of this review, the method of estimating the ground water nitrate concentration has been modified slightly to reflect what is currently known.

### **A Two Step Process**

The following description explains the two step process which is used to estimate the nitrate concentration of ground water near a mass drainfield. The first step estimates the amount of rain water which infiltrates into the ground and dilutes the nitrate. The second step uses a mass balance equation to estimate the ground water nitrate concentration.

## **Step I**

### **Calculating Rainwater infiltration**

#### **The Formula**

There are a number of ways of calculating rainwater infiltration. For consistency, we are using the following formula. The number 74 is a constant that converts the input information to gallons per day.

#### **Equation I**

$(R) \times (D) \times (74)$  average gallons of dilution rain water per acre per day

Where:

R = absorbed rainfall in inches

D = Acres available for infiltration of the rain

#### **An Explanation of the Variables**

The absorbed rainfall (R) is the number of inches of rain which infiltrates into the ground. Typically, this will be 50 percent of annual rainfall according to the Soil Conservation Service. Other values can be used if justified by the SCS Runoff Curve Number. Virginia has an average annual rain fall of 40-42 inches according to the National Oceanic and Aerospace Administration, so (R) would be about 20 inches. Some areas of the state receive more rainfall than the average of 40 inches. Data to that effect will be reviewed. Also, very flat areas may absorb more than the 50 percent average. Data from the Soil Conservation Service Runoff Curve Number is reviewed on a case by case basis if a consultant believes that 20 inches of rain water infiltration is not a correct value.

The dilution area (D) is the area where rain can infiltrate into the soil and dilute the nitrate in the ground water. Typically, it is the adjacent area owned, or controlled with an easement, by the system owner. The dilution area does not include the area under buildings, paved parking lots and other impermeable facilities unless provisions are made to return the runoff from these facilities into the ground water. No structures can be built on the dilution area for the life of the soil absorption field. A plat must be provided by the en and the dilution area must be clearly marked off. Any existing or proposed buildings must also be shown on the plat.

Special cases sometimes occur where the infiltrative capacity of the dilution area has been modified. A gravel parking lot is a good example of a modified infiltrative surface. For the purpose of determining infiltrative area, the Soil Conservation Service reports that gravel parking lots absorb 70% of the rainfall. Other values for other modified surfaces will be reviewed, based on the SCS Runoff Curve Number on a case by case basis.

## **Step 2**

### **Mass Balance Calculation**

Once the average number of gallons of infiltrated rainfall is calculated, step two, the mass balance calculation, can be done. To use the mass balance approach the following information must be known:

1. The number of gallons of wastewater equivalent to the amount of nitrate being produced (see explanation below).
2. The nitrate concentration of the wastewater.

### **Nitrate Equivalent**

Soil absorption fields are hydraulically sized based on water use as listed in Table 4.6 of the Sewage Handling and Disposal Regulations. However, the nitrate concentration data that we are using is based on flows less than those shown in Table 4.6. An adjustment must be made when you are estimating the potential amount of nitrate being produced.

NOTE: This downward adjustment is only done when nitrate concentrations are being calculated. The hydraulic sizing of the system is based on the information in Table 4.6 of the Sewage Handling and Disposal Regulations.

For the purpose of calculating the nitrate equivalent loading rate for residential buildings, use 65 gpd/person. Remember there are two people per bedroom. The equivalent nitrate loading rate for a restaurant is 20 gpd/seat. The nitrate equivalent loading rate for other establishments will be determined at a future date.

## Nitrate Concentration

The potential nitrate concentration is based on an average ammonium ion concentration of 60 mg/l for residential wastewater (EPA, 1980). Fifty percent of this is volatilized, or otherwise lost before it gets into the water table as nitrate. Ninety-nine percent of the rest of the ammonium ion is converted to nitrate under aerobic conditions (EPA, 1980). Therefore, for our purposes, 30 mg/l of potential nitrate is present in residential wastewater. Other studies (Siergist, et. al, 1984) reported that restaurant wastewater has only 80 percent of the nitrogen present in residential wastewater, so we use a potential nitrate concentration of 24 mg/l for restaurant wastewater. Recall that this is based on 20 gpd/seat for the purposes of estimating the nitrogen loading rate for a restaurant.

## Mass Balance

We can estimate the number of gallons of rainwater which infiltrates into the ground on average each day. Further, we can estimate the average number of gallons of wastewater produced each day, and the potential nitrate concentration of the wastewater. With this information, we can estimate the nitrate concentration of the ground water leaving the property using a mass balance concept and the following equation:

### Equation 2

$$\frac{\text{No. of gallons of wastewater}}{\text{No. of gallons of ww + dilution}} \times \text{concentration of the wastewater} = \text{nitrate concentration of the aquifer in mg/l}$$

## Interpreting the Results

The nitrate concentration of the aquifer should not exceed 10 mg/l. This level was established based on EPA drinking water standards. The level may be changed to 5 mg/l (proposed Department of Health mass drainfield regulations) to allow for a margin of safety.

## Recommendations

If the calculations show that the nitrate concentration in the ground water exceeds 10 mg/l, the engineer has the following options:

1. Increase the size of the dilution area.
2. Reduce the nitrate loading rate by producing less wastewater. This would have to be an actual reduction in use i.e., fewer bedrooms or fewer seats in a restaurant. The use of low flush toilets reduces the hydraulic load, but the amount of nitrogen produced per year stays the same.
3. Provide some method of reducing the potential nitrate concentration of the wastewater. This would require treatment which removes the ammonium ion.

4. Submit detailed documentation which shows that rainfall exceeds the state average, that infiltration is greater than 50 percent of rainfall, or that the potential nitrate concentration of the wastewater is less than average.

### **Example Nitrate Concentration Problem**

The following is an example calculation to estimate the ground water nitrate concentration near a mass drainfield.

- Information provided by the engineer:
- Rainfall, R = 40 inches per year
- Percent of rainwater which infiltrates, 50 percent
- Dilution area, D = 5 acres
- Type of wastewater, residential
- Number of bedrooms, 12
- (Three homes with 4 bedrooms per home all disposing to a common drainfield)
- Hydraulic loading rate 150 X 12 = 1800 gallons
- Equivalent nitrate loading rate = 130 X 12 = 1560 gallons
- Potential nitrate concentration 30 mg/l (residential waste)
- 

Step 1: Calculate R, the number of inches of rain that infiltrate the site per year.

$$R = 40 \text{ inches/year rainfall} \times 0.5 = 20 \text{ inches per year}$$

Step 2: Use equation one to calculate the average daily dilution from rainwater.

$$20 \text{ inches} \times 5 \text{ acres} \times 74 = 7400 \text{ gallons per day per acre year}$$

Step 3: Use equation two to calculate the nitrate concentration leaving the site.

$$1560 / (1560 + 7400) \times 30 \text{ mg/l} = 5.2 \text{ mg/l}$$

This value of 5.2 mg/l will not exceed the ground water nitrate standard of 10 mg/l.

Note: If this were a restaurant, the equivalent nitrate loading rate would be based on 20 gpd/seat and the potential nitrate concentration would be 24 mg/l.

#### References

Environmental Protection Agency, 1980. Design Manual-Onsite Wastewater Treatment and Disposal. EPA Publication No. 625/1-80-012.

Siegrist, R.L, D. L. Anderson, and J. C. Converse, 1984. Commercial Wastewater On-Site Treatment and Disposal. Proceedings of the Fourth National Symposium on Individual and Small Community Sewage Systems. ASAE Publication No. 07-85. p. 217.



# ANALYSIS OF WATER TABLE MOUNDING AND RECOMMENDATIONS FOR MASS DRAINFIELD DESIGN

J. C. Parker  
November 22, 1982

## 1. Limitations of approaches

Any analysis of water movement in soils and underlying geologic materials is of necessity approximate at best due to the complex geometry and large variability of earth materials. One imposes many simplifications on reality to simplify its mathematical representations and hopes they are not so unreasonable as to render the results useless. Field verification is ultimately necessary to justify any such hopes. This report outlines approximate methods of estimating water table mounding and checks the predictions against field-measured data where feasible. The approach taken is purely analytical and accordingly is restricted to simple boundary conditions, geometries and soil conditions. Suggestions for dealing with more complex situations are given to extend applicability of the method.

A more precise analysis of such problems could be made using various numerical approaches. There are a number of computer codes available for the analysis of this sort of problem and it would be advisable to consider their use for final design or at least to evaluate the analytical methods by selective comparisons with numerical solutions. Numerical analysis would also make the evaluation of solute transport accompanying wastewater disposal feasible. The analytical approach given here considers only groundwater mounding.

## 2. Analytical methods

### 2.1 Perched groundwater mounds on level strata

Brock (1982) reports a solution for the problem of perched groundwater mounds beneath strip recharge basins shown in Fig.1 based on the Dupuit-Forchheimer assumptions. For a strip basin of width  $L_e$  with a flux density  $q$  (volume per unit time per unit area) and for conductivities in the upper and lower layers of  $K_1$  and  $K_2$  respectively ( $K_1 > K_2$ ), the steady-state mound height is given by:

$$H_0 = \frac{L_e}{2} \left[ \frac{q^2}{K_1 K_2} - \frac{q}{K_1} \right]^{1/2}$$

Equation 1

Comparisons with numerical solutions indicate Eq. 1 is reasonably accurate if  $K_1/K_2 > 10$  and  $q/K_1 < 0.2$ .

In reality flow will not be strictly two-dimensional.. For a drainfield of width  $L_c$  and length  $L_f$ , Eq. 1 is valid with  $L_e = L_c$  only if  $L_f \gg L_c$ . If  $L_c = L_f$  using  $L_e = L_c$  in Eq. 1 will cause  $H_0$  to be in error due to the fact that flow in the third dimension is not accounted for. For a given  $L_c$  and  $H_0$  the square may be expected to accommodate about twice the flux density of a long strip. However, altering the ratio  $L_f/L_c$  changes the flux density at constant effluent volume since by definition

$$q = J/L_c (L_f)$$

Equation 2

where  $J$  is the total volume of effluent added per unit time. As a result, at constant  $q$  (hence at constant field area for a given  $J$ ) employing  $L_e = L_c$  in Eq.1 will underestimate  $H_0$  for the square field. These effects may be accommodated by taking  $L_e$  in Eq. 1 as an “effective” width equivalent to that for the 2-D case and calculating it .

$$L_e = L_c \left| \frac{L_f^2 + L_c^2}{L_f^2} \right|^{1/2}$$

Equation 3

Defining the geometric factor  $a$  as

$$a = L_f/L_c$$

Equation 4

Yields for Eqs. 2 and 3:

$$L_e = L_c \left| \frac{1 + a^2}{a^2} \right|^{1/2}$$

Equation 5

$$a = J/aL_c^2$$

Equation 6

Combining equations 1, 5 and 6 gives

$$H_0 = \frac{(1 + \alpha^2)^{1/2}}{2 \alpha^2} \left[ \frac{J^2}{K_1 K_2 L_c^2} - \frac{\alpha J}{K_1} \right]^{1/2}$$

Equation 7

which may be employed to evaluate mounding caused by groundwater perching over a fine layer if no permanent water table exists under natural recharge conditions.

The lateral extent of the perched mound from the drainfield perimeter ( $L_d$ ) may be calculated as:

$$L_d = \frac{qL_c}{K_2} - \frac{L_c}{2}$$

Equation 8

$$L_d = J/aL_cK_2 - L_c/2$$

Equation 9

## 2.2 Groundwater mounds on permanent level water tables

The preceding analysis is directly applicable only for perched ground water mounds. We may extend the analysis for mounding on permanent water tables if we make some further assumptions. We assume a uniform conductivity  $K_1$  in the natural vadose zone (above the water table). We regard the ratio  $K_1/K_2$  to reflect the ability of the aquifer to dissipate the additional hydraulic load laterally. Specifically, we take the ratio of lateral to vertical impedance to be reflected by the ratio of the lateral to vertical mound dimensions giving:

$$\frac{K_1}{K_2} = \frac{L_d + L_c/2}{H_0}$$

Equation 10

Substituting Eq. 10 into Eq. 7 gives

$$\frac{(1 + \alpha^2)^{1/2}}{2 \alpha^2 K_1} \left[ \frac{J^2 L_d}{H_0 L_c^2} + \frac{J^2}{2H_0 L_c} - \alpha J K_1 \right]^{-1/2} - H_0 = 0$$

Equation 11

In certain instances,  $L_d$  may be clearly defined by site conditions as for example when artificial drainage is to be installed or when a natural seepage face seems likely. Often  $L_d$  will not be clearly defined. An approximation of  $L_d$  may be obtained in such cases using the empirical relation:

$$L_d = L_c^2/4W - L_c/2$$

Equation 12

where  $W$  is the aquifer thickness.

### 2.3 Groundwater mounds on sloping strata

Groundwater mounding in tilted aquifers (Fig. 3) may be evaluated analytically using the Dupuit-Forchheimer assumptions to give:

$$L_c = \frac{2JL_d (1 + \alpha^2)^{1/2}}{\alpha K_1 N} \left[ H_0^2 + H_0(2W + L_d S) + 2L_d WS \right]^{-1}$$

Equation 13

where  $W$  is the mean aquifer thickness;  $S$  is the fractional slope;  $K_1$  is the conductivity of the homogeneous aquifer above an impermeable lower surface;  $N$  is a correction factor depending on the drainfield location on the slope; and the other terms are as previously defined.

The derivation of Eq. 13 assumes all water flows down slope and gives  $N = 1$ . This will always be the case when the difference between the elevation of the drainfield and the local topographic high is greater than the soil depth. When this is not the case,

some water may flow “upslope” across the drainage divide. We may accommodate this possibility approximately by employing the factor N evaluated by:

$$N = 1 \quad (B/Z = 1)$$

$$N = 2 - B/Z \quad (B/Z < 1)$$

Equation 14

where B is the difference in elevation between the local topographic high and the average elevation of the drainfield and Z is average soil depth (to the impermeable lower boundary).

An expression analogous to Eq. 12 is postulated to estimate Ld:

$$L_d = \frac{L_c^2}{2WN} - \frac{L_c}{2}$$

Equation 15

Combining Eqs. 13 and 15 eliminates the unknown Ld. If the calculated value of Ld exceeds physical limits imposed by topography then the lower value should be employed in Eq.13.

### 3. Application of theory

A summary of the analytical models for estimating groundwater mounding is given in Fig. 4. Cases 1 and 2 are for approximately level sites, i.e., less than 5-10%. “Site” should be taken, to mean the drainfield plus a surrounding area within about 2Lc to 3 Lc from the drainfield perimeter. Case 1 applies when no permanent water table exists above a high impedance layer and Case 2 applies when one does exist. A “high impedance layer” may be functionally defined as the first layer beneath the drainfield lines which has a saturated conductivity less than about 10<sup>-4</sup> m/day or is less than an order of magnitude of that of the overlying layer. Cases 3 and 4 are for sloping sites where B/Z is less than a or greater than 1, respectively.

In all cases, hydraulic conductivities and soil and aquifer thicknesses employed in the equations should represent spatial average values. If layer thicknesses and conductivities are evaluated at k locations on the site, the mean site conductivity of layers m to n (e.g. the aquifer) may be calculated as

$$\bar{K} = \frac{\sum_{j=1}^k \sum_{i=m}^n L_{ij} K_{ij}}{\sum_{j=1}^k \sum_{i=m}^n L_{ij}}$$

Equation 16

where j is the location number (horizontal index) and i is the layer number (vertical index) and L and K are the layer thickness and conductivity. Simple means of aquifer thicknesses and water table depths over the site may be calculated for use in the equations.

Examples of the various calculations follow.

### 3.1 Case 1: Level perched table

A drainfield is desired to dispose of 25 m<sup>3</sup> /day (~6500 gal/day) of effluent on a level site. Site investigation indicates

Bore Hole 1		Bore Hole 2		Bore Hole 3	
Depth (m)	K(m/day)	Depth (m)	K(m/day)	Depth (m)	K(m/day)
0.5-2.0	0.05	0.5-3.5	0.10	0.5-1.5	0.08
2.0-6.0	0.15	3.5-5.0	0.05	1.5-4.5	0.10
6.0+	0.001	5.0+	0.002	4.5+	0.0005

The perching strata is the third layer with average depth and conductivity:

$$D = (6 + 5 + 4.5)/3 = 5.2 \text{ m}$$

$$K_2 = (0.001 + 0.002 + 0.0005)/3 = 0.0012 \text{ m/day}$$

The value of K1 is calculated by Eq. 16 as:

$$K = \frac{(2 - 0.5)(0.05) + (6 - 2)(0.15) + (3.5 - 0.5)(0.1) + (5 - 3.5)(0.05) + (1.5 - 0.5)(0.08) + (4.5 - 1.5)(0.01)}{(6.0 - 0.5) + (5.0 - 0.5) + (4.5 - 0.5)}$$

$$= 0.102 \text{ m/day}$$

With the drainfield installed 0.5 m deep, the maximum value of  $H_0$  to keep the mound 0.5 m below the lines is  $5.2 - 1.0 = 4.2$  m. Assuming a square drainfield ( $a = 1$ ) Eq. 7 gives  $L_c$  135 m and from Eq. 9 the lateral extent of the perched mound from the drainfield perimeter ( $L_d$ ) is 87 m. For  $a = 5$  we obtain  $L_c = 45$  m and  $L_d = 78$  m. This indicates an approximately 50% reduction in field area ( $aL^2$  equals  $18225 \text{ m}^2$  to  $8820 \text{ m}^2$  respectively) when the field is elongated rather than square. This will generally be found to occur.

### 3.2 Case 2. Level unconfined aquifer

Data reported by Ali and Chan (1982) on a mass drainfield in Ontario may be used to evaluate the analytical solution for this case. The site was nearly level and the soil WAS 9-15 m to bedrock (average value 12 in). A permanent water table occurred which fluctuated seasonally between 1.5 and 3.0 m in depth (average 2.0 m). Thus we have  $D = 2.0$  m and  $W = 10.0$  m. The hydraulic conductivity of the soil was measured in situ using three methods and also in the lab on core samples. The large diameter rising and falling head auger hole tests below the water table gave average  $K$  values of 0.20 and 0.44 m/day, respectively. Constant head tests with driven well points gave values about 10 times lower as did laboratory tests on core samples. Percolation tests at a depth of 1 m incidentally gave rates of 0.56 min/inch or 65 m/day -- over 100 times the conductivity! Loading rates ( $J$ ) were maintained at 41 m<sup>3</sup>/day (~10,600 gal/day) through the summer and fall over a field area 84 by 64 ( $L_c = 64$  m,  $a = 1.3$ ).

From Eq. 12 we find  $L_d = 70$  m which is in reasonable agreement with field measurements of water table fluctuations in the vicinity of the drainfield. Solving Eq. 11 by trial using  $K_1 = 0.20$  m/day gives  $H_0 = 3.3$  m. Using  $K_1 = 0.44$  m/day gives  $H_0 = 1.6$  m. The measured water table mounding was 1.5 m which agrees well with the value predicted using the larger  $K$  value.

### 3.3 Case 3: Sloping site near hilltop

A drainfield is desired to dispose of 25 m<sup>3</sup> (~6,500 gal/day) of effluent on a site located on a side slope. The average elevation of the site is 500 m above sea level. The top of the hill is at 507 m elevation ( $B = 7$  m) and the bottom of the is 100 m down slope on the horizontal. The soil is 10. m deep to nearly impermeable bedrock ( $Z = 10$  in). Accordingly  $B/Z = 0.7$  and  $N = 2 - B/Z = 1.3$ . The soil has an average conductivity (via Eq. 16) between the drainfield lines and bedrock of 0.1 m/day. The average slope of the site is 15% ( $S = 0.15$ ).

A natural water table occurs at 6 m ( $W = 10 - 6 = 4$  m). To keep the mounding at least 1 m below the soil surface we have a maximum value for  $H_0$  of 5 m. Assuming a rectangular drainfield with  $a = 4$  and solving Eqs. 13 and 15 by trial gives  $L_c = 41$  m and  $L_d = 141$  m. However since it is only 100 m to the bottom of the hill  $L_d$  should not be taken greater than this. Fixing  $L_d$  at 100 m in Eq. 13 gives  $L_c = 38$  for a field area of  $aL_c^2 = 5800$  in ( 1.4 acres).

### 3.4 Case 4: Sloping site below hilltop

Considering the same situation as in Case 3 but with  $B/Z > 1$  and  $N = 1$ , we find no difference from the results calculated in section 3.3.

#### 4. Site investigation

##### 4.1 Preliminary Investigation

Preliminary estimations of site suitability may be made using conductivities estimated from soil texture and structure evaluated on site. Any evidence of drainage restriction within the upper 1 m should be cause to reject the site at the outset.

Hydraulic conductivities for purposes of preliminary analysis may be estimated as follows.

USDA Texture	K, m/day
Sand	5.0 — 0.5
Loamy sand to sandy loam	1.5 – 0.05
Sandy clay loam, silty clay loam, or clay loam	0.05 – 0.001
Sandy clay, silty clay or clay	0.02 – 0.0001

The higher of the values in the range are appropriate for loose or well-structured materials and the lower values for dense or poorly structured soil.

##### 4.2 Detailed investigation

The analytical methods described above may be used for final design analysis. Numerical analysis should be considered as an alternative. If this is done, it would be useful to compare the numerical results with those of the analytical methods both as a rough check on the numerical calculation and to further evaluate the utility of the analytical methods.

In any event, it is critical that soil hydraulic properties be measured as accurately as possible. In situ hydraulic conductivity tests should be run in at least 5 locations distributed over the site area. Several test depths may be necessary as indicated by the preliminary investigation. For appropriate test methods see Boersma (1965). Laboratory conductivity tests on undisturbed cores may be allowed but it is probable that the values will be lower than those in situ resulting in lower calculated permissible loading rates.



## REFERENCES

Brock, R. R. 1982. Steady state perched groundwater mounds on thick sublayers. *Water Res. Res.* 18:376—382.

Boersma, L. 1965. Field measurement of hydraulic conductivity below a water table p. 222—233. Field measurement of hydraulic conductivity above a water table. p. 234—252. In C. .. Black (ed.) *Methods of Soil Analysis*. ASA Monograph No. '9.

All, N. H. and H. T. Chan. 1982. Large sub surface sewage disposal systems. *Res. Pubi. 89.*' Ministry of the Environment Toronto, Ontario. 129 p.

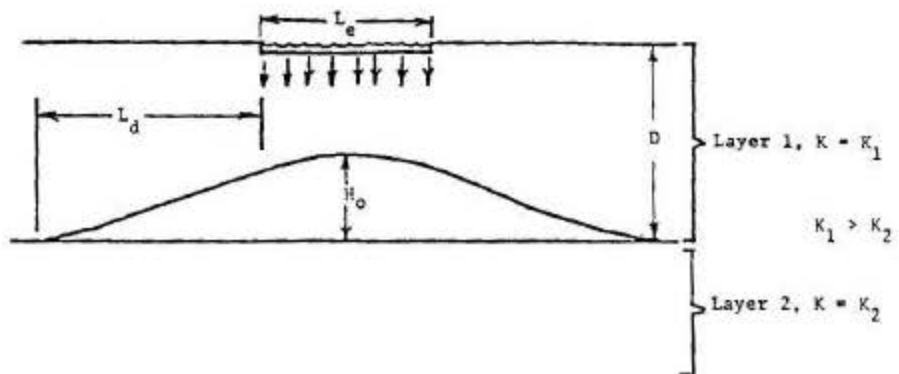

Fig. 1. Geometry of perched groundwater mound.

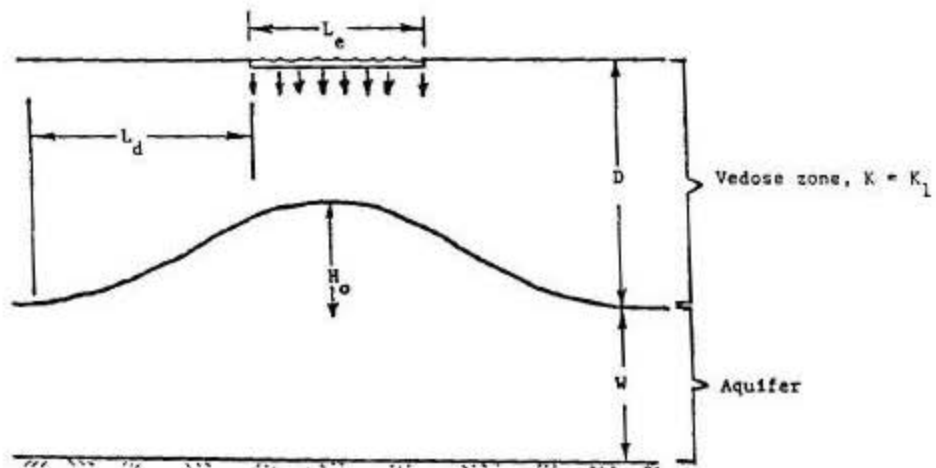

Fig. 2. Geometry of mounding above permanent water table.

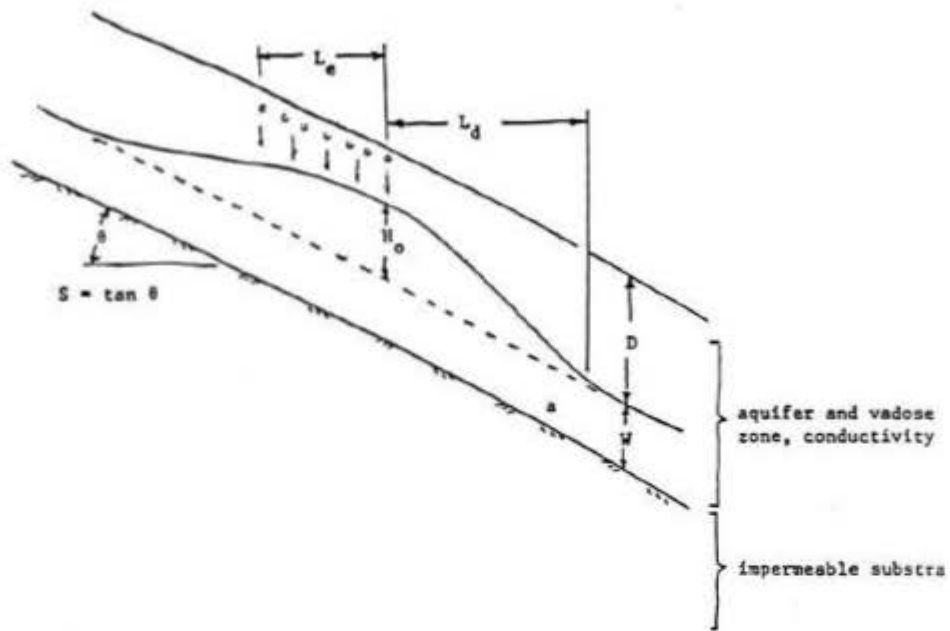

Fig. 3. Geometry of tilted aquifer.

## Predicting Water Mounds Under Subsurface

### Disposal Drainfields

P. M. Brooks, P.E.

Bureau of Wastewater Engineering

#### Introduction

When liquid is placed below the ground surface in subsurface absorption systems (SAS) it will move downward, under the influence of gravity, and horizontally under the effects of pressure (head) differences. The driving force which causes the liquid to move laterally away from the SAS can be predicted by Darcy's Law, provided several assumptions (collectively known as the Dupuit—Forcheimer assumptions) are made: (1) vertical flow below the drainfield is ignored; (2) all flow in the aquifer is horizontal and laminar; and (3) flow is uniformly distributed with depth. The head which develops between a point below the drainfield and another point some distance away on the water table supplies the driving force that moves water away from the area. The difference in heads between these two points is referred to as the "groundwater mound" (Bouwer 1978, Fielding 1977). The maximum height of the water mound is equal to maximum elevation difference between the heads.

The most critical site factors effecting head differentials (and therefore, groundwater mounding) are the various hydraulic conductivity values ("K") of the soils underlying the drainfield area, the depth of the unsaturated soils (vadose zone), and the depth of saturated soils (aquifer). The accuracy of any prediction of a groundwater mound height is directly related to the accuracy of the measurements of these parameters. Other factors effecting water mounding include slopes, trench depths, and the geometric shape of the drainfield. All these factors are addressed in the mounding equations.

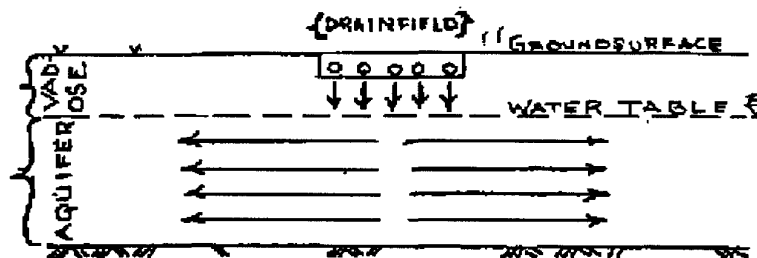

Figure 1

#### Groundwater Mound Formation

According to Darcy's Law, the velocity of the fluid mass transport within the soil is a function of both the vertical and horizontal hydraulic conductivities of the soil(s). Different conductivity values will yield different velocities and consequently, a variable mass of water will move through any given soil area over fixed time periods.

If, all other things being equal, the hydraulic conductivities of the soil(s) in the vadose zone are greater (i.e. soil is more porous) than those in the aquifer, then effluent will reach the aquifer faster than it can leave. Pressure differential will increase and the water will begin to rise (i.e. "mound") above the groundwater surface. If, all other things being

equal, the conductivities in the vadose zone are less than those in the underlying aquifer than only the upper zones need to be evaluated for mounding above the perching strata.

#### Health Implications Associated with Water Mounding Below SAS's

State Health Department concerns with water mounding beneath drainfields are threefold:

- 1) If the pressure differentials (due to differing "K" values) are large, then the mound may rise high enough to submerge the drainfield system or break out onto the ground surface; the occurrence of either one of these events being defined as system failure. Exposure of sewage on the ground surface is a health hazard.
- 2) The lateral extent of the water mound indicates the potential extent of encroachment of effluent upon surrounding features such as wells, streams, basements, roadway ditches, et cetera, and the contamination with microbiological or chemical pollutants of these features. The depth of the vadose zone and its associated horizontal conductivity values, as well as the slope and direction of any hydraulic gradients, are the major parameters effecting this phenomenon.
- 3) All the soil(s) within the water mound (as well as the aquifer) are saturated, and renovation of the wastewater is retarded. Anaerobic conditions develop under saturated soil conditions. Micro-organisms can travel longer distances and survive for longer times under these conditions and therefore, their health significance also increases.

#### Evaluation of Water Mounds

Any analysis of water movement in soils and underlying geologic materials is of necessity approximate at best, due to the complex geometry and large variability of earth materials (Parker, 1982). Several authors (Bouwer, Fielding, Brock, and Hantush) have carried out extensive analysis of groundwater mounding and computer based solutions to predict groundwater mounding exist.

However, the simplistic solutions deal with seepage beds and do not address SAS's and the computer models are too complex to serve as a useful feasibility tool. Accordingly, the Department informally requested technical assistance from VPI&SU to see if they could help provide us an evaluation of mass drainfield proposals. Dr. J. C. Parker, Assistant Professor in the Agronomy Department developed a series of equations designed to predict the phenomenon under different site and soil conditions. An empirical review by the Bureau of Wastewater Engineering of Dr. Parker's equations indicated that they predict reasonable values and, therefore, until further research indicated otherwise, Dr. Parker's equations will be utilized to evaluate water mounding potential below subsurface drainfields. A summary of Dr. Parker's work is contained in Appendix A.

#### Current Criteria for Evaluating Water Mound Potential Beneath Mass Drainfields

- 1) Separation distances from the trench bottom to the maximum mound height ( $H_0$ ) shall, as a minimum, meet the requirements of Table 12.2 of the Sewage Handling and Disposal Regulations. An unsaturated zone of at least 3 to 6 feet below the drainfield is desirable.

- 2) The allowable lateral extent ( $L_d$ ) of the water mound shall be evaluated using the requirements of Table 12.1 "Minimum Separation Distances" of the Regulations.
- 3) Prior to final approval of mass drainfield values for hydraulic conductivities should be either measured in situ or in the laboratory by a person qualified to perform these tests. Values should be determined for each soil horizon below the proposed trench bottom down into the unconfined aquifer, bedrock or sea level.
- 4) The "effective" depth ( $W$ ) of the unconfined aquifer shall be considered to equal the effective width ( $L_c$ ) of the drainfield.
- 5) The vadose zone ( $D$ ) shall be considered to equal the depth from the ground surface to either the seasonal water table as indicated by grey mottles (chroma 2 or less on the Munsell Chart) or free water is reached.

#### Design Analysis

If preliminary analyses show promise, more detailed site Investigations should be undertaken to proceed with system design.

##### A. Fixed parameters

Values of minimum depth of vadose zone ( $D_{Min}$ ), and maximum allowable lateral extent of water mound, slopes, aquifer depths,

##### B. Site parameters

The site investigation should involve augering a sufficient number of holes uniformly dispersed over the proposed SAS site to a depth of 30 ft. or to a layer of high hydraulic resistance (e.g. rock or dense clay) or to sea level, whichever is less. A visual description of the texture, structure and consistence of the material should be made by a qualified soil scientist, engineer or sanitarian. Measurements of hydraulic conductivity should be made in each textural layer below the depth  $D_{min}$  or at depths no further apart than 3 ft., for holes of 10 ft depth or less and 6 ft. apart, for holes deeper than 10 ft. Measurements may be made in situ using any accepted methods (see references) or In the laboratory on core samples taken with a sampler having a wall thickness to sample diameter ratio of no greater than 0.07. Conductivity values for each depth used In calculations of  $L_c$  shall be the arithmetic mean of the individual values for that depth. (Parker, 1982)

The average minimum water table depth will be taken as  $D_{min}$  (equal to the depth to the grey mottles). From the absolute water table elevations, both water table slope and flow hydraulic gradients will be estimated.

##### C. Calculations

Calculations are performed using the same equations developed by Dr. Parker. The permit applicant should have the option of using more sophisticated numerical models if he chooses; however, these results should be evaluated on a site-by-site basis and should include a comparison with the method employed in these recommendations.

## References for Saturated Hydraulic Conductivity Measurements

### In situ:

Boersma, L. 1965. Field measurement of hydraulic conductivity below a water table. In C. A. Black (ed.) Methods of Soil Analysis. ASA No. 9 2:222-233.

Boersma, I. 1965. Field measurement of hydraulic conductivity above a water table. In C. A. Black (ed.) Methods of Soil Analysis. ASA No. 9. 1:234-252.

### Laboratory:

Klute, A. 1965. Laboratory measurement of hydraulic conductivity of saturated soil. In C. A. Black (ed.) Methods of Soil Analysis. ASA No. 9 1:210-221.

## References

Bouwer, H. 1978 Groundwater Hydrology (Chp. 2 & 3) McGraw-Hill Book Co. New York, N.Y.

Hantush, M.S. 1967 "Growth and Decay of Groundwater Mounds in Response to Uniform Percolation." Water Resources Research, Vol. 3, No. 1 (referenced in Bouwer).

Fielding, M.B. "Groundwater Mounding Under Leaching Beds."

Parker, J.C. 1982 "Analysis of Water Table Mounding and Recommendations for Mass Drainfield Design" unpublished correspondence.

## Appendix A

Predicting water table mounding (after Dr. J. C. Parker's November 22, 1982 report "Analysis of Water Table Mounding and Recommendations for Mass Drainfield Design").

Dr. Parker developed a series of equations to predict water mounding under various site conditions (Figures 2, 3, 4 and 5). These equations are summarized on page A-2; identification of the terms in these equations follows:

<u>Term</u>	<u>Definition</u>
$H_0$	Maximum height of water mound, ft (m).
$a$	Ratio of drainfield length to drainfield width, $L_f/L_c$ .
$J$	Total volume of effluent applied to the drainfield per unit time, $\text{ft}^3/\text{day}$ ( $\text{m}^3/\text{d}$ )
$K_1$	Hydraulic conductivity in vadose zone, ft/d (m/d).
$K_2$	Hydraulic conductivity in aquifer, ft/d (m/d).
	Note: $K_1 = K_2 > 10$ and $q/K_1 < 0.2$ (where $q$ = volume per unit time per unit area) for equation 1 to be valid.
	Weighted mean conductivities $K(Z) = \frac{\sum L_i}{\sum L_i/K_i}$
	Where $K_i$ = conductivity of layer $i$ .
	Where $L_i$ = thickness of layer $i$ .
$L_c$	Width of drainfield, ft.(m)
$L_c$	Total effective width of drainfield area, ft (m).
$L_f$	Length of drainfield, ft. (m)
$L_f$	Total effective length of drainfield area, ft (m).
$L_d$	Lateral extent of water mound from edge of drainfield, ft (m).
$W$	Aquifer thickness, ft (m).
$B$	Difference in elevation between the local topographic high and average drainfield elevation, ft (m).
$Z$	Average soil depth to an impermeable lower boundry, ft (m).
$N$	Correction factor, equals 1 for $(B/Z \geq 1)$ or $N=2 - B/Z$ for $(B/Z < 1)$



Appendix A continued

D	Depth of vadose zones ft (m).
S	Fractional slope.
F	Depth of percolation line
$\Theta$	Angle of effluent spreading (typically 30°)

Equations

$$\text{Equation 1} \quad H_0 = \frac{(1 + a^2)^{1/2}}{2a^2} \left[ \frac{J^2}{K_1 K_2 L_c^2} - \frac{aJ}{K_1} \right]^{1/2}$$

$$\text{Equation 2} \quad L_d = J/aL_cK_2 - L_c/2$$

$$\text{Equation 3} \quad H_0 = \frac{(1 + a^2)^{1/2}}{2a^2K_1} \left[ \frac{J^2L_d}{H_0L_c^2} + \frac{J^2}{2H_0L_c} - aJK_1 \right]^{1/2}$$

$$\text{Equation 4} \quad L_d = L_c/4W - L_c/2 = \frac{L_c^2}{4W} - \frac{L_c}{2}$$

$$\text{Equation 5} \quad L_c = \frac{2JL_d(1 + a^2)^{1/2}}{A^2K_1N} \left[ H_0^2 + H_0(2W + L_dS) + 2L_dWS \right]^{-1}$$

$$\text{Equation 6} \quad L_d = L_c/2NW - L_c/2 = \frac{L_c^2}{2WN} - \frac{L_c}{2}$$

$$\text{Equation A} \quad L_c = L'_c + 2(D - F - \frac{H_0}{2}) \tan \theta$$

$$\text{Equation B} \quad L_f' = \frac{x-c}{1-c} ; [C = [1 + \frac{L_c'}{2}(D - F - \frac{H_0}{2} \tan \theta)]^{-1}$$

MOUND = EQUATION 1  
MOUND 3 = EQUATION 3

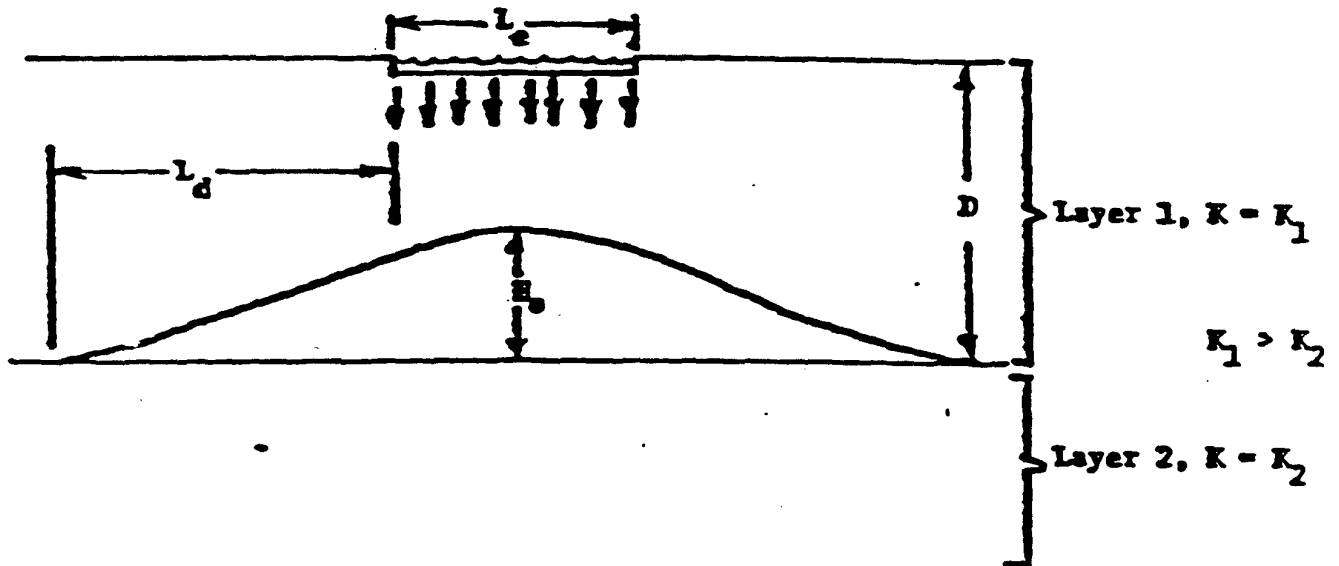
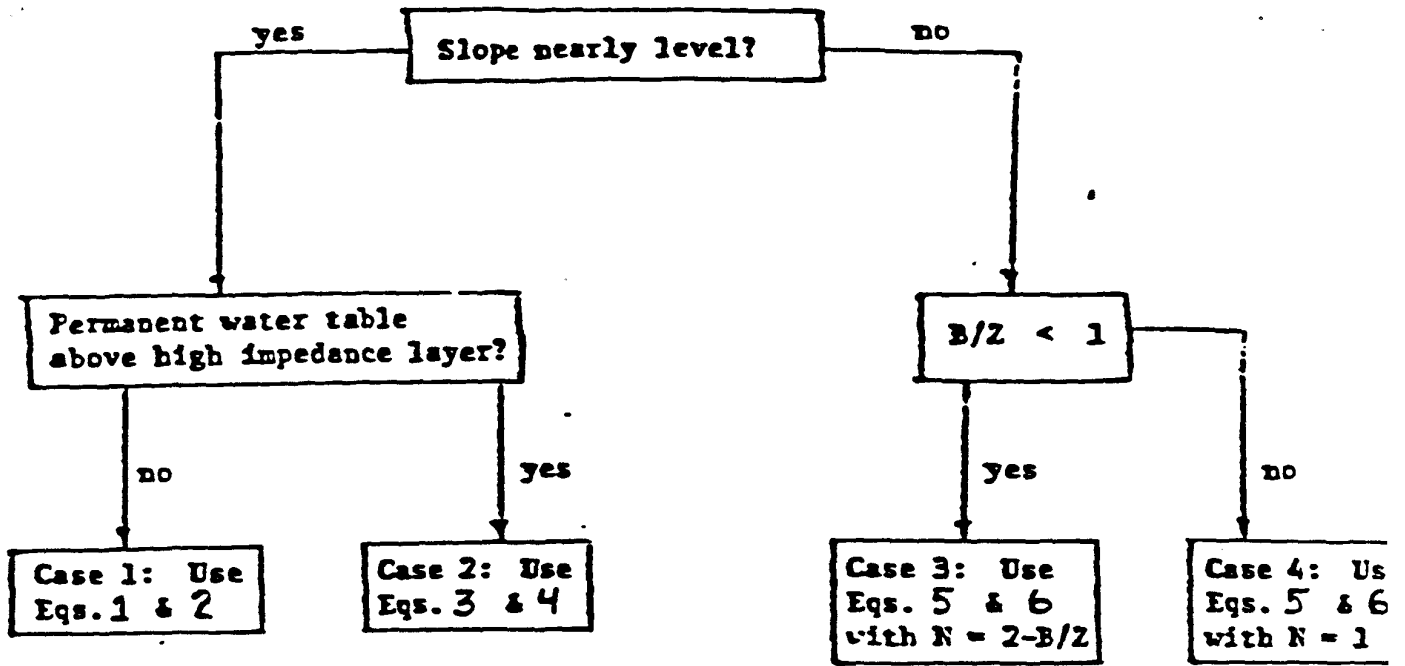

Fig. 3 Geometry of perched groundwater mound.

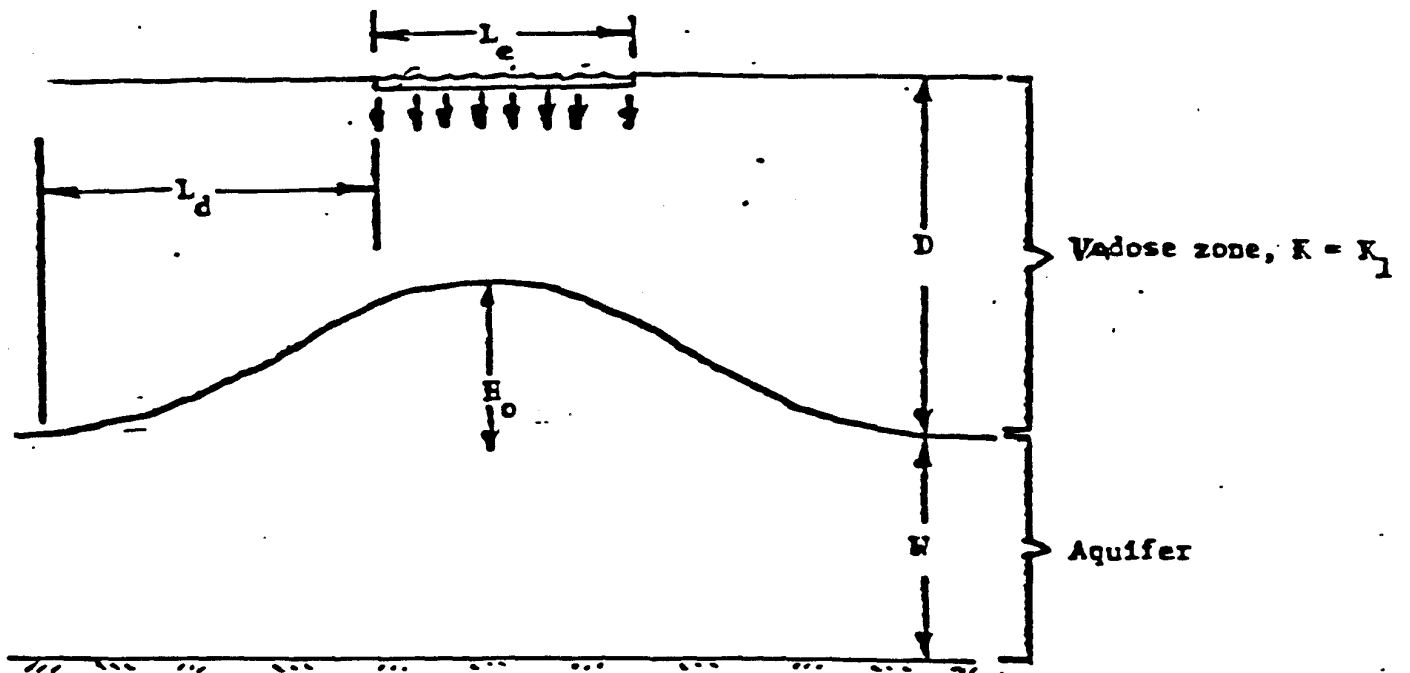
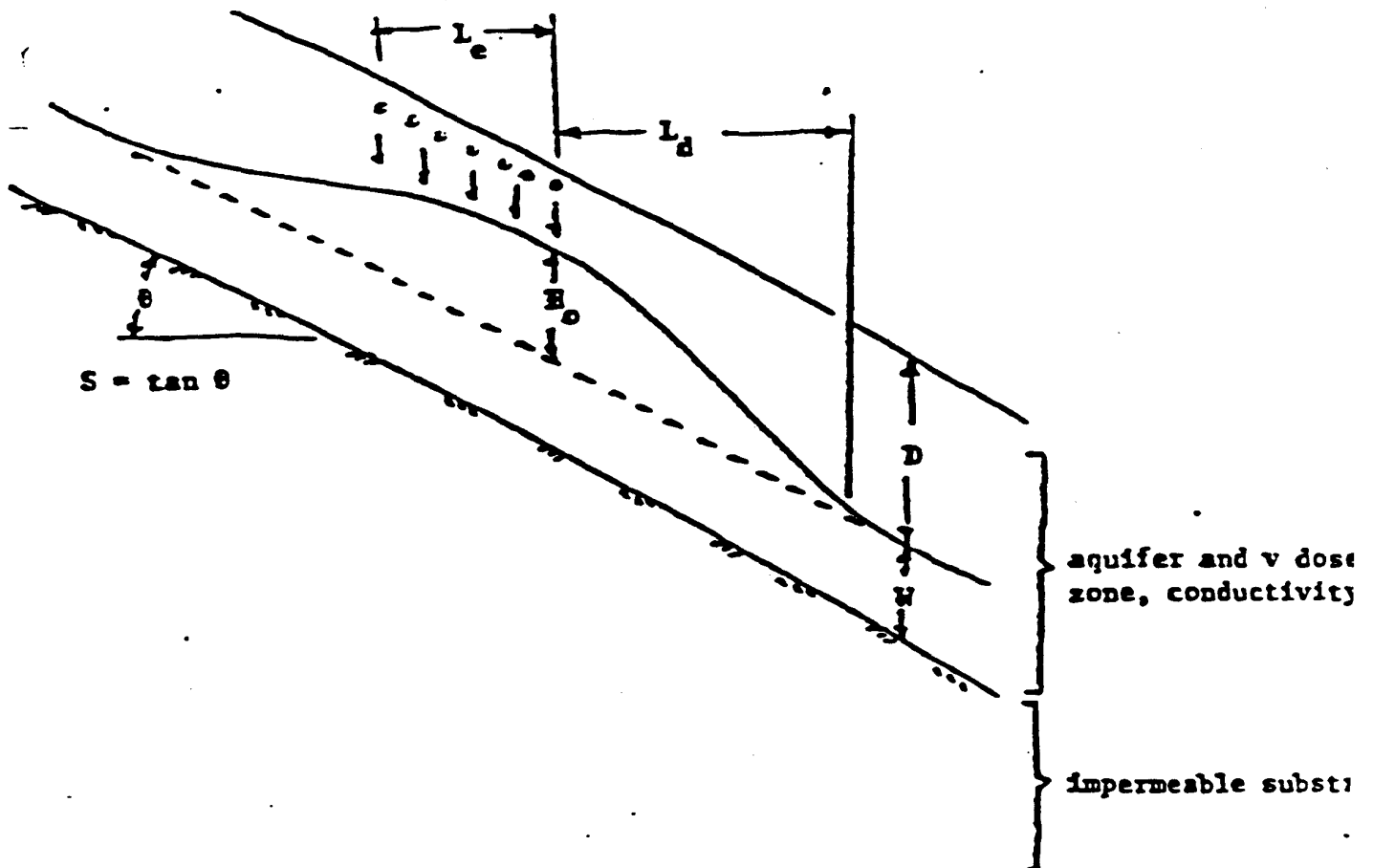

Fig. 4 Geometry of mounding above permanent water table.



# APPENDIX B

## Predicting Water Mounds - Example Problems <sup>1</sup>

### Case I

Flow = 5,500 GPD

Sandy Loam from 0-45"; Sandy Clay from 45" to bedrock at 110". There is a fragipan at 45" and a seasonal water table also exists at the pan. The estimated percolation  $n$  for the Sandy loam is 30 mm/INCH.

The following disposal scheme is proposed. Evaluate the potential for mounding:

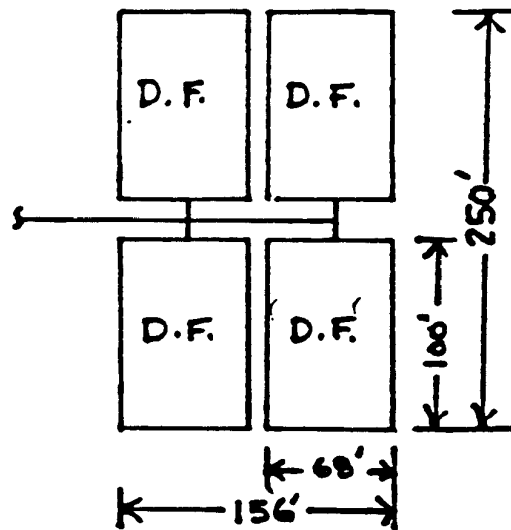

PLAN VIEW

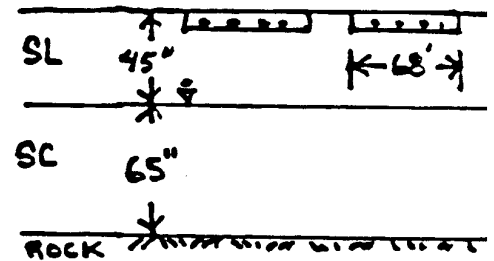

PROFILE

Each drainfield (D.F.) has twelve 2.0<sup>FT</sup> x 100.0<sup>FT</sup> TRENCHES. Enhanced flow distribution will be used & a reserve area is available.

1. Refer to Fig. 2, pg A-4 for case conditions

A) Evaluate an individual D.F. using Equations 1 & 2 or page A-3.

PARAMETERS REQUIRED

$$L_c = [2 \text{ FT} \times 3 \times (12-3)] + 2 \text{ FT} = 68 \text{ FT}$$

$$L_f = 100 \text{ FT}$$

$$a = \frac{100}{68} = 1.47$$

$$Q = J = \frac{5,500 \text{ GAL/DAY}}{4 \text{ D.F.}} \times .13368 \frac{\text{FT}^3}{\text{GAL}} = 184 \frac{\text{FT}^3}{\text{DAY-D.F.}}$$

$$\left. \begin{array}{l} K_1 = 5 \frac{\text{FT}}{\text{DAY}} \\ K_2 = .02 \frac{\text{FT}}{\text{DAY}} \end{array} \right\} \text{THESE VALUES MAY REQUIRE FIELD VERIFICATION}$$

SOLVE FOR MOUND HEIGHT,  $H_o$

$$H_o = \frac{(1+a^2)^{1/2}}{2a^2} \times \left[ \frac{J^2}{K_1 K_2 L_c^2} + \frac{aJ}{K_1} \right]^{1/2} \quad \text{Equation}$$

Substitute in parameters

$$H_o = \frac{(1+1.47^2)^{1/2}}{(2)(1.47^2)} \times \left[ \frac{184^2}{(5)(.02)(68^2)} - \frac{(1.47)(184)}{5} \right]$$

$$= \frac{(3.16)^{1/2}}{(4.32)} \times \left[ \frac{33,856}{462.4} - \frac{270.48}{5} \right]^{1/2}$$

SEE NOTE 2

$$= (0.41 \times 4.37)$$

$$\boxed{H_o = 1.74 \text{ FT}}$$

## Solve for Length of Mound

$$L_d = \frac{J}{a L_c K_2} - \frac{L_c}{2} \quad \text{Equation 2}$$

$$= \frac{184}{(1.47)(68)(.02)} - \frac{68}{2}$$

$$\boxed{L_d = 58 \text{ FT}}$$

B.) Evaluate Entire Site & Determine Which Drainage Configuration is most critical

parameters required

$$L_c = 156 \text{ FT}$$

$$L_f = 250 \text{ FT}$$

$$a = \frac{250}{156} = 1.60$$

$$J = 5,500 \text{ gpd} \times 0.13368 = 735.2 \frac{\text{FT}^3}{\text{day}}$$

$$K_1 = 5 \frac{\text{FT}}{\text{day}}$$

$$K_2 = 0.03 \frac{\text{FT}}{\text{day}}$$

} May require field verification

---

NOTE 2. The symbol " $( )^{1/2}$ " is equal to the symbol " $\sqrt{\quad}$ ", i.e. take the square root.

Solve for  $H_0$

$$H_0 = \frac{(1 + a^2)^{1/2}}{2a^2} \left[ \frac{J^2}{K_1 K_2 L_c^2} - \frac{aJ}{K_1} \right]^{1/2}$$

Substitute and solve

$$H_0 = \frac{(1 + 1.6^2)^{1/2}}{(2 \times 1.6)^2} \times \left[ \frac{735.2^2}{(5 \times 0.03 \times 156^2)} - \frac{(1.6 \times 735.2)}{5} \right]$$

$$= 0.36 \times \sqrt{-87.2}$$

A negative number indicates  
no mound formation. Equations  
can not predict decreased.

$$\boxed{H_0 = \text{ZERO}}$$

CHECK ASSUMPTIONS  $L_c' = L_c$  &  $L_b' = L_b$

SEE NOTE 3

USE EQUATION A TO EVALUATE  $L_c$

parameter required

$$D = 45'' = 3.75 \text{ FT}$$

$$F \leq D - H_0 \leq (3.75 - 1.74) \leq 2.01 \text{ SAY } 2 \text{ FT}$$

$$\theta = 30^\circ$$

$$L_c = L_c' + 2 \left( D - F - \frac{H_0}{2} \right) \tan \theta$$

Substitute:

$$L_c = 68 + 2 \left( 3.75 - 2 - \frac{1.74}{2} \right) \tan 30^\circ$$

$$= 68 + 2(0.88) \tan 30^\circ$$

$$= 68 + 2(0.88 \times 0.577)$$

$$= 68 + 1.016$$

$$\boxed{L_c = 69.02 \text{ FT}}$$



$L_c'$  is within 2% of  $L_c$  and the assumption was valid.

$$L_f' = \frac{a-c}{1-c} \quad \& \quad c = \left[ 1 + \frac{L_c'}{2} \left( D-F - \frac{H_0}{2} \tan \theta \right) \right]^{-1}$$

Solve for 'c'

$$c = \frac{1}{1 + \frac{L_c'}{2} \left( D-F - \frac{H_0}{2} \tan \theta \right)}$$

Substituting

$$c = \frac{1}{1 + \frac{68}{2} \left( 3.75 - 2 - \frac{1.74}{2} \tan 30^\circ \right)}$$

$$= 0.054$$

Solve for  $L_f'$

$$L_f' = \frac{1.47 - 0.054}{1 - 0.054} = 1.498$$

Solve for  $L_f$

$$L_f = (L_c' \times L_f') = (68)(1.498) = \underline{\underline{99.82 \text{ FT}}}$$

### C.) CONCLUSION

FIGURE 1.

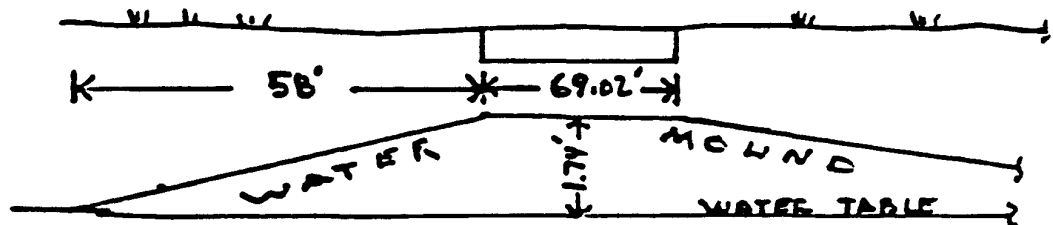

NOT TO SCALE

NOTE 3. The initial assumption was that the effective width,  $l_c =$  the actual width,  $L_c'$ . We must check this assumption to make sure  $l_c$  is not greatly larger than  $L_c'$ . Also check  $L_f$  &  $L_f'$  are within reason.

TRENCH DEPTHS MUST NOT EXCEED ~~12.3~~ 24" (3.75'-1.74') if the water mound is not to encroach upon the percolation lines. Any wells, lakes, streams, roadway ditches, etc. should be at least 50 FT away from any adsorption trench.

## CASE II

Flow = 7,200 GPD

Tight, Sandy clay loam from ZERO TO 35 FEET, Water table at 12.3 FEET, ESTIMATED percolation rate is 45 mm/INCH.

The following <sup>-ing</sup> low pressure distribution scheme is proposed.

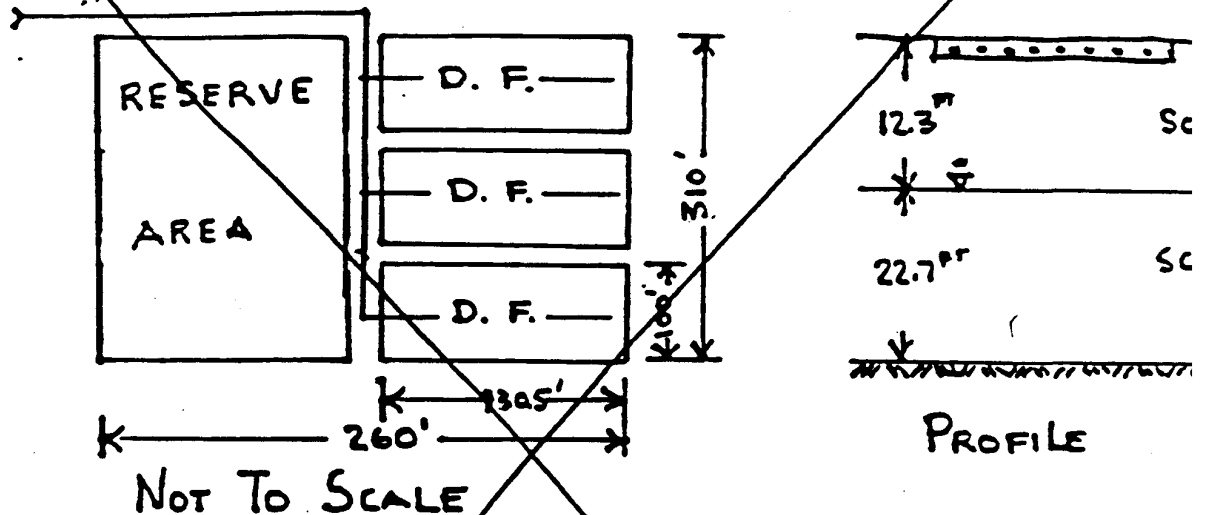

EACH D. F. CONSISTS OF TWENTY ~~2.25~~ <sup>2.25 FT</sup> ~~2.25~~ <sup>2.25 FT</sup> X 100.0 FT TRENCHES. THE RESERVE AREA IS NOT SHOWN FOR CLARITY. EVALUATE THE ENTIRE SYSTEM FOR WATER MOUNDING POTENTIAL.

A.) EVALUATE system using Equations 3 & 4 on page A-3

### Parameters Required

$$L_c = [2.25^{FT} \times 3 \times (20-1)] + 2.25^{FT} = 130.5^{FT}$$

$$L_s = 100.0^{FT}$$

## Case II

Given the following information, evaluate the potential for water mounding below the drainfield.

### REPRESENTATIVE SOIL PROFILE

Applying Series			PERC. RATE	CONDUCTIVITY VALUE (Appendix C)
A <sub>p</sub>	0-6"	(2.5 YR 4/2) sL		
B <sub>1</sub>	6-15	(7.5 YR 5/6) sCL	45 $\frac{MLD}{W}$	FT/day
B <sub>2</sub>	15-24	(5 YR 5/6) cL	50	6
B <sub>22</sub>	24-35	(5 YR 5/6) cL with (2.5 YR 4/8) and (7.5 YR 5/6) streaks	50	2
B <sub>3</sub>	35-50	(5 YR 4/6) cL with (7.5 YR 5/6) and (7.5 YR 7/8) mottles	60	1
C	50-110	(5 YR 4/6) sCL with (10 YR 5/4) and (7.5 YR 5/6) mottles.	45	10

Applicant proposed to dispose of 7,200 gpd of sewage utilizing low pressure distribution.

Each drainfield system consists of 40, 2.25 FT x 50.0 FT lines with the manifold running down the center of the drainfield.

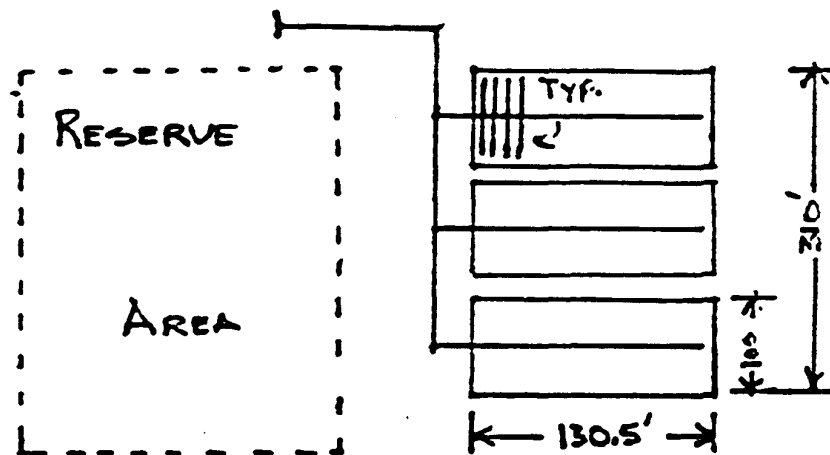

SITE PLAN  
(not to scale)

a) Determine avc. k value

$$K(z) = \frac{\sum L_i}{\sum \frac{L_i}{K_i}}^*$$

parameters needed  
(trench will be at 18")

$$L_{B2} \left( \frac{24-15}{12} \right) = .75^{\text{ft}} \quad K=6$$

$$L_{E22} \left( \frac{35-24}{12} \right) = .91 \quad K=2$$

$$L_{E3} \left( \frac{35-50}{12} \right) = 1.25 \quad K=1$$

$$L_C \left( \frac{110-50}{12} \right) = 5.0 \quad K=10$$

$$\sum L_i = 7.91^{\text{ft}}$$

$$K(z) = \frac{7.91}{\left( \frac{.75}{6} \right) + \left( \frac{.91}{2} \right) + \left( \frac{1.25}{1} \right) + \left( \frac{5}{10} \right)} = 3$$

b) Determine Length ( $L_d$ ) of water mound

$$L_d = \left( \frac{L_c^2}{4W} - \frac{L_c}{2} \right)$$

parameters needed

$$L_c = 130.5^{\text{ft}}$$

$$W = \left( \frac{110 - 35}{12} \right) = 6.25^{\text{ft}}$$

$$L_d = \left( \frac{130.5^2}{4 \times 6.25} - \frac{130.5}{2} \right)$$

Equation  
4

$$= \frac{17,030.3}{25} - 65.3$$

$$\boxed{L_d = 644.3^{\text{ft}}}$$

6/16

---

\* See Appendix A, pg A-1. "Σ" means "ADD UP."

c) Solve for Mound Height ( $H_0$ )

$$H_0 = \frac{(1+a)^{1/2}}{2a^2K} \left[ \frac{J^2 L_d}{H_0 L_c^2} + \frac{J^2}{2H_0 L_c} - aJK \right]^{1/2} \quad \text{Eq. 1}$$

parameters needed

$$L_c = 130.5 \text{ FT}$$

$$L_f = 310.0 \text{ FT}$$

$$a = \frac{310}{130.5} = 2.37$$

$$J = Q = 7200 \text{ Gpd} \times 0.13368 \frac{\text{FT}^3}{\text{GAL}} = 962.5 \frac{\text{FT}^3}{\text{day}}$$

$$K = 3.39 \frac{\text{FT}}{\text{day}}$$

$$L_d = 644.3 \text{ FT}$$

Substituting into Equation 3

$$H_0 = \frac{(1+2.37^2)^{1/2}}{2 \times 2.37^2 \times 3.39} \times \left[ \frac{962.5^2 \times 644.3}{H_0 \times 130.5^2} + \frac{962.5^2}{2 \times H_0 \times 130.5} - 2.37 \times 962.5 \times 3.39 \right]^{1/2}$$

$5.7066625 \times 10^8$

$$H_0 = \frac{\sqrt{6.61}}{38.08} \times \sqrt{\frac{596,883,546.8}{17,030.3 H_0} + \frac{926,406.3}{261 H_0} - 7,687.4}$$

$$= 0.067 \times \sqrt{\frac{33,508.9}{H_0} + \frac{3,549.4}{H_0} - 7,687.4}$$

Square all terms

$$H_0^2 = .067^2 \left( \frac{37,058.3}{H_0} - 7,687.4 \right)$$

$$H_0^2 = \frac{173.27}{H_0} - 34.50$$

$166.35$   
 $34.51$

Set equation equal to zero

$$\left( H_0^2 - \frac{173.27}{H_0} + 34.5 \right) = 0$$

Solve using a trial & error method

$H_0$	solved equation equals	Actual $H_0$
5.0	$5^2 - \frac{173.27}{5} + 34.5 = 24.85$	too large
4.0	$4^2 - \frac{ETL}{4} + \text{ditto} = 7.19$	too large
3.0	$3^2 - \frac{ETL}{3} + \text{ditto} = -14.25$	too small
3.5	$3.5^2 - \frac{ETL}{3.5} + \text{ditto} = -2.75$	too small
3.7	$3.7^2 - \frac{ETL}{3.7} + \text{ditto} = 1.36$	too large
3.6	$3.6^2 - \text{"} + \text{"} = -.66$	too <sup>small</sup> large
3.65	$3.65^2 - \text{"} + \text{"} = .36$	too large.
3.63	$3.63^2 - \text{"} + \text{"} = -.047$	OK

$$H_0 = 3.63 \text{ FT}$$

$$H_0 = 3.4'$$

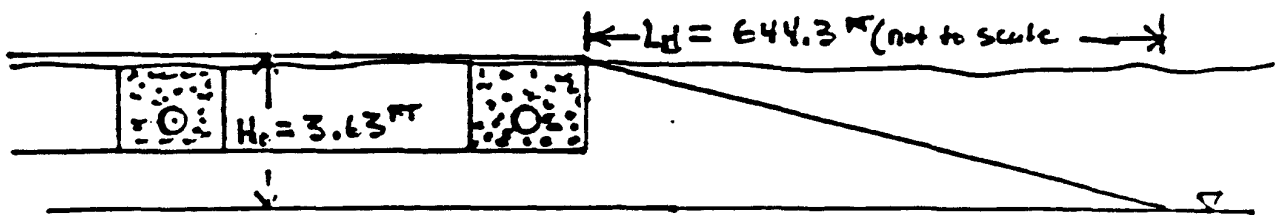

AQUIFER AT 35" to 110"

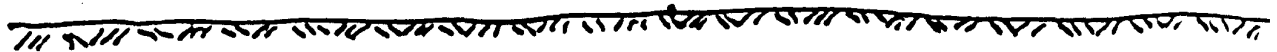

SCALE VERTICAL 1" = 4.0'  
 HORIZONTAL NO SCALE

## SUMMARY

Because the depth of the vadose zone (35' is less than the mound height (43.56"), the proposed system ~~will~~ will fail and the project is denied

---

Appendix C

ESTIMATED HYDRAULIC CHARACTERISTICS OF SOIL<sup>1</sup>

<u>Soil Texture</u>	<u>Permeability</u> ft/day	<u>Percolation</u> min/in.
Sand	>12.0	<10
Sandy loams Porous silt loams Silty clay loams	0.4-12.0	10-45
Clays, compact	<.4	>45

<sup>1</sup>From "DESIGN MANUAL ONSITE WASTEWATER TREATMENT AND DISPOSAL SYSTEMS  
(October 1980)

U.S. ENVIRONMENTAL PROTECTION AGENCY, Office of Water Program Operations,  
Office of Research and Development, Municipal Environmental Research  
Laboratory